

Efka dc modular

CONTROL

AB70B4012

INSTRUCTION MANUAL

No. 206602 english

Contents

| | | |
|-----------|---|-----------|
| 1. | Safety instructions | 2 |
| 2. | Some preliminary remarks | 4 |
| 3. | Putting into operation and handling | 6 |
| 3.1 | Opening of technician level | 6 |
| 3.2 | Adjustment of sense of rotation of the motor | 7 |
| 3.3 | Adjustment and storage of positions | 8 |
| 3.3.1 | Basic position | 8 |
| 3.3.2 | Needle positions | 10 |
| 3.3.2.1 | Correction of needle positions | 12 |
| 3.4 | Addressing and programming of parameters (TECHNICIAN LEVEL) | 13 |
| 3.5 | (Dis)connection of basic functions (OPERATOR LEVEL) | 16 |
| 3.6 | Performance of reset | 18 |
| 4. | Parameter list | 20 |
| 4.1 | Some advices | 20 |
| 4.2 | Fault indications | 21 |
| 4.3 | Parameters of technician level | 22 |
| 4.4 | Diagrams of signals | 29 |
| 5. | Connections to the sockets | 35 |
| 6. | Connection scheme of the sockets | 36 |

1. Safety instructions

1. Motor, accessories and auxiliary devices can be mounted and put into operation only by an expert after taking note of the instruction manual.
2. Motor, accessories and auxiliary devices must be used only in conformity with their designed function.
3. Operation without corresponding protective devices is forbidden.
4. Motor must be completely mounted before electric connection.
5. Only skilled labour is allowed to work on the electric appliances.
6. Only especially trained staff is allowed to complete repair work.
7. Cables to be wired must be protected against expectable strain and fastened adequately.
8. Cables near moving machine parts (e.g. pulleys) must be wired at a minimum distance of 25 mm. (see DIN VDE 0113)
9. For a safe separation it is preferred to wire the cables separately from each other. (see DIN VDE 0160, § 5.6.3)
10. Connect the sewing light to the mains independently of the motor power supply.
11. Before connecting the mains line make sure that the mains voltage corresponds to the specifications on the control nameplate.
12. Machine and motor must be connected through a potential equalization conductor.

13. Before mounting and adjusting auxiliary devices and accessories, especially position transmitter, reversing device, light barrier, etc., disconnect the motor (disconnect the main switch, pull off mains plug, see DIN VDE 0113).
14. Electric auxiliary devices and accessories must only be connected to protective low voltage.
15. Disconnect the motor for any repair and maintenance work. (disconnect the main switch, pull off mains plug, see DIN VDE 0113).
16. The motor resists overvoltage according to overvoltage class 2 - DIN VDE 0160
17. Working on parts and devices under voltage is forbidden.
- Exceptions to prescriptions DIN VDE 0105
18. Observe all safety instructions before undertaking conversions and modifications.
19. Use for repair and maintenance only original parts from the manufacturer.
20. Warning indications in the instruction manual point out particular risks of personal injury or risk for the machine and are characterized by the below-mentioned symbol at the concerned place.
Observe and follow these indications as well as the prevailing safety instructions!



2. Some preliminary remarks

The control's field application comprises the following machines:

Ferrari knitting machines

The control is provided with a keyboard accessible from outside which serves for the programming of the control and for the selection of the desired machine functions; the input connection states and values are stored in the control.

The access to functions and parameters is divided between two levels:

OPERATOR LEVEL

On this level some basic functions can be (dis)connected which are frequently required by the machine user for the sewing operations and must therefore be easily changeable.

TECHNICIAN LEVEL

On this level all parameters which are not submit to frequent changes can be adjusted. These parameters are stated in the later following parameter list. In addition, also the basic functions of the OPERATOR LEVEL can be addressed and (dis)connected on this level.

IMPORTANT! Both the (dis)connection of the basic functions and the addressing and programming of the parameters are, as a matter of principle, only possible immediately after the machine has been switched on or after a preceding trimming operation.

The connection states and settings are transferred into the memory of the control after terminated adjustment operation by short start of sewing. The machine may only be switched off afterwards as otherwise the previously set values will get lost (exception: reset).

After having been mounted on the machine and after adjustment of its sense of rotation and of the positions, the motor is immediately ready for operation since the machine specific parameters have already been programmed according to the instructions of the machine manufacturer resp. the supplier.

3. Putting into operation and handling

3.1 Opening of technician level

In order to be able to address and program the parameters of the **TECHNICIAN LEVEL**, this must be opened:

- (1) Press pushbutton P and switch on the machine while keeping pushbutton depressed.

- display indicates blinking:

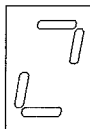

- (2) With pushbutton E the parameters available according to the parameter list can now successively be recalled. For this purpose the pushbutton must repeatedly be pressed until the abbreviation of the desired parameter appears on the display (= operating step (1) in chapters 3.2, 3.3.1, 3.3.2 and 3.4).

The opened **TECHNICIAN LEVEL** respectively remains accessible until the machine is switched off. After a sewing operation the pedal just has to be shortly heeled completely back and then pushbutton P depressed. On the display above symbol reappears. After pressing of pushbutton E the display indicates the abbreviation of the parameter addressed at last, the connection state or input value of which now being correctable, if required.

3.2 Adjustment of sense of rotation of the motor

The required sense of rotation of the motor has to be adjusted before the needle positions (chapter 3.3.2), since these must be readjusted on every reversion of the sense of rotation.

- (1) Address parameter "sense of rotation of the motor" with pushbutton E.

- display indicates:

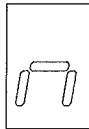

- (2) Press pushbutton +.

- display indicates:

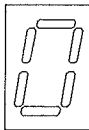

(= clockwise rotation)

or

- display indicates:

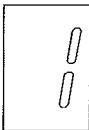

(= anti-clockwise rotation)

- (3) Change the connection state, if required, with pushbutton + or -.

3.3 Adjustment and storage of positions

The positions of the machine are registered by the position transmitter in steps (increments) of approx. $0,7^\circ$. One revolution of the handwheel is thus subdivided into 512 increments.

The counting starts from a basic position to be input which may e. g. be the position where the needle point is at the height of the needle plate (this basic position is freely determinable).

Once input, the needle positions will also remain stored if the position transmitter is exchanged; merely the basic position will have to be input anew.

3.3.1 Basic position

- (1) Address parameter "basic position" with pushbutton E.

- display indicates:

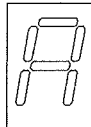

- (2) Press pushbutton +.

- display indicates blinking:

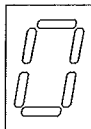

- (3) Turn handwheel until the indication on the display stops blinking, then position handwheel in a way that the needle point will be at the height of the needle plate (or in another desired position).

Now, the adjustment operation can either be terminated with operating step (4) or - if, besides the basic position, also the needle positions shall be adjusted - be continued with operating step (2) in chapter 3.3.2.

- (4) Press pushbutton P.
 - indication on the display disappears
 - adjustment operation is terminated

3.3.2 Needle positions

- (1) Address parameter "lower needle position" with pushbutton E.

- display indicates:

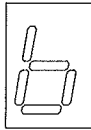

- (2) Press pushbutton +.

- display indicates blinking:

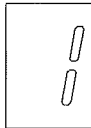

- (3) Turn handwheel until the indication on the display stops blinking, then adjust lower needle position.

- (4) Address parameter "upper needle position" with pushbutton E.

- display indicates:

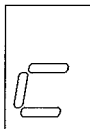

- (5) Press pushbutton +.

- display indicates blinking:

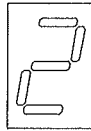

- (6) Turn handwheel until the indication on the display stops blinking, then adjust upper needle position.

- (7) Address parameter "adjustment of connection point for signal FA2" (see chapter 4.4.1) with pushbutton E.

- display indicates:

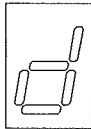

- (8) Press pushbutton +.

- display indicates blinking:

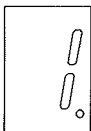

- (9) Turn handwheel until the indication on the display stops blinking, then adjust connection point for signal FA2.

- (10) Press pushbutton P.

- indication on the display disappears
 - adjustment operation is terminated

In case of any inaccuracies of positioning these will be recognized by the control during the first test run and will then automatically be corrected.

3.3.2.1 Correction of needle positions

If a needle position is to be corrected, the adjustment operation will have to be repeated.

Thereby, those positions which need not be modified can be skipped by repeatedly pressing pushbutton E until the abbreviation of the desired parameter appears on the display.

The position to be corrected can then be readjusted according to the preceding description.

3.4 Addressing and programming of parameters **(TECHNICIAN LEVEL)**

As an example for all other parameters the addressing and programming of parameters "maximum speed" and "softstart stitches" are described hereafter.

- (1) Address parameter "maximum speed" with pushbutton E.

- display indicates:

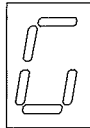

- (2) Press pushbutton +.

- display indicates e. g.:

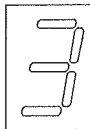

(= the earlier set speed value lies between 3000 and 3400 RPM, indicated by the figure)

or

- display indicates e. g.:

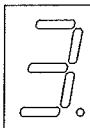

(= the earlier set speed value lies between 3500 and 3900 RPM, indicated by the figure with point)

- (3) Increase or decrease maximum speed with pushbutton + or -, e. g. as follows:

desired speed of rotation = 5600 RPM

set speed of rotation = 3400 RPM

- display indicates:

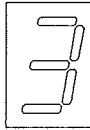

Keep pushbutton + depressed until

- display indicates:

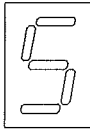

(= 5000 RPM)

Repeatedly press pushbutton + shortly until

- display indicates:

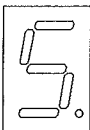

(= 5500 RPM)

Press pushbutton + once again shortly

(= 5600 RPM).

The speed value is, in this example, changed in steps of 100 RPM, i. e. every short pressing of pushbutton + or - increases or decreases the value by 100 RPM, whereas sustained pressing of a pushbutton continuously changes the value by a multiple of 100 RPM (step sizes of other parameters: see parameter list).

- (4) Address parameter "softstart stitches" with pushbutton E.

- display indicates:

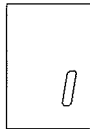

- (5) Press pushbutton +.

- display indicates e. g.:

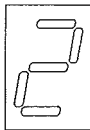

(= earlier set stitch number)

- (6) Increase or decrease stitch number with pushbutton + or -.

Further parameters can analogously be addressed and programmed.

- (7) Press pushbutton P.

- indication on the display disappears
- adjustment operation is terminated

3.5 (Dis)connection of basic functions **(OPERATOR LEVEL)**

With pushbutton E, + and - the following functions can be (dis)connected:

Pushbutton E - SOFTSTART

OFF (LED is not illuminated)
ON (LED is illuminated)

Pushbutton + - THREAD TRIMMER (and THREAD WIPER)

OFF (LED is not illuminated)
ON (LED is illuminated)

Pushbutton - - NEEDLE POSITION AT STOP BEFORE TRIMMING

DOWN (LED is not illuminated)
UP (LED is illuminated)

In addition, the adjusted maximum speed (see chapter 4.3) can be reduced down to 50% during a sewing operation. The speed ranges 2...11 fit automatically to the changed maximum speed.

Adjustment:

While machine is running press pushbutton - until display indicates:

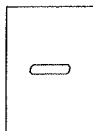

The maximum speed is thus reduced.

While machine is running press pushbutton - until display indicates:

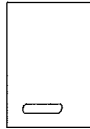

The maximum speed is thus reduced by 50%.

By pressing pushbutton + while machine is running the reduced maximum speed can be increased again or the reduction cancelled.

If one starts sewing for a short moment after the adjustment, the control memorizes the speed value, which remains saved after the switch-off of the machine.

3.6 Performance of reset

By means of a RESET all basic functions and parameters can be reset to the adjustments made by the manufacturer.

- (1) Switch off machine.
- (2) Press pushbutton P and switch on machine while keeping pushbutton depressed.

- display indicates blinking:

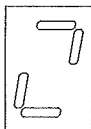

- (3) Repeatedly press pushbutton - until

- display indicates:

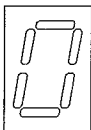

- (4) Set number 76 with pushbutton + or - according to operating step (3) in chapter 3.4 (step size = 1).

- display indicates:

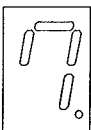

The RESET is terminated with operating step (5) or (6). Step (5) initiates a reset to the sewing mode and enables the continuation of sewing, after step (6) the programming mode is connected and the reset connection states resp. settings can be checked and, if required, readjusted (as described in chapter 3.4).

(5) Press pushbutton P shortly.

- RESET is terminated
- indication on the display disappears

(6) Press pushbutton P a bit longer.

- RESET is terminated
- display indicates blinking:

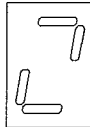

4. Parameter list

4.1 Some advices

The following description of the parameters includes the function, the setting range (from/to) resp. the possibility of adjustment (on/off), in > < the PRESET value or PRESET connection state provided by the manufacturer as well as in () the setting step by which a value or a connection state can be modified by short pressing of pushbutton + or -.

The EPROM on the P-C board is marked with the programme number of the control and with an index in form of a letter. In the following list the index from which on the respective parameter is available and thus programmable is assigned to each parameter. In addition, such an index can also be assigned to a partial range of the parameter (possibility of adjustment, PRESET value etc.), if this has become available or has been modified after the start of production. If one index or several indices are put in (), its/their availability will be confined to controls having an EPROM marked with one of these indices.

Some parameters which are provided for the setting of large spaces of time (e. g. 0...2500 ms) can only be programmed by steps (e. g. 0...9 steps). Each step comprises 4 times so that with the existing 10 steps up to 40 times are available for the settings. Within one step every short pressing of pushbutton + or - leads to the time directly superiour or inferiour without change of the step indication on the display.

The times assigned to the steps are progressive in direction of the maximum value (corresponding to the displacement of a conventional mechanic potentiometer).

The "non-mechanical thread wiper" which will be subsequently often quoted is a device which executes the "thread wiping" function by blowing air.

4.2 Fault indications

The abbreviations appear on the display in constant change.

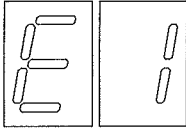

Position transmitter is not connected or is defective, or supply voltage is too low

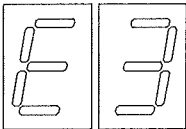

Pedal is not in basic position when machine is switched on

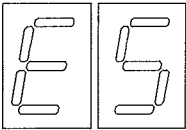

Machine blocks or does not reach the speed predetermined by the pedal position (after elimination of the fault switch motor off and on again)

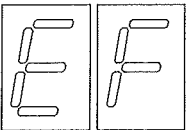

Processor in control disturbed

4.3 Parameters of technician level

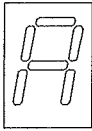

Basic position
(e. g. needle point at needle plate level)

A

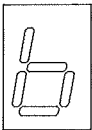

Lower needle position

A

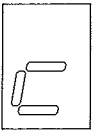

Upper needle position

A

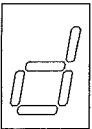

Connection point for signal FA2
(see chapter 4.4.1)

A

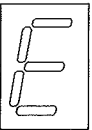

Positioning speed
60...390 RPM > 150 < (10)

A

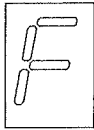

Trimming speed

A

60...390 RPM >180< (10)

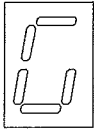

Maximum speed

A

400...9900 RPM >3000< (100)

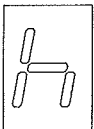

Softstart speed

A

70...990 RPM >500< (10)

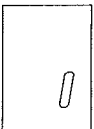

Slow stitch

A

0...9 >3< (1)

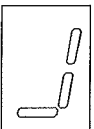

Operating time of thread wiper (for lockstitch machines and chainstitch machines with mechanical thread wiper - adjustable time: 0...2500 ms)

A

Steps 0...9 >4<

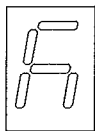

Start delay after terminated thread wiping
(for lockstitch machines)

A

Activation delay of presser foot lift
after thread trimming resp. after thread
wiping
(for chainstitch machines with mechanical
thread wiper)

Activation delay of presser foot lift
after thread trimming
(for overlock machines)

Activation delay of thread wiper
(for chainstitch machines with non-
mechanical thread wiper)

0...990 ms >80< (10)

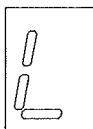

Increments for reversion
(512 increments = 1 revolution of the
handwheel)

A

0...500 >0< (10)

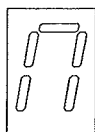

Activation delay of reversing operation

A

0...990 ms >0< (10)

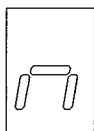

Sense of rotation of the motor

A

0 = clockwise rotation

1 = anticlockwise rotation

>1<

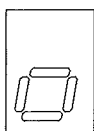

Force of partial brake during standstill
of the machine

A

Steps 0...30 >0< (1)

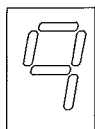

Adaptation of the control to the machine
and trimming system
(see the following diagrams of signals)

A

Control is adjusted for:

1 = lockstitch machines

2 = chainstitch machines
with mechanical thread wiper

3 = overlock machines

4 = chainstitch machines
with non-mechanical thread wiper

>1<

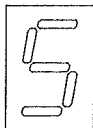

Operating time of thread trimmer
(for chainstitch machines and overlock
machines - adjustable time: 0...2500 ms)

A

Steps 0...9 > 3 <

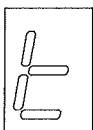

Start delay after presser foot lift
(for chainstitch machines and overlock
machines)

A

0...600 ms > 80 < (10)

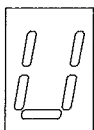

Activation delay of presser foot lift
(for chainstitch machines with non-
mechanical thread wiper -
adjustable time: 0...2500 ms)

A

Steps 0...9 > 5 <

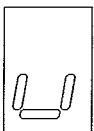

Blocking of machine run by machine switch
S68

A

- 1 = with machine switch open the machine run is blocked
(unblocking of machine run: close S68, move pedal in neutral position)
- 0 = blocking of machine run is not activated (S68 without function)

>0<

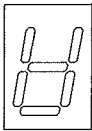

Softstart stitches after power ON

A

0 = OFF

1 = ON

>1<

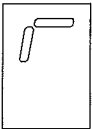

Braking effect at a speed reduction without initiation of a machine stop

A

Steps 1...25 >3< (1)

Step 25 = maximum effect

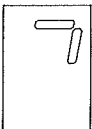

Braking effect after initiation of a machine stop until positioning

A

Steps 1...25 >10< (1)

Step 25 = maximum effect

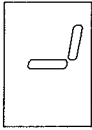

Amplification factor for speed regulation

A

Steps 0...63 $>5 <$ (1)

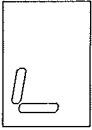

PDM Constant (PLO)

A

0...99 $>40 <$ (1)

4.4 Diagrams of signals (seam end)

4.4.1 Lockstitch machines

- Pedal -2 = pedal completely heeled back
 Pos.1 = lower needle position
 Pos.2 = upper needle position
 FA1* = thread trimmer (MI)
 FA2* = thread trimmer (MII)
 FA1+2* = thread trimmer (MIV)
 FA3 = thread wiper (MIII)
 tFA3 = operating time of thread wiper

*Depending on the thread trimmer system one of these signals is to be used.

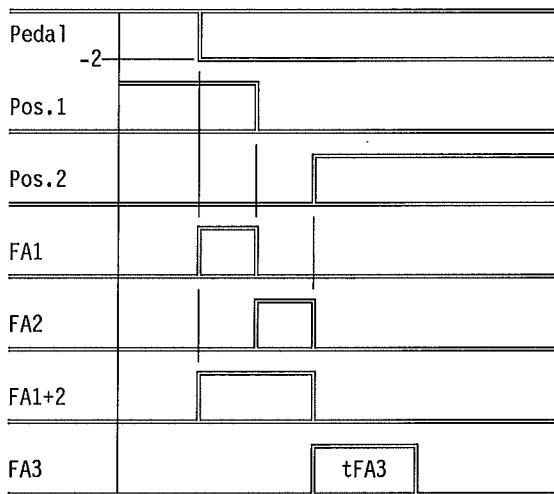

4.4.2 Chainstitch machines with mechanical thread wiper

| | |
|----------|---|
| Pedal -1 | = pedal slightly heeled back |
| Pedal -2 | = pedal completely heeled back |
| Pos.1 | = lower needle position |
| Pos.2 | = upper needle position |
| FA | = thread trimmer (MI) |
| tFA | = operating time of thread trimmer |
| FW | = thread wiper (MII) |
| tFW | = operating time of thread wiper |
| FA + FW | = signal for optional use (MIV) |
| FL | = presser foot lift (MIII) |
| tvFL | = activation delay of presser foot lift after thread trimming resp. after thread wiping |

4.4.2.1 Needle position at stop before trimming = DOWN

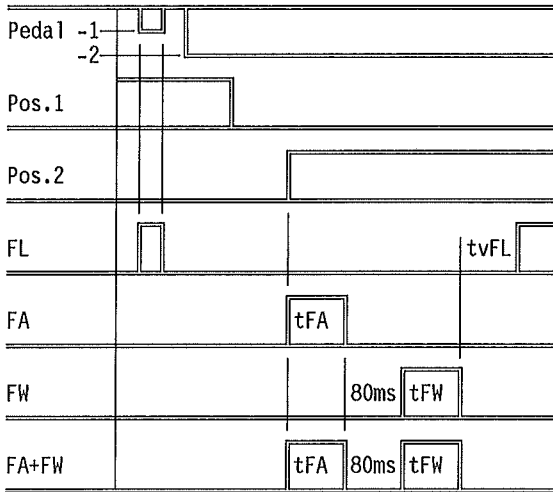

4.4.2.2 Needle position at stop before trimming = UP

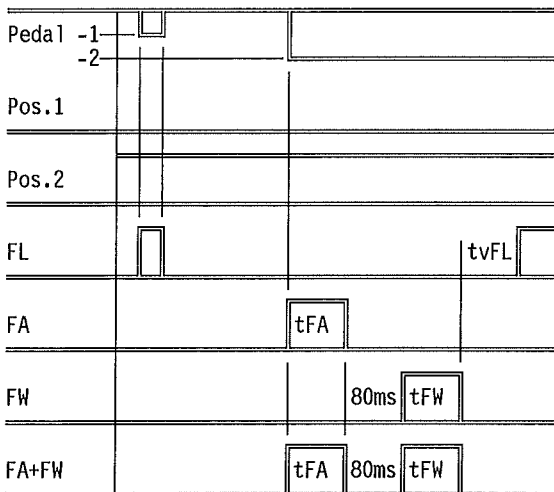

4.4.3 Chainstitch machines with non-mechanical thread wiper

| | |
|----------|---|
| Pedal -1 | = pedal slightly heeled back |
| Pedal -2 | = pedal completely heeled back |
| Pos.1 | = lower needle position |
| Pos.2 | = upper needle position |
| FA | = thread trimmer (MI) |
| tFA | = operating time of thread trimmer |
| FW | = thread wiper (MII) |
| tFW | = operating time of thread wiper |
| tvFW | = activation delay of thread wiper |
| FA + FW | = signal for optional use (MIV) |
| FL | = presser foot lift (MIII) |
| tvFL | = activation delay of presser foot lift |

4.4.3.1 Needle position at stop before trimming = DOWN

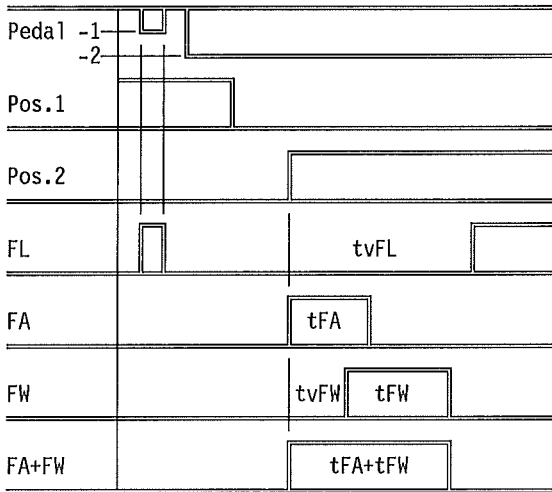

4.4.3.2 Needle position at stop before trimming = UP

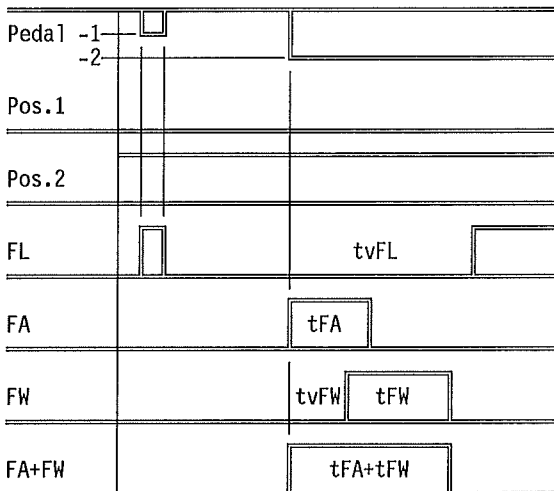

4.4.4 Overlock machines

**4.4.4.1 Needle position at stop before trimming
= DOWN or UP**

- Pedal +X = pedal actuated forward
- Pedal -1 = pedal slightly heeled back
- Pedal -2 = pedal completely heeled back
- Pos.1 = lower needle position
- Pos.2 = upper needle position
- nX = sewing speed
- n1 = positioning speed
- FA = thread trimmer (MI)
- tFA = operating time of thread trimmer
- ML = signal "machine is running"
(MII - needle cooling)
- FL = presser foot lift (MIII)
- tvFL = activation delay of presser foot lift
after thread trimming
- ML + FA = signal for optional use (MIV)

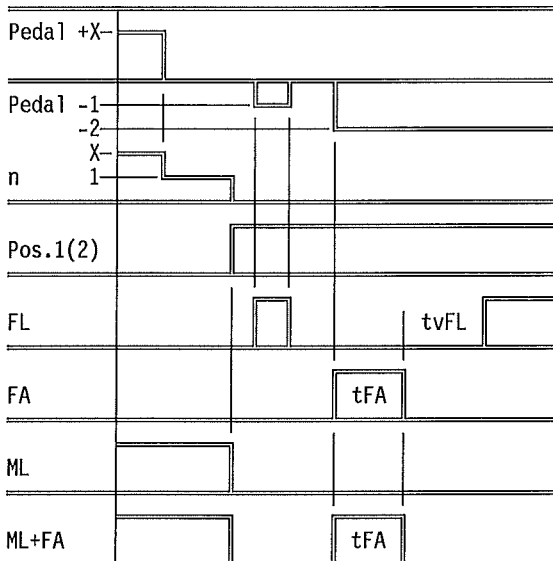

5. Connections to the sockets

Usable power packs: N102A

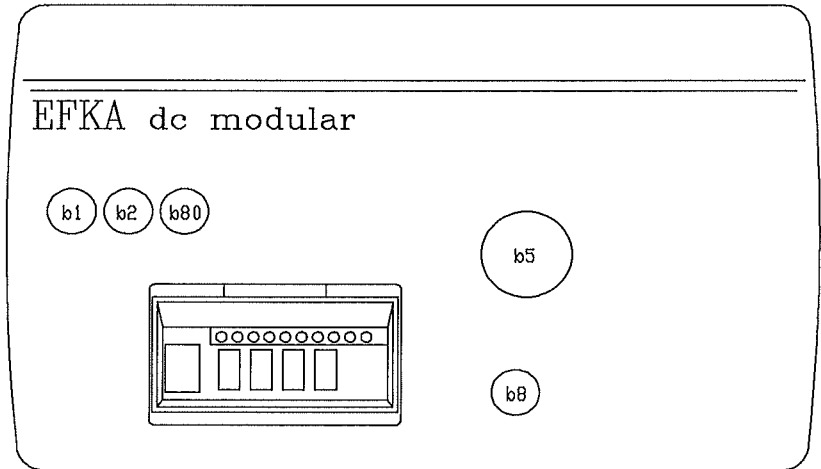

KL 1914

- b1 - socket for position transmitter P6-1
- b2 - socket for commutation of the motor
- b5, b8 - sockets for solenoids, solenoid valves and switches
- b80 - socket for external actuation EB1..

6. Connection scheme of the sockets

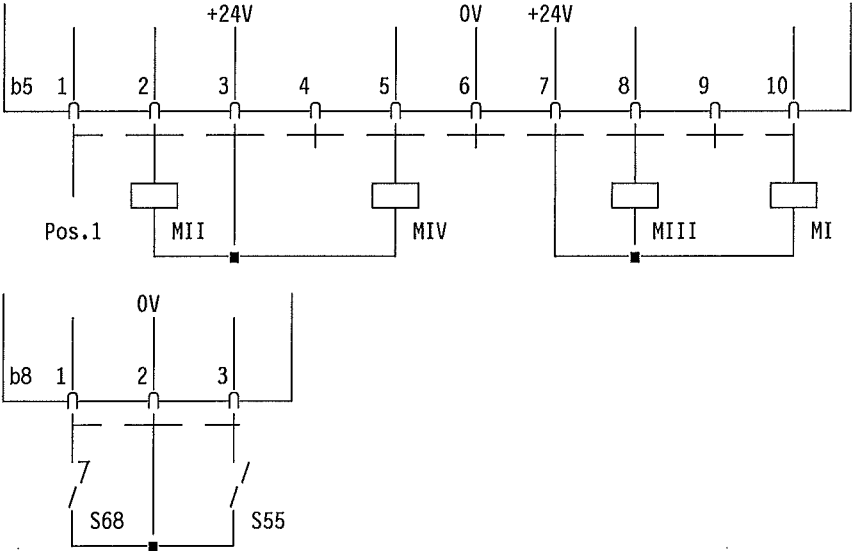

- MI - solenoid thread trimmer¹⁾²⁾³⁾
(max. 3.0A)
- MII - signal FA2¹⁾
(max. 3.0A)
- solenoid thread wiper²⁾
(max. 3.0A)
- solenoid valve needle cooling³⁾
(= signal ML)
(max. 0.7A)
- MIII - solenoid thread wiper¹⁾
(max. 3.0A)
- solenoid valve presser foot lift²⁾³⁾
(max. 0.7A)
- MIV - signal FA1 + 2¹⁾
(max. 3.0A)
- signal FA + FW²⁾
(max. 3.0A)
- signal ML + FA³⁾
(max. 0.7A)
- Pos.1 - counting signal (0V, max. 0.1A):
position 1...1.
- S55 - pulse switch (make contact) for:
NEEDLE FROM DOWN POSITION TO UP PO-
SITION / NEEDLE FROM UP POSITION TO
DOWN POSITION*
- S68 - micro switch (break contact) for:
BLOCKING OF MACHINE RUN⁴⁾
(see parameter "Blocking of machine
run by machine switch S68")

1) with lockstitch machines

2) with chainstitch machines

3) with overlock machines

⁴⁾ **CAUTION!** The switching off of the machine
necessary for maintenance and repair work is not
rendered superfluous by this device!

Plugs for sockets: b5 = part no. 500357
b8 = part no. 500402
b80 = part no. 501278

***Caution!** The pushbutton is effective within the following ranges:

- approx. 10° before the lower position up to 35° after the lower position and
- approx. 10° before the upper position up to 35° after the upper position.

Efka

FRANKL & KIRCHNER GMBH & CO KG

SCHEFFELSTRASSE 73 - POSTFACH 1320 - D-6830 SCHWETZINGEN

TEL.: (06202)2020 - TELEFAX: (06202)202115 - TELEX: 466314

Efka

OF AMERICA INC.

3715 NORTHCREST ROAD - SUITE 10 - ATLANTA - GEORGIA 30340

PHONE: (404)457-7006 - TELEFAX: (404)458-3899 - TELEX: EFKA AMERICA 804494

Efka

ELECTRONIC MOTORS SINGAPORE PTE. LTD.

67, AYER RAJAH CRESCENT 05-03 - SINGAPORE 0513

PHONE: 7772459 or 7789836 - TELEFAX: 7771048

A-1(1)-280891(206602gb)