

EFKA vario dc

CONTROL

US80A4111

INSTRUCTION MANUAL

WITH PARAMETER LIST

No. 402145

english

EFKA
FRANKL & KIRCHNER
GMBH & CO KG

EFKA
EFKA OF AMERICA INC.

EFKA
EFKA ELECTRONIC MOTORS
SINGAPORE PTE. LTD.

Contents	Page
1. Important Safety Instructions	1
2. Range of Applications	2
2.1 Use in Accordance with Regulations	2
3. Complete Drive Unit Consisting of	2
3.1 Special Accessories	3
4. Operation	3
4.1 Access to Programming on Command Input	3
4.2 The Operator Level	4
4.3 The Technician Level	4
4.3.1 Access to the Technician Level	4
4.3.2 Programming a Parameter	4
5. Starting Service	5
5.1 General Instructions	5
5.2 Initial Operation on Class 36200	6
5.3 Initial Operation on Class 34700/800	6
5.4 Fast Installation by Preset Values	6
6. Functions and Settings	7
6.1 Functions and Settings on the Operator Level	7
6.1.1 Switchable Functions	7
6.1.2 Needle Up	8
6.1.3 Limitation of the Maximum Speed	8
6.2 Functions and Settings on the Technician Level	8
6.2.1 Softstart	8
6.2.2 Thread Trimmer, Thread Wiper	9
6.2.3 Protection of the Thread Trimmer	9
6.2.4 Thread Monitor	9
6.2.5 Presser Foot Lifting	10
6.2.6 Reversion	11
6.2.7 Flatseamer	11
6.3 Machine Functions	12
6.3.1 Direction of Rotation of the Motor	12
6.3.2 Start Behavior	12
6.3.3 Braking Behavior	12
6.3.4 Braking Power at Standstill	13
6.3.5 Setting the Positions	13
6.3.5.1 Reference Position	13
6.3.5.2 Signal and Stop Positions	15
6.3.6 Supply Voltage 12V and/or 5V	16
6.3.7 External Actuator EB301 and EB302	17

7. Error Messages	17
8. Signal Test	18
8.1 Position Transmitter and Output Tests	18
8.1.1 Position Transmitter Test	18
8.1.2 Output Test	18
8.2 Input Test	19
9. Connection Diagrams	21
10. Function Diagrams	23
10.1 Trimming from Full Machine Run	23
10.2 Trimming from Intermediate Stop	24
10.3 Function Flatseamer (Basic Position 1)	25
10.4 Function Flatseamer (Basic Position 2)	26
10.5 Needle Up / Blocking of Machine Run	27
11. Parameter List	28
12. Operating Elements and Socket Connectors	33

1. Important Safety Instructions

When using an EFKA drive and accompanying appliances (e.g. for sewing machines), basic safety precautions should always be followed, including the following:

- Read all instructions thoroughly before using this drive.
 - Drive and accompanying appliances should be mounted and put into operation by qualified personnel in accordance with the guidelines provided in the instruction manual.
- To reduce the risk of burns, fire, electric shock, or personal injury:**
- Use this drive only for its intended use as described in the instruction manual.
 - Use only attachments recommended by the manufacturer or as contained in the instruction manual.
 - Do not operate without corresponding protective devices.
 - Never operate this drive if one or more parts (e.g. cables, plugs) are damaged, if it is not working properly, if any damages can be identified or are to be suspected (e.g. after it has been dropped). Only qualified personnel are authorized to make adjustments, eliminate faults and complete repair work.
 - Never operate the drive with the air openings blocked. Keep ventilation openings of the drive free from the accumulation of lint, dust and loose cloth.
 - Never drop or insert any object into any opening.
 - Do not use drive outdoors.
 - Do not operate where aerosol (spray) products are being used or where oxygen is being administered.
 - To disconnect, turn off main switch, then remove plug from outlet.
 - Do not unplug by pulling on cord. To unplug, grasp the plug, not the cord.
 - Keep fingers away from all moving machine parts. Special care is required e.g. around the sewing machine needle and the V-belt.
 - Before mounting and adjusting accompanying appliances, i.e. positioner, reversing device, light barrier, etc., disconnect drive from mains (turn off main switch, remove mains plug from outlet [DIN VDE 0113 part 301; EN 60204-3-1; IEC 204-3-1]).
 - Always switch off (0) machine and remove plug from outlet, when removing covers, mounting accompanying appliances, positioner especially, light barrier, etc., or any other devices mentioned in the instruction manual.
 - Only qualified personnel are authorized to work on the electrical components.
- Work on high voltage circuit areas is forbidden, except as stated in the respective regulations, e.g. DIN VDE 0105 part 1.
 - Only specially trained personnel are authorized to complete repair work.
 - Cables to be wired must be protected against expectable strain and fastened adequately.
 - Cables near moving machine parts (e.g. V-belts) must be wired at a minimum distance of 25 mm (see DIN VDE 0113 part 301; EN 60204-3-1; IEC 204-3-1).
 - For safety it is preferred to wire the cables separately from each other.
 - Before connecting the mains line make sure that the mains voltage corresponds to the specifications on the motor rating plate and on the nameplate of the power pack.
 - Connect this drive to a properly grounded outlet only. See Grounding Instructions.
 - Electric accompanying appliances and accessories must only be connected to safety low voltage.
 - EFKA DC drives are protected according to overvoltage class 2 (DIN VDE 0160 § 5.3.1).
 - Observe all safety guidelines before undertaking conversions or modifications.
 - For repair and maintenance use only original replacement parts.



Warnings in the instruction manual which point out particular risks of personal injury or risk to the machine are marked with this symbol wherever applicable.



This symbol is a warning on the control and in the instruction manual. It indicates hazardous voltage.

CAUTION - In the case of failure this area can be current-carrying even after having turned the power off (non discharged capacitors).

- The drive is not an independently operating unit, but is designed to be incorporated into other machinery. It must not be put into service until the machinery into which it is to be incorporated has been declared in conformity with the provisions of the EC Directive.

Save these instructions for future reference.

2. Range of Applications

The drive is suitable for sewing machines:

Brand	Series
Union Special chainstitch machines	class 34700/800, class 600, class 36200 class 37500 with Mayer -trimmer class 39500 with Mayer -trimmer

2.1 Use in Accordance with Regulations

The drive is not an independently operating machine, but is designed to be incorporated into other machinery. It must not be put into service until the machinery into which it is to be incorporated has been declared in conformity with the provisions of the EC Directive (Appendix II, paragraph B of the Directive 89/392//392/EWG and supplement 91/368/EWG).

The drive has been developed and manufactured in accordance with the respective EC standards:

EN 60204-3-1:1990 Electric equipment of industrial machines:
special requirements for industrial sewing machines,
sewing units and sewing systems.

The drive can only be operated:

- on thread processing machines
- in dry areas

3. Complete Drive Unit Consisting of

1	Direct current motor	DC....
1	Control	vario dc US80A4111
	- Power pack	N153 (optional N155)
	- Speed controller	EB301 (optional EB302, reduced actuating force)
1	Positioner	P6-1
1	Mains switch	NS105
1	Set of standard accessories consisting of:	B131 belt guard complete set of hardware motor foot bracket 1 and 2, short documentation
1	Set of accessories consisting of:	Z3 pitman rod, complete
1	Pulley	

3.1 Special Accessories

Solenoid type EM1..(for e.g. presser foot lifting, etc.)	- available versions see specification "solenoids"
Extension cable for external actuator, approx. 750 mm long, complete with plug and socket connector	- part no. 1111845
Extension cable for external actuator, approx. 1500 mm long, complete with plug and socket connector	- part no. 1111787
5-pin plug (Mas 5100W) with slide index for the connection of another external actuator	- part no. 0501278
Foot control type FB302 for standing operation with approx. 1400 mm connecting cable and plug	- part no. 1460018
Potential equalization cord 700 mm long, LIY 2.5 mm ² , grey, with forked cable brackets on both sides	- part no. 1100313
Extension cable for position transmitter P6-., approx. 1100 mm long, complete with plug and socket connector	- part no. 1100409
Extension cable for commutation transmitter, approx. 315 mm long, complete with plug and socket connector	- part no. 1111229
Extension cable for commutation transmitter, approx. 1100 mm long, complete with plug and socket connector	- part no. 1111584
Extension cable for motor connection, approx. 400 mm long	- part no. 1111858
Extension cable for motor connection, approx. 1500 mm long	- part no. 1111857
Pulley 40 mm ϕ with special belt intake and slip-off protection (use SPZ belt)	- part no. 1112223
Pulley 50 mm ϕ with special belt intake and slip-off protection (use SPZ belt)	- part no. 1112224
Knee switch type KN3 (pushbutton) with cord of approx. 950 mm length without plug	- part no. 58.0013
Sewing light transformer	- please indicate line voltage and sewing light voltage (6.3V or 12V)
3-pin plug (Mas 3100) with slide index	- part no. 0500402
4-pin plug (Mas 4100) with slide index	- part no. 0500615
6-pin plug (Meb 60)	- part no. 0500457
8-pin plug (Mas 8100 S) with slide index	- part no. 0502865
10-pin plug (Meb 100)	- part no. 0500357

4. Operation

4.1 Access to Programming on Command Input

In order to prevent the unintentional modification of preset functions the input commands are distributed at two levels.

The following persons have access:

- the operator to the first level
- the technician to both levels

4.2 The Operator Level

On this level simple functions which have to be changed frequently during operation can easily be switched on or off and/or changed by the operator.

For example, basic position needle up/down, presser foot lifting at seam end automatically on/off.

This level is always accessible when power is on, unless the technician level is open.

Note:

A changed (switched) function will only be permanently saved by a new sewing start before turning power off.

4.2 The Technician Level

On this level fundamental functions can be programmed.

4.2.1 Access to the Technician Level

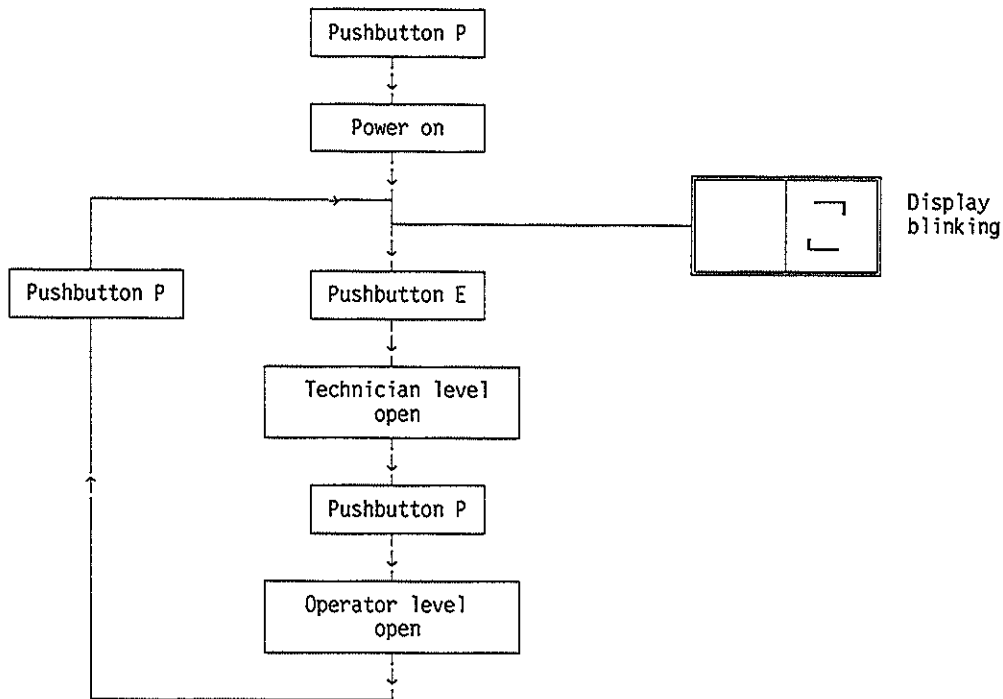

4.2.2 Programming a Parameter

1. Open technician level

Press **P** + TURN POWER ON

Display blinks ==>

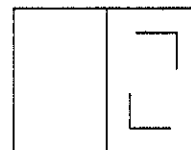

2. Set parameters

E

Parameter A ==>
= Setting the reference point

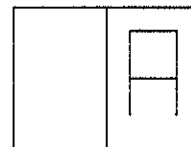

The desired parameter can be selected by pressing pushbutton E repeatedly.
The respective abbreviation appears on the display. See also chapter -Parameter List-

3. Change parameter value



Displayed value ==>
e.g. 10

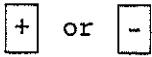
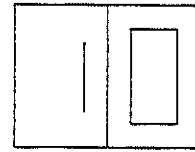

==> Change value

On with step 2.



==> Address next parameter
or 4. Close technician level

4. Close technician level



Display goes off ==>



5. Saving a changed value

A changed setting is permanently saved only after the sewing start before turning power off.

Note:

A new entry into the technician level is now possible by pressing pushbutton P again. The display shows the blinking programming mark. By pressing pushbutton E the last parameter programmed appears on the display.

5. Starting Service

5.1 General Instructions

When putting the control into operation, programming has to be done in the following manner:

- Set the direction of rotation of the motor (parameter "N")
- If necessary, set the reference position (parameter "A")
- If necessary, set the positions (parameters "B", "C", "D")
- If necessary, set the speeds (parameters "E", "G", "H")
- If necessary, set the remaining relevant parameters
- Start sewing in order to save the set values

Note:

If the power is turned off the adjustments made before starting to sew get lost.



Attention!

If the direction of rotation of the motor is changed the positions must be reprogrammed.

5.2 Initial Operation on Class 36200

- Program the direction of rotation of the motor (parameter "N" = 01)
- Set the reference position (parameter "A")
- Set the positions (parameters "B", "C", "D")
- If necessary, set the speeds (parameters "E", "G", "H")
- If necessary, set the remaining relevant parameters
- Start sewing in order to save the set values

Note:

If the power is turned off the adjustments made before starting to sew get lost.

5.3 Initial Operation on Class 34700/800

The instructions for initial operation are valid under the following conditions only:

- The positions must not have been reprogrammed.
- The direction of rotation of the motor shaft must be set to "clockwise rotation" (parameter "N" = 00).
- Before mounting the position transmitter the sewing machine shaft is to be set to the reference position.
- Markings on the position transmitter shaft and on the position transmitter housing have to be aligned, then mount the position transmitter on the sewing machine shaft.
- If necessary, set the speeds, parameters "E", "G", "H".
- If necessary, set the remaining relevant parameters.
- Start sewing in order to save the set values.

Note:

If the power is turned off the adjustments made before starting to sew get lost.

5.4 Fast Installation by Preset Values

Fast setting of the functions at values preprogrammed in the factory is possible by using this function.
(see parameter list)

Exception: direction of rotation and positions

1. Turn power off

2. Press P + TURN POWER ON

Display blinks ==>



3. Press - for about 5 seconds

until 00 appears on the display ==>

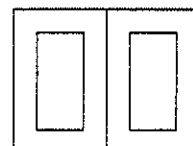

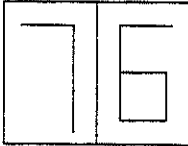
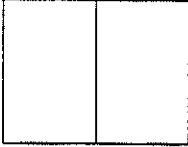
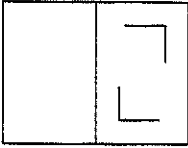
4. Press **+** or **-** several times
until 76 appears on the display ==>
- 
5. Press **P** briefly (< 2sec.)
Display goes off ==>
- The drive is ready for operation on the operator level
- 
6. Press **P** longer (> 2sec.)
Display blinks ==>
- The technician level is open for further programming
- 

6. Functions and Settings

6.1 Functions and Settings on the Operator Level

6.1.1 Switchable Functions

Switchable functions can be changed by pushbutton. The switching state is indicated by corresponding light emitting diodes (LED).

Table: Allocation of functions for the pushbuttons and LEDs

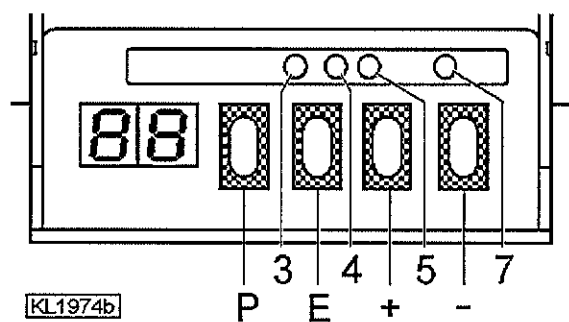

Function	Pushbutton	LED No. = on	LED No. = off
Presser foot lifting at stop in the seam (automatic)	E	3 = on	3 = off
Presser foot lifting at the seam end (automatic)	E	4 = on	4 = off
Thread trimmer and thread wiper	+	5 = on	5 = off
Basic position (at stop in the seam)	-	7 = POS2 (Needle up)	7 = POS1 (Needle down)

6.1.2 Needle Up

When actuating an external switch, the drive runs from position needle down to position needle up.

The function is activated only if the needle is within an angular range of 10° before position 1 and position 1A.

If the flatseam mode is programmed (parameter Q = 01) there is no function needle up.

6.1.3 Limitation of the Maximum Speed

By pressing the pushbuttons + or -, or while the motor is running, the programmed maximum speed can be changed.

A limitation to approx. 50% of the programmed value is possible.

The activated speed limitation is shown on the display.

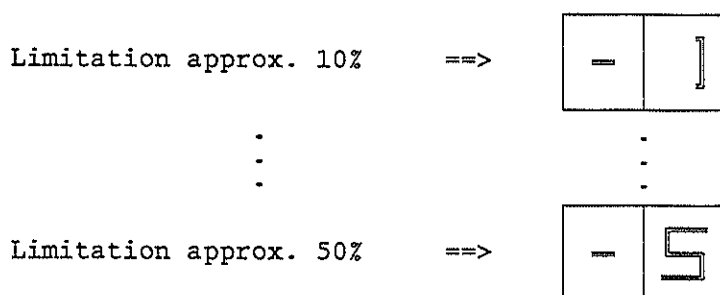

Note:

The changed setting is permanently saved only after trimming and a new sewing start.

6.2 Functions and Settings on the Technician Level

6.2.1 Softstart

Functions	Parameter
Number of Softstart stitches	I
Softstart speed	H
Softstart on/off	PC

Function:

- after power on
- at the beginning of a new seam
- speed limited (can be set by parameters), controlled by the pedal
- stitch counting is synchronized to position 1
- interruption by pedal in position 0 (neutral)
- exit by full heelback (position -2)

6.2.2 Thread Trimmer, Thread Wiper

Functions	Parameter
Activation delay of the thread wiper	J
Operating time of the thread wiper	K
Operating time of the thread trimmer	P
Thread trimming by pedal -1 on/off	R
Pulsing of the thread trimmer backward	S
Activation delay of the thread trimmer backward	T
Operating time of the thread trimmer backward	U

- The thread trimmer can be switched on or off by pushbutton +.
- The thread wiper can only be switched on or off together with the thread trimmer.
- The execution of the seam end is optimized by sensing whether or not a thread wiper is connected.
- The thread trimmer is switched on at stop in position 2 for a time that can be set by parameter P.
- Activation delay and operating time can be programmed separately each for the thread trimmer backward and the thread wiper.
- The holding power for the original position of the thread trimmer backward can be programmed. It is active even if the thread trimming function is off.
The operating time should be selected such that the solenoid maintains its original position without being overstressed.

6.2.3 Protection of the Thread Trimmer

In order to protect the thread trimmer against damage the run of the drive can be blocked by a sensor (proximity switch, hall sensor) if the thread trimmer is not in the original position.

- From machine run the drive stops in the selected basic position.
- A new sewing start is possible only after returning to the pedal position 0.
- The activated function blocking of machine run is indicated on the display by the message -A2-.
- Presser foot lifting is possible.

6.2.4 Thread Monitor

The function blocking of machine run is activated by a thread monitor signal.

- From machine run the drive stops in the selected basic position.
- A new sewing start is possible only after returning to the pedal position 0.
- The activated function blocking of machine run is indicated on the display by the message -A2-.
- Presser foot lifting is possible.

6.2.5 Presser Foot Lifting

Functions	Parameter
Activation delay of presser foot lifting	W
Start delay from lifted foot	Y
Pulse width for pulsing	PB

The connection of electromagnetic or electropneumatic presser foot lifting is possible. There is an additional unpulsed signal output at the socket B13.

Foot is lifted:

- in the seam
 - by heelback (position -1)
 - or automatically (LED 3 = on)
 - Exception:** if seam end by pedal position -1 is programmed (param. R) foot lifting is possible only by an external switch
- after thread trimming
 - by heelback (position -1 or -2)
 - or automatically (LED 4 = on)

Unintentional presser foot lifting before thread trimming, when changing from pedal position 0 (neutral) to position -2, can be prevented by setting an activation delay (param. W).

Holding power of the lifted foot:

The presser foot is lifted by full power (approx. 500ms). Then the solenoid is switched to partial power in order to reduce the load for the control and for the connected solenoid. The holding power at partial power can be set by parameter PB.



Caution!

If the holding power is set too high the solenoid and the control may be permanently damaged. Please observe the allowed operating time of the solenoid and set the appropriate value according to the table below.

Stage	Operating time	Effect
1	12.5 %	low holding power
2	25 %	
3	37.5 %	
4	50 %	
5	62.5 %	
6	75 %	
7	87.5 %	high holding power
0	100 %	full power

Foot lowers:

- from manual foot lifting, when pedal is in position 0 (neutral) (position ≥ 0)
- from automatic foot lifting, when pedal heeled forward (position > 0)

The start is delayed until the foot has securely lowered.

- delay time adjustable (param. Y)

6.2.6 Reversion

Functions	Parameter
Number of reversion increments Activation delay of reversion Positioning speed	L M E

The function "reversion" is performed after trimming.

When the stop position is reached, the drive stops for a time adjustable by parameter M. Then it reverses at positioning speed for an adjustable number of increments (param. L).

1 increment corresponds to approx 0.7°.

If the function flatseamer is on programmable reversion is inactive.

6.2.7 Flatseamer

Functions	Parameter
Flatseamer on/off	Q

The function flatseamer allows to unlock the chain at the seam end.

It is prepared by programming parameter Q = 01 (on). The function of a switch/pushbutton connected to B9/2 or B11/2 is switched from **needle up** to **flatseamer on/off**.

In the flatseamer mode there is no function "needle up".

The activated flatseamer function changes the execution of the seam end.

Thread trimmer and thread wiper as well as the programmed function reversion are turned off.

Execution when heeling the pedal back

from machine run or stop in position needle up

- set needle down
- delay according to setting by parameter M
- reversion by 180°

from stop in position needle down

- delay according to setting by parameter M
- reversion by 180°

Parameter PE influences the slowing down, when a slight change of the speed is desired (changing the pedal position by less than 5 pedal steps, e.g. from step 10 to step 6).

Parameter PF influences the slowing down, when a major change of the speed is desired (changing the pedal position by more than 4 pedal steps, e.g. for positioning from step 12 to step 0).

6.3.4 Braking Power at Standstill

Functions	Parameter
Braking power at standstill	0

This function prevents unintentional "wandering" of the needle at standstill. The effect can be tested by turning the handwheel.

- The braking power works at standstill
 - at stop in the seam
 - after trimming
- The effect can be set
- The higher the set value, the higher the braking power
- It does not work after power on, unless sewing has not been started

6.3.5 Setting the Positions

Functions	Parameter
Reference position	A
Position 1 (lower needle position)	B
Position 2 (upper needle position)	C
Position 1A (second internal switching point for the slot between position 1 and 1A)	D

6.3.5.1 Reference Position

The angular positions necessary on the machine, e.g. for needle down position or thread lever up position are stored in the control as numerical or angular values.

In order to establish a relationship between the electric position transmitter information and actual mechanical position a reference position is needed.

The reference position must be adjusted:

- for initial operation
- after changing the position transmitter
- after changing the microprocessor

Programming:**1. Open the technician level**

Press **P** + TURN POWER ON / display blinks ==>

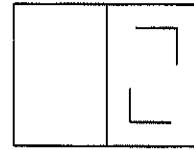
**2. Address parameter**

Press **E** Parameter A is displayed
= Setting the reference position ==>

**3. Prepare setting**

Press **+** Display 0 blinking ==>

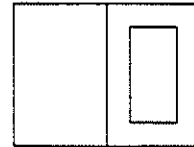
**4. Setting**

- Turn handwheel until display 0 is constant.
- Turn handwheel in the direction of rotation to half a needle bar high lift behind the bottom dead center (use caliber as setting aid)

5. Enter setting

Press **E** Display changes to next parameter, here from A to B. ==>

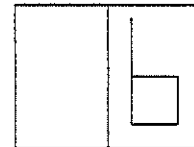
**6. Exit programming**

Press **P** Display goes off ==>
(Technician level is closed)

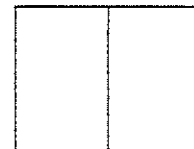
**7. Save programmed settings**

A changed setting is saved only after the sewing start before turning power off.

Note:

A new entry into the technician level is now possible by pressing pushbutton P again. The display shows the blinking programming mark. By pressing pushbutton E the last parameter programmed appears on the display.

6.3.5.2 Signal and Stop Positions

The values of the signal and stop positions are factory set. After setting the reference position, the machine is ready for operation. Settings only need to be changed on non-standard machines and/or for fine tuning.



Attention!



When using the drive for sewing machines of the class 36200, the direction of rotation and the positions 1 and 2 must be reset.

If necessary, the signal and stop positions can be set as described in chapter "Reference Positions" from step 3 onwards.

In this case pushbutton E must be pressed several times after opening the technician level until the parameter for the desired position appears on the display.

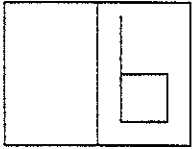
Set position 1

- | | | | |
|------------------|-----|-------------|---|
| • Actual display | ==> | Parameter B |  |
|------------------|-----|-------------|---|

- | | | | |
|---|-----|-------------------------------------|--|
| • Press  | ==> | Display for "Set position 1" blinks |  |
|---|-----|-------------------------------------|--|

- Set position 1 by turning the handwheel

- | | | | |
|--|-----|------------------------------|--|
| • or press  | ==> | Switch to the next parameter | |
|--|-----|------------------------------|--|

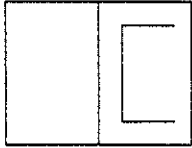
- | | | | |
|--|-----|--|---|
| • Press  to enter the setting | ==> | Display switches to the next parameter "C" |  |
|--|-----|--|---|

Set position 2

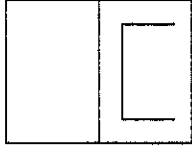
- | | | | |
|------------------|-----|-------------|---|
| • Actual display | ==> | Parameter C |  |
|------------------|-----|-------------|---|

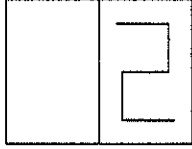

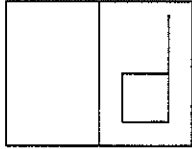

- | | | | |
|---|-----|-------------------------------------|---|
| • Press  | ==> | Display for "Set position 2" blinks |  |
|---|-----|-------------------------------------|---|

- Set position 2 by turning the handwheel

- | | | | |
|--|-----|------------------------------|--|
| • or press  | ==> | Switch to the next parameter | |
|--|-----|------------------------------|--|

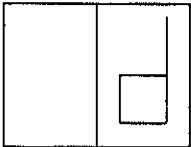
- | | | | |
|--|-----|--|---|
| • Press  to enter the setting | ==> | Display switches to the next parameter "D" |  |
|--|-----|--|---|

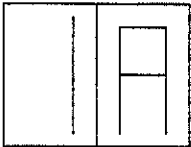
Set position 1A

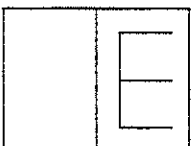
- Actual display ==> Parameter D 
- Press  ==> Display for "Set position 1A" blinks 
- Set position 1A by turning the handwheel
- or press  ==> Switch to the next parameter
- Press  to enter the setting ==> Display switches to the next parameter "E" 

Setting the positions is completed.

6.3.6 Supply Voltage 12V and/or 5V

For external devices as for ex. thread monitor, there is a supply voltage of +5V on socket B5/4. After opening the cover, this voltage can be changed to +12V by moving a jumper on the printed circuit board to a different position.



Attention!
Before opening the cover, turn power off and remove mains plug from outlet!

- +5V = Connect top pins 1 and 2 with jumper
- +12V = Connect bottom pins 3 and 4 with jumper (factory setting)

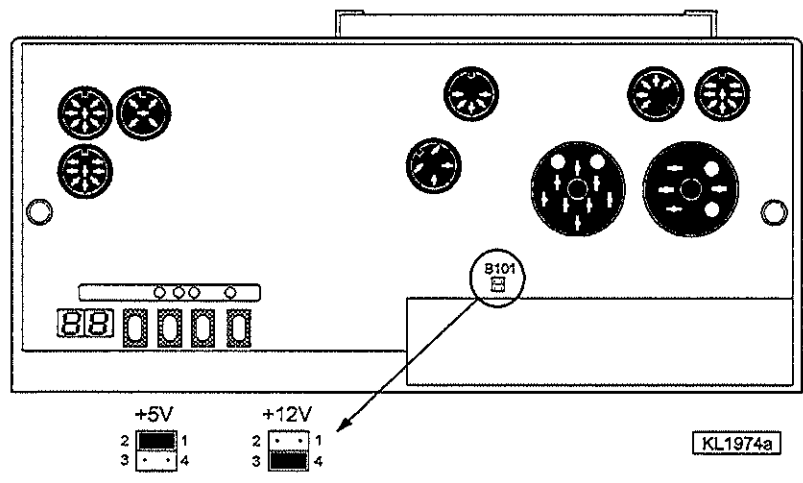

6.3.7 External Actuator EB301 and EB302

With the help of the external actuator connected with the pedal the commands for the sewing operation are inputted. Instead of the external actuator connected to the socket connector B80 (see chapter Socket Connectors) another external actuator can be connected.

The external actuator EB302 has softer springs than EB301. This means that a lower actuating force is needed.

Table: Coding of the pedal steps

Pedal step	D	C	B	A		
-2	H	H	L	L	Full heelback	(e.g. initiating the seam end)
-1	H	H	H	L	Slight heelback	(e.g. presser foot lifting)
0	H	H	H	H	Pedal in position 0 (neutral)	
$\frac{1}{2}$	H	H	L	H	Pedal slightly forward	(e.g. presser foot lowering)
1	H	L	L	H	Speed stage 1	(n_{pos})
2	H	L	L	L	-	
3	H	L	H	L	-	
4	H	L	H	H	-	
5	L	L	H	H	-	
6	L	L	H	L	-	
7	L	L	L	L	-	
8	L	L	L	H	-	
9	L	H	L	H	-	
10	L	H	L	L	-	
11	L	H	H	L	-	
12	L	H	H	H	Speed stage 12 (Pedal fully forward)	(n_{max})

L = switch contact closed, H = switch contact open

7. Error Messages

General Information

Display	Signification
A1	Pedal not in neutral position, when switching the machine on
A2	Blocking of machine run (safety switch)

Serious Situation

Display	Signification
E1	Position transmitter not connected or defective
E2	Line voltage too low, or time between power off and power on too short
E3	Machine locks, or does not reach the desired speed
E4	Control disturbed by deficient grounding or loose contact

Hardware Disturbance

Display	Signification
H1	Commutation transmitter cord or frequency converter disturbed
H2	Processor disturbed

8. Signal Test

8.1 Position Transmitter and Output Tests

Functions	Parameter
Test function position transmitter and outputs	PH

The functions of the position transmitter and of the outputs can be tested by a routine that can be activated with parameter PH.

8.1.1 Position Transmitter Test

The functions are indicated by light emitting diodes on the operation panel.

The position transmitter test can only be performed after the sewing has been started.

- Address parameter PH
- Press the + pushbutton
- Turn handwheel
 - when a position is reached, light emitting diodes are turned on
 - when a position is left, light emitting diodes are turned off
- LED 5 = on - angular position between position 1 and 1A
 - in addition LED 3 = on, signal output position 1 switched
- LED 7 = on - angular position between position 2 and 2A
 - in addition LED 3 = on, signal output position 2 switched
- Press pushbutton P or E to exit the test mode



8.1.2 Output Test

The function is indicated on the display.

For testing, the outputs below are briefly activated.

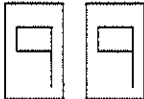
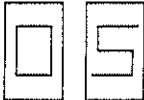
- Address parameter PH
- Press the + pushbutton; the following messages are shown on the display:

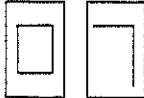
OK		All outputs o.k.
99		Error localization not possible
05		Error on B3/1-5 Presser foot lifting

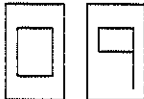
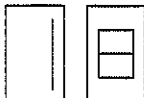
06		Error on B5/1-10 Thread trimmer backward
07		Error on B3/1-3 Motor running
08		Error on B5/1-2 Thread trimmer backward
09		Error on B3/1-6 Thread trimmer forward or B5/1-3 Thread wiper
18		Error on B13/5 Signal output presser foot lifting

If several output errors are identified they are displayed one after the other, alternating automatically.

Exit output test: Press pushbutton P or E

8.2 Input Test

Functions	Parameter
Test function inputs	PI

The input function can be tested by a routine that can be activated with parameter PI.



When the test function is activated, the actual switching state of the connected pushbuttons and switches is read and and is shown on the display by the message 00.

If the switching state of a switch changes this is indicated by a code allocated to the input.

Only one switch at a time may switch its switching state.

Test sequence

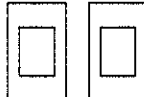
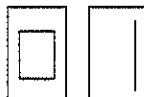
- Address parameter PI
- Press the + pushbutton; the following messages are shown on the display:

00		No change of the switching state
01		Input B5/4-6 was switched Proximity switch for thread trimmer
05		Input B9/1-3 or B11/1-3 was switched External presser foot lifting

06

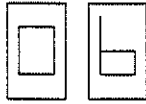

Input B9/1-2 or B11/1-2 was switched
Needle up or flatseamer

07

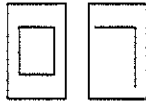

Input B6/3-4 was switched
Thread monitor

Exit input test: Press pushbutton P or E

9. Connection Diagrams

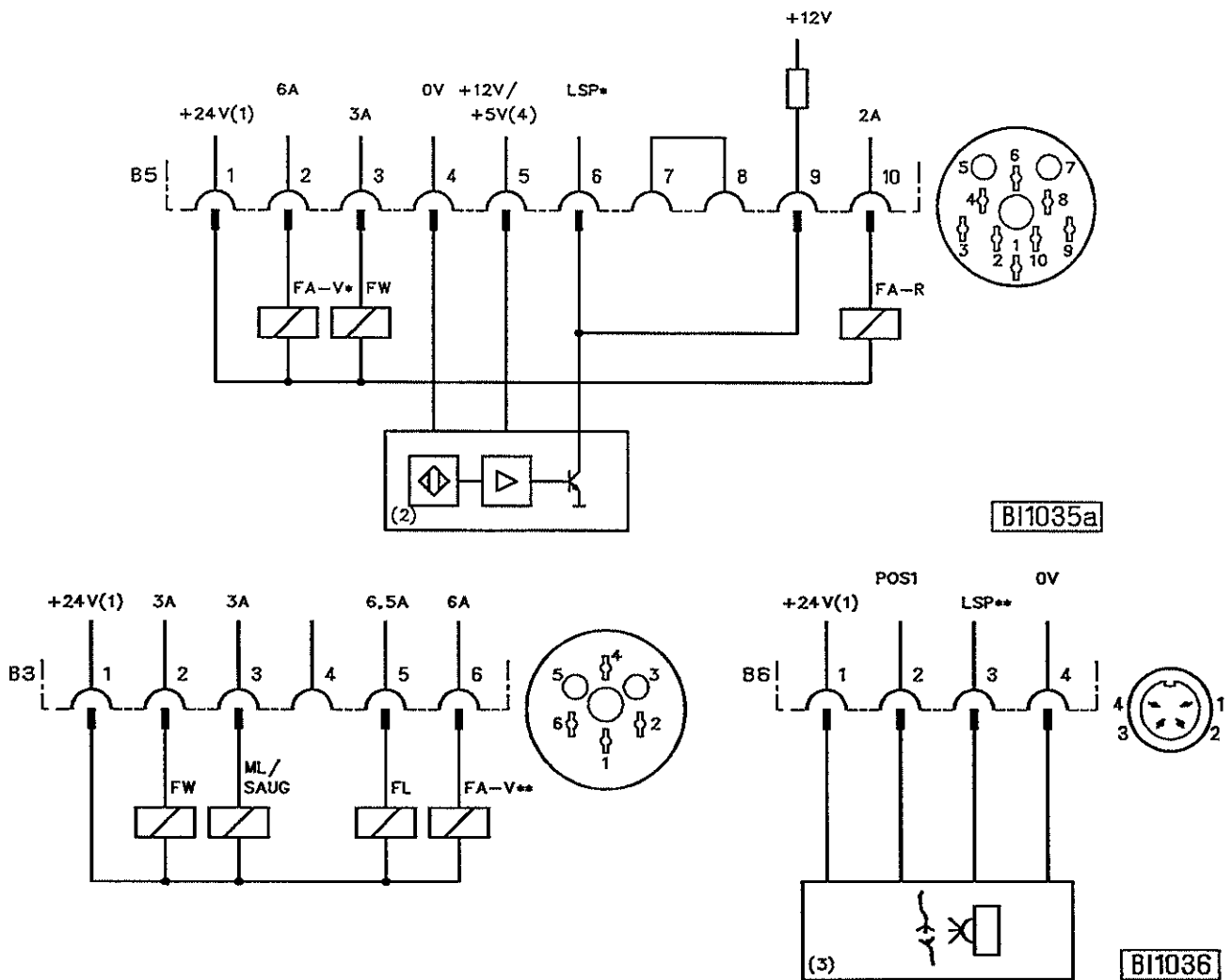

Attention!

When connecting the outputs, ensure that a total power of 96VA constant load will not be exceeded !

- FA-V* - B5/2 - Thread trimmer (class 34700/800)
- Thread trimmer forward and drawing-off of the thread/trigging of thread tension
- FA-V** - B3/6 - Mayer thread trimmer forward (class 37500 and 39500)
- FA-R - Thread trimmer backward
- FL - Presser foot lifting
- FW - Thread wiper
- LSP* - Input blocking of machine run of the proximity switch of the thread trimmer control
- LSP** - Input blocking of machine run of the thread monitor
- ML/SAUG - Motor running/ suction
- POS 1 - Transistor output as counting signal (1/rotation)

1) Nominal voltage 24V, no-load voltage max. 36V

2) Proximity switch for thread trimmer control

3) Thread monitor

4) Output +12V, 250 mA (can be changed to +5V, 250 mA after opening the cover)

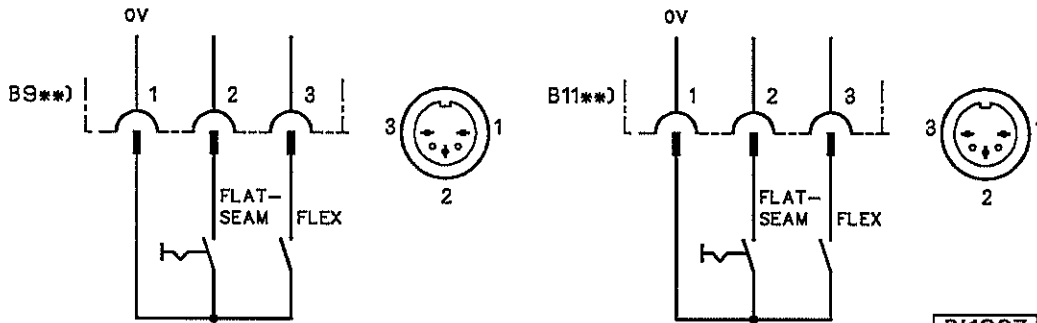
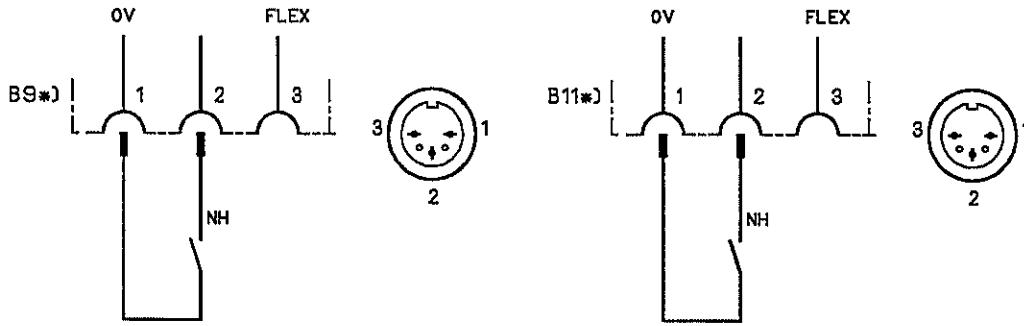

BI1037

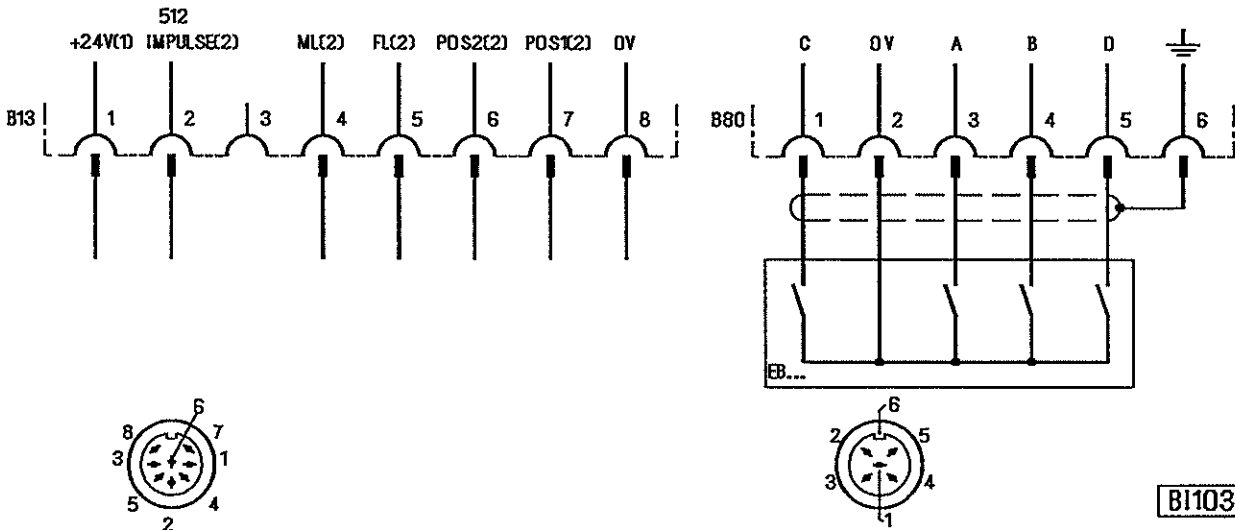

BI1038

- *) Connection diagram with function "flatseamer off" (parameter Q = 00)
- **) Connection diagram with function "flatseamer on" (parameter Q = 01)

- FLATSEAM - Switch for flatseam function
- FLEX - Pushbutton for presser foot lifting
- NH - Pushbutton for needle up
- 512 Impulse - Signal output 512 impulses / rotation
- FL - Signal output presser foot lifted
- ML - Signal output motor
- POS1 - Signal output position 1 (needle down position)
- POS2 - Signal output position 2 (needle up position)
- EB... - Actuator

- 1) Nominal voltage 24V, no-load voltage max. 36V
 - 2) Transistor output with open collector (max. 40V, 100mA)
- The signals "position 1" and "position 2" are suppressed after power on. When starting to sew, these signals will be activated. Pay attention to the time constant of the power resistor with the internal capacity (220pF) at the output of the signal "512 impulses".

10. Function Diagrams

10.1 Trimming from Full Machine Run

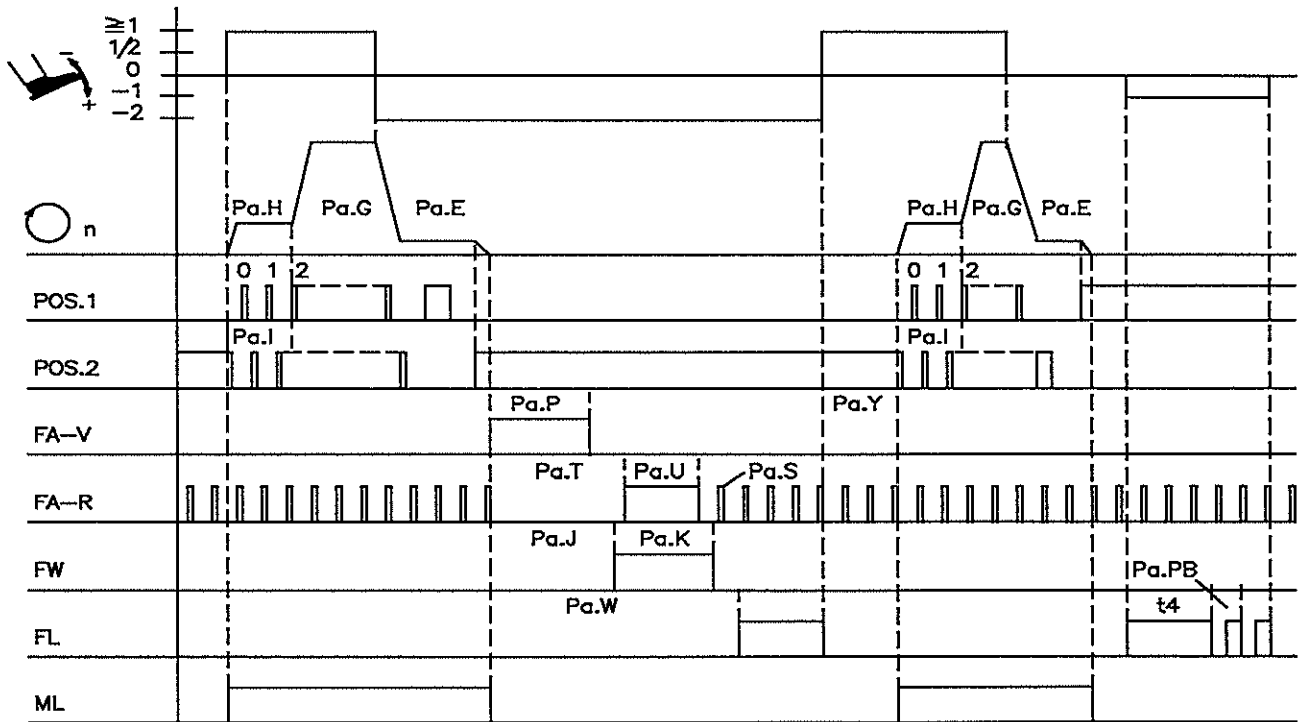

0203/KETTE1

Parameter	Function
PC	Softstart on
E	Positioning speed
G	Maximum speed
H	Softstart speed
J	Activation delay of the thread wiper
K	Operating time of the thread wiper
P	Operating time of the thread trimmer forward
S	Pulsing of the thread trimmer backward
T	Activation delay of the thread trimmer backward
U	Operating time of the thread trimmer backward
W	Activation delay of presser foot lifting
Y	Start delay from lifted foot
PB	Pulse width of presser foot lift pulsing
I	Number of Softstart stitches
t4	Time of full power of presser foot lifting fixed

Pa. = Parameter

10.2 Trimming from Intermediate Stop

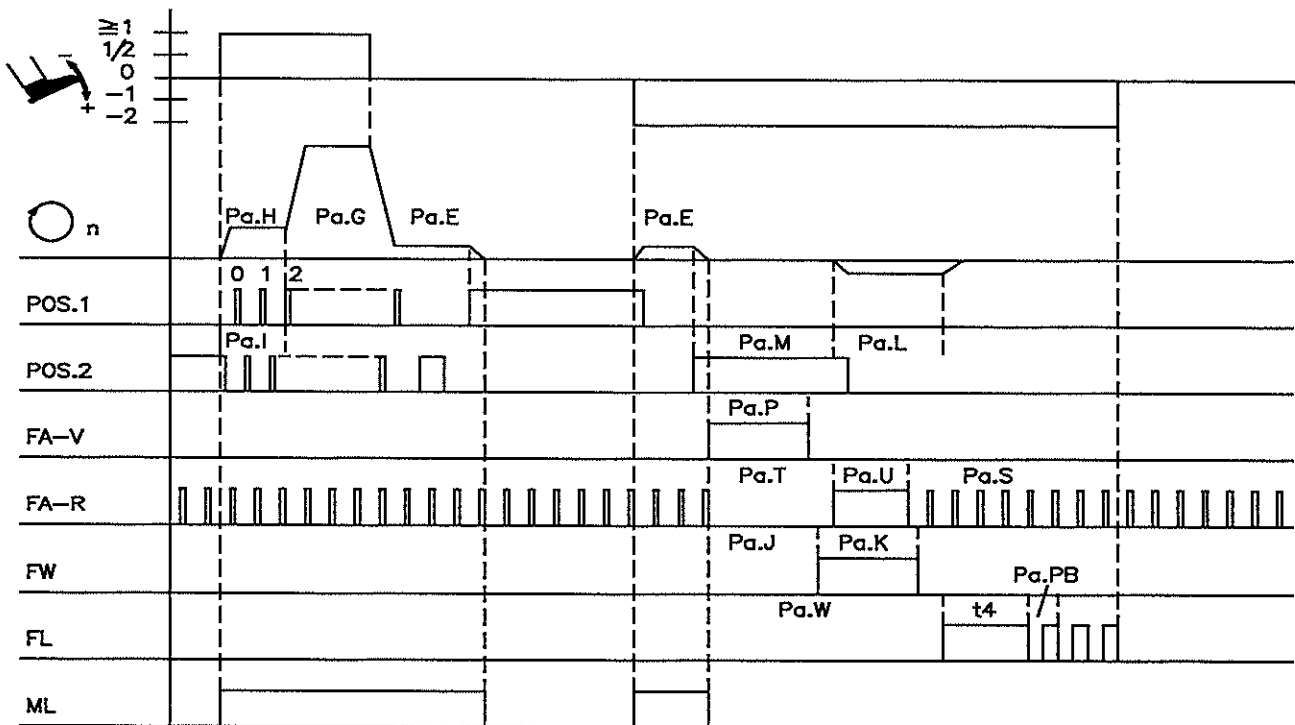

0203/KETTE2

Parameter	Function	
L	Reversion	on
PC	Softstart	on
E	Positioning speed	
G	Maximum speed	
H	Softstart speed	
J	Activation delay of the thread wiper	
K	Operating time of the thread wiper	
L	Number of reversion increments	
M	Activation delay of reversion	
P	Operating time of the thread trimmer forward	
S	Pulsing of the thread trimmer backward	
T	Activation delay of the thread trimmer backward	
U	Operating time of the thread trimmer backward	
W	Activation delay of presser foot lifting	
PB	Pulse width of presser foot lift pulsing	
I	Number of Softstart stitches	
t4	Time of full power of presser foot lifting	fixed

Pa. = Parameter

10.3 Function Flatseamer (Basic Position 1)

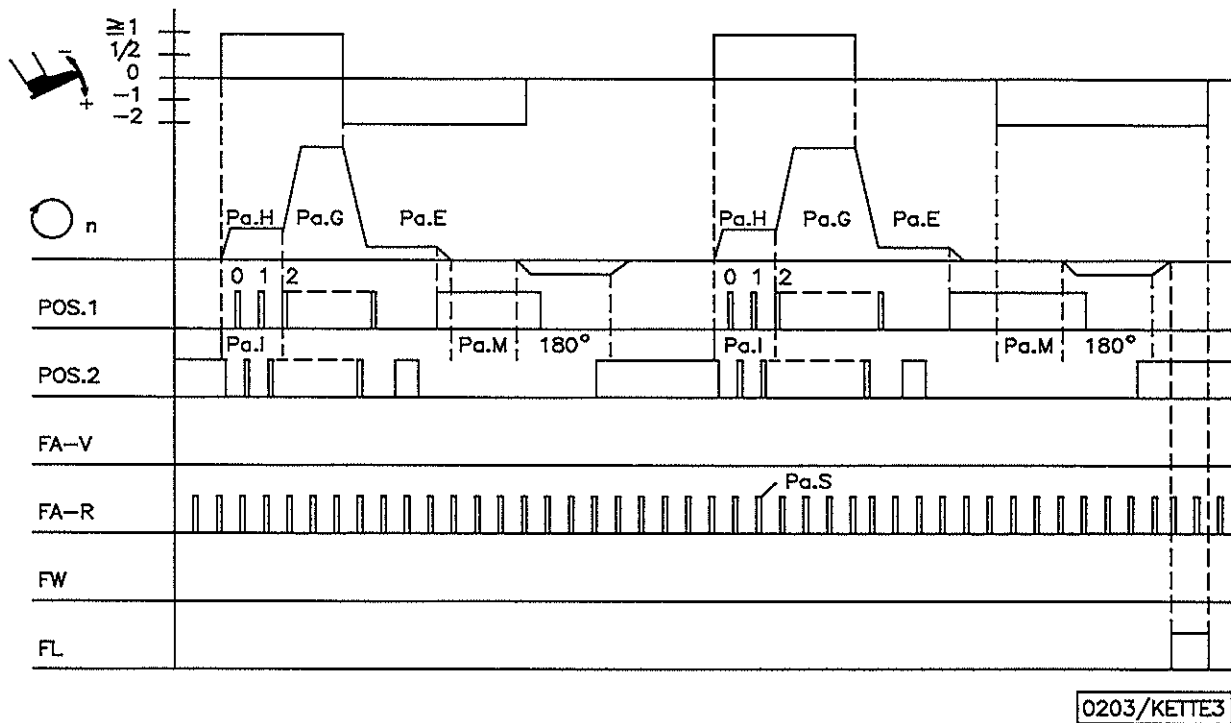

Parameter	Function	
	Basic position 1	LED 7 = off
Q	Flatseamer	on
	Switch "flatseamer" on socket B9/1-2 or B11/1-2	on
PC	Softstart	on
E	Positioning speed	
G	Maximum speed	
H	Softstart speed	
M	Activation delay of reversion	
S	Pulsing of the thread trimmer backward	
I	Number of Softstart stitches	

Pa. = Parameter

10.4 Function Flatseamer (Basic Position 2)

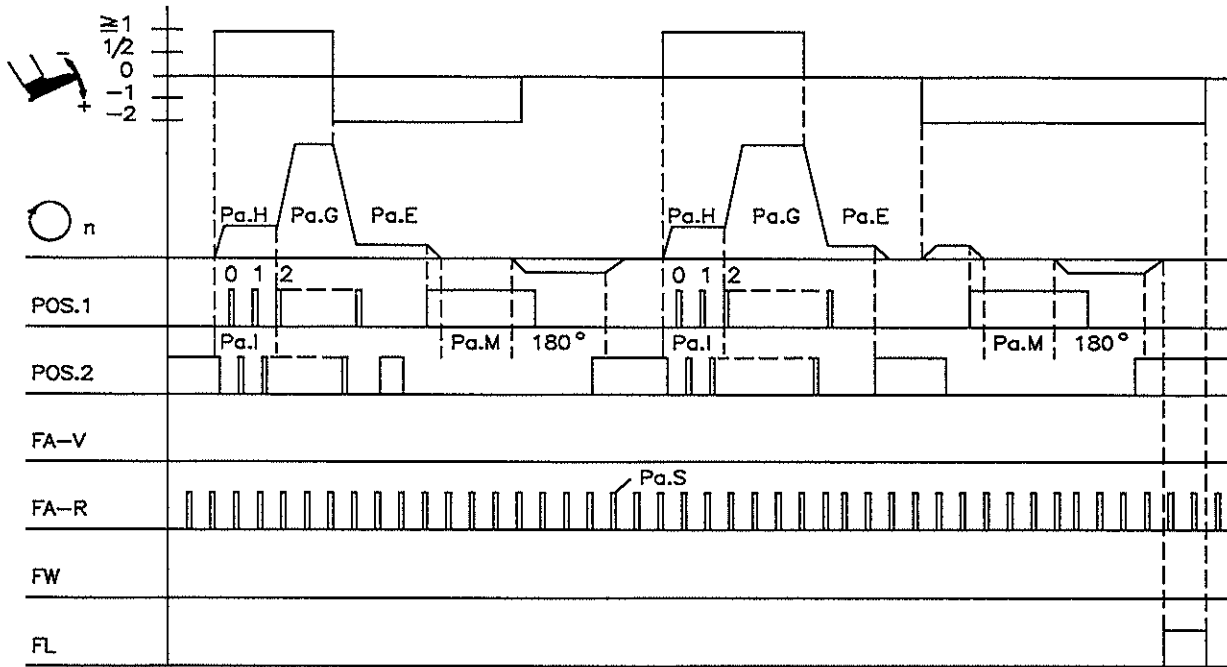

0203/KETTE3-1

Parameter	Function	
	Basic position 2	LED 7 = on
Q	Flatseamer	on
	Switch "flatseamer" on socket B9/1-2 or B11/1-2	on
PC	Softstart	on
E	Positioning speed	
G	Maximum speed	
H	Softstart speed	
M	Activation delay of reversion	
S	Pulsing of the thread trimmer backward	
I	Number of Softstart stitches	

Pa. = Parameter

10.5 Needle Up / Blocking of Machine Run

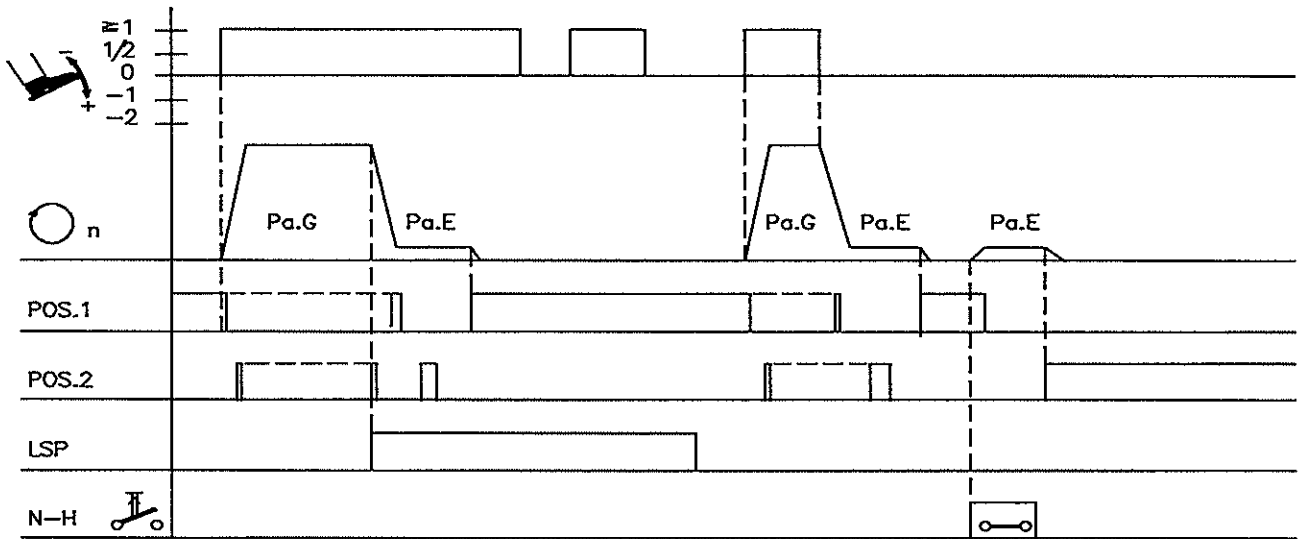

















0203/KETTE4-1











Parameter	Function
E G	Positioning speed Maximum speed
Q	Flatseamer Pushbutton "needle up" on socket B9/1-2 or B11/1-2 Switch "blocking of machine run" on socket B5/4-6 or B6/3-4

off (00)

Pa. = Parameter

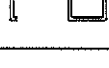
11. Parameter List

Parameter	Display	Function	Unit	Max	Min	Preset
A		Setting the reference position				
B		Setting position 1				
C		Setting position 2				
D		Setting position 1A				
E		Positioning speed, first pedal step	x 10 rpm	39	07	18
G		Maximum speed	x 100 rpm	99	04	45
H		Softstart speed	x 10 rpm	99	07	50
I		Number of softstart stitches		09	00	03
J		Activation delay of thread wiper	x 10 ms	99	00	09
K		Operating time of thread wiper	x 100 ms	25	0.0	1.1
L		Number of reversion increments	x 10 incr.	60	00	00
M		Activation delay of reversion	x 10 ms	99	00	00
N		Direction of rotation of the motor (look at motor shaft)	counterclockwise = 01 clockwise = 00	01	00	00
O		Braking power at standstill		30	00	00
P		Thread trimmer forward Operating time	x 10 ms	60	00	09
Q		Flatseamer on/off		01	00	00
R		Thread trimming by pedal -1 on/off		01	00	00

Parameter	Display	Function	Unit	Max	Min	Preset
S		Pulsing of the thread trimmer backward (0% - 18%)	%	18	00	10
T		Activation delay of the thread trimmer backward	x 100 ms	25	0.0	1.2
U		Operating time of the thread trimmer backward	x 10 ms	50	03	28
W		Activation delay of presser foot lifting	x 100 ms	25	0.0	2.7
Y		Start delay from lifted foot	x 10 ms	60	00	05
PB		Pulse width for (1 = low holding power) presser foot (7 = high holding power) lift pulsing (0 = full power)		07	00	03
PC		Softstart on/off		01	00	00
PD		Starting edge		60	01	32
PE		Braking edge 1		60	01	10
PF		Braking edge 2		60	01	32
PH		Test function for the outputs and the position transmitter				
PI		Test function for the inputs				

For your notes:

For your notes:

For your notes:

12. Operating Elements and Socket Connectors

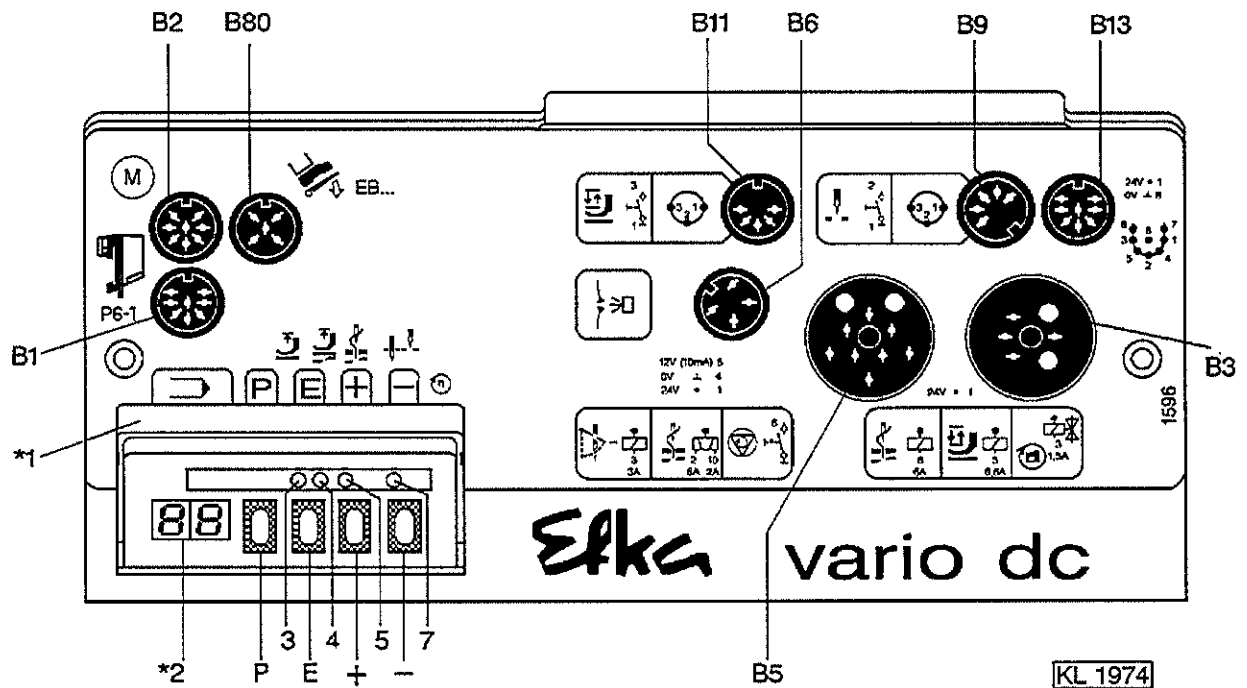

- B1 = Position transmitter
- B2 = Commutation transmitter for d.c. motor
- B3 = Solenoids
- B5 = Solenoids and sensor
- B6 = Sensor
- B9 = Switches and pushbuttons
- B11 = Switches and pushbuttons
- B13 = Output signals for automats
- B80 = Actuator

- *1 = Type designation
- *2 = Display (2-digit seven segment display)

- Pushbutton P = Recall or exit of programming mode
- Pushbutton E = Programming mode: enter button for modifications
Operator mode: automatic presser foot lifting
- Pushbutton + = Programming mode: increase of the indicated value
Operator mode: thread trimmer on/off
- Pushbutton - = Programming mode: decrease of the indicated value
Operator mode: basic position
- LED 3 = Presser foot lifting in the seam (LED on = automatic)
- LED 4 = Presser foot lifting after the seam end (LED on = automatic)
- LED 5 = Thread trimmer (LED on = on)
- LED 7 = Basic position (LED on = up)

EFKA

FRANKL & KIRCHNER GMBH & CO KG

SCHEFFELSTRASSE 73 - D-68723 SCHWETZINGEN

TEL.: (06202)2020 - TELEFAX: (06202)202115 - TELEX: 466314

EFKA

OF AMERICA INC.

3715 NORTHCREST ROAD - SUITE 10 - ATLANTA - GEORGIA 30340

PHONE: (404)457-7006 - TELEFAX: (404)458-3899 - TELEX: EFKA AMERICA 804494

EFKA

ELECTRONIC MOTORS SINGAPORE PTE. LTD.

67, AYER RAJAH CRESCENT 05-03 - SINGAPORE 0513

PHONE: 7772459 or 7789836 - TELEFAX: 7771048

1(1)-120795-A(402145EN)