

Elka variostop

CONTROL

6F62AV

INSTRUCTION MANUAL

No. 402036 english

Contents

1.	Application field of the control	3
2.	Precautions in use	4
3.	Short instructions for the operator	5
3.1	How to adjust the working speed	5
3.2	How to select the presser foot position and the backtacking mode	6
4.	Instructions for the technician	7
4.1	How to open and close the control box	7
4.2	Necessary adjustments before use	8
4.2.1	How to adjust the positioning and trimming speed	8
4.2.2	How to adjust position transmitter type P 4-1	9
4.3	How to adapt the control to the sewing machine	11
4.3.1	How to select the speed range	11
4.3.2	How to select the function of pushbutton "needle up/down"	13
4.3.3	How to adapt the speed stages to the maximum speed of the sewing machine	15
4.3.4	How to adjust the stop braking	16
4.4	How to adjust the softstart	18
4.5	How to adjust the basic position of the needle	20

4.6	How to select the presser foot position and the backtacking mode	22
4.7	How to set the stitch number for initial and final backtack	23
4.8	How to correct the stitch diagram of the initial backtack	25
5.	Previous adjustments of your control	26
6.	Definitions	27
7.	Connections to the sockets	28
8.	Connection diagram of the sockets	29

1. Application field of the control

You can use this control for the following Dürkopp sewing machines.

Classes: 2-needle machine 244-115000
and series 270

The functions of the control are distributed among two fields.

Adjustments from outside: (see figure on page 5)

with potentiometers

pos.

(17) working speed

(21) positioning and trimming speed

(24) speed for the initial backtack

(20) speed for the final backtack

(23) speed for programmed seams

(22) adaptation of the speed stages to the maximum speed of the sewing machine

(19) correction of the stitch diagram of the initial backtack

(18) starting delay after the presser foot lowering

with switches

pos.

(13) automatic presser foot lift at stop in the seam

(14) automatic presser foot lift after trimming

(15) type of initial backtack

(16) type of final backtack.

Adjustments in the control:

- speed range

- stop braking

- softstart

- basic position of the needle

- stitch number setting for initial and final backtack

- function of pushbutton "needle up without trimming" or "change of needle position".

The machine is ready for operation immediately after:

- mounting the motor and the position transmitter

- adapting the control to the sewing machine

- adjusting the needle position on the position transmitter.

2. Precautions in use

First install the control, then connect it.

Installation only with a ground conductor.

The sewing machine head has to be linked with the motor foot by a cable with a $1,5 \text{ mm}^2$ cross section.

For this purpose, you will find on the motor foot a connection screw.

Disconnect the control before connecting any additional devices.

Observe the instructions for the additional devices.

Do not use any screw driver or any other conductive tool for closing or opening the jumpers!

This may destroy the control.

3. Short instructions for the operator

3.1 How to adjust the working speed

The working speed can be adjusted while the motor is running.

Increase the speed by:

- turning potentiometer n max (17) to the right.

Reduce the speed by:

- turning potentiometer n max (17) to the left.

You can reduce the speed to half of the maximum speed.

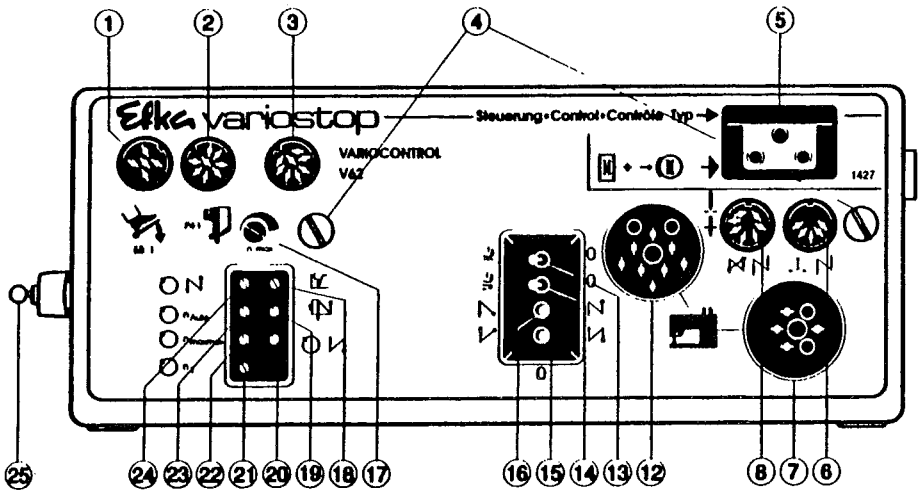

3.2 How to select the presser foot position and the backtacking mode

Switch	Function	Switch position		
		left	middle	right
(13)	Presser foot up at each stop in the seam	yes	-	no
(14)	Presser foot up after trimming	yes	-	no
(16)	Initial backtack	simple	off	double
(15)	Final backtack	simple	off	double

EFKA 6F62AV

4. Instructions for the technician

4.1 How to open and close the control box

For opening the control box

- Switch off the motor.
- Pull off all the plugs.
- Loosen the screws (4) on the control.
- Remove the front panel.

For closing the control box

- Replace the front panel.
- Tighten the screws (4).
- Insert all the plugs.
- Switch on the motor.

4.2 Necessary adjustments before use

- positioning and trimming speed
- position transmitter

4.2.1 How to adjust the positioning and trimming speed

The positioning and trimming speeds are adjusted by the manufacturer for:

class 244 150 RPM
series 270 250 RPM

Machines of series 270 have a jumper in the plug of pos. 12 between contact 4 and 5. This allows an automatic adjustment of the right positioning and trimming speed.

An adjustment will be required only in special cases. It will be performed as follows:

Note:

you need a screw driver for adjusting the potentiometer.

- Press the pedal into the first position.
Maintain this position.

Reduce the speed by:

- turning potentiometer n1 (21) to the left

Increase the speed by:

- turning potentiometer n1 (21) to the right

EFKA 6F62AV

4.2.2 How to adjust position transmitter type P4-1

- Open the position transmitter.

The slot of the central disc determines the lower needle position.

The slot of the outer disc determines the upper needle position.

- Turn the handwheel into the lower needle position
- Maintain this position.
- Turn the double disc so that the slot is located approximately in the middle of the cap.
- Start a short sewing.

The machine stops in the lower needle position (position 1).

(Commutation of the position see 4.5)

- Check the stop position.

If required, correct the needle position by turning the disc.

- Turn the handwheel into the upper needle position.
- Maintain this position.
- Turn the outer disc so that both marks on the disc coincide with the edge of the protection screen.

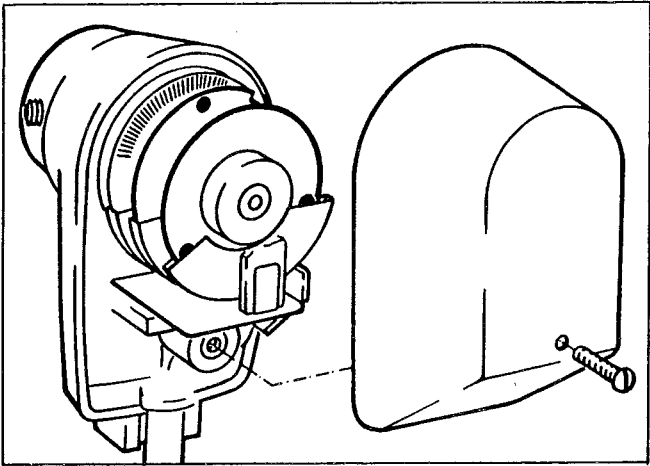

Figure 2: how to adjust the outer disc

- Start a short sewing.
- Heel the pedal back.

The machine stops in the upper needle position (position 2).

If required, correct the needle position by turning the outer disc.

- Close the position transmitter.

4.3 How to adapt the control to the sewing machine

You can:

- adjust the speed range of the sewing machine
- select the pushbutton function
- adapt the speed stages to the maximum speed
- adjust the stop braking of the motor.

4.3.1 How to select the speed range

- Open the control (see chapter 4.1).

You can see a group of 4 microswitches.

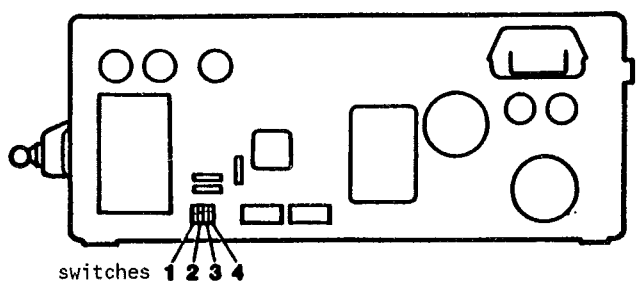

Figure 3: location of the microswitches in the control

The microswitches are rocker switches.

Figures are inscribed on one side of the rocker.

Switch 1: speed range

Switch 2: without function

Switch 3: pushbutton function

Switch 4: without function

Note:

the maximum speed of your sewing machine is to be found in the documents delivered by the sewing machine manufacturer.

Speed up to 10000 RPM.

- Press the marked side of switch 1

Speed up to 6000 RPM.

- Press the blank side of switch 1

Note:

after selecting the range for speeds up to 6000 RPM you can reach no higher speed.

- Close the control (see chapter 4.1)

4.3.2 How to select the function of pushbutton "needle up/down"

- Open the control (see chapter 4.1)

You can see a group of 4 microswitches.

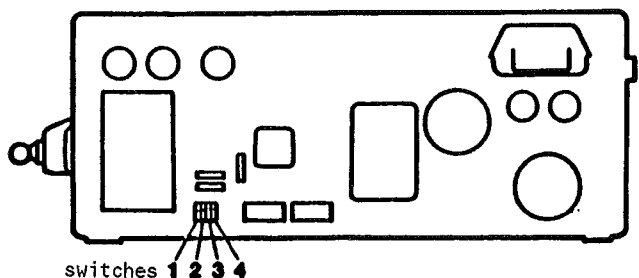

Figure 4: location of the microswitches in the control

The microswitches are rocker switches.
Figures are inscribed on one side of the rocker.

- Switch 1: speed range
- Switch 2: without function
- Switch 3: pushbutton function
- Switch 4: without function

If pushbutton "needle up/down" should have the function:

needle up without trimming

- Press the marked side of switch 3

Change of needle position

- Press the blank side of switch 3
- Close the control (see chapter 4.1)

4.3.3 How to adapt the speed stages to the maximum speed of the sewing machine

- Choose the right pulleys for the motor so that the desired maximum speed of the sewing machine can be reached .
- Turn with a screw driver potentiometer nmaxmax (22) entirely to the right.
- Turn potentiometer nmax (17) entirely to the right.
- Switch on the motor.
- Turn with a screw driver potentiometer nmaxmax (22) slowly to the left. As soon as you hear the motor slowing down stop turning.
- Turn potentiometer nmaxmax (22) again slightly to the right.

4.3.4 How to adjust the stop braking

Caution!

Do not use any screw driver or any other conductive tool for closing and opening the jumpers!

This may destroy the control.

- Switch off the motor.
- Open the control (see chapter 4.1)

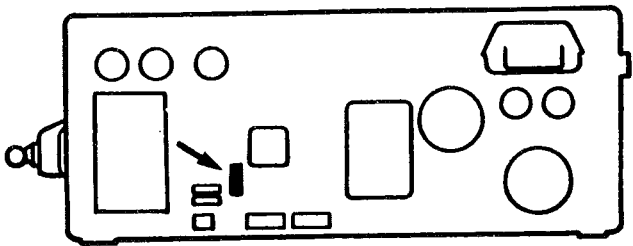

Figure 5: location of jumper 1 in the control

- Close jumper 1 carefully.

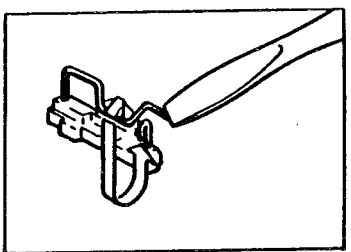

Figure 6: how to close jumper 1

- Switch on the motor.
- Adjust the desired braking effect by means of potentiometer n_{max} (17).
- Check the braking effect by turning the handwheel.
- Open jumper 1.

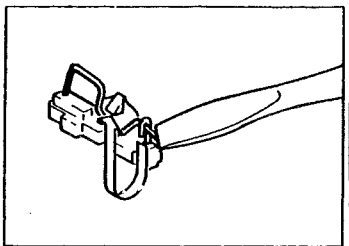

Figure 7: how to open jumper 1

Note:

you can store the adjustment of the stop braking only by opening the jumper with motor on.

- Close the control (see chapter 4.1)
- Then turn potentiometer n_{max} (17) again entirely to the right.

Note:

if you do not turn potentiometer n_{max} (17) entirely to the right the maximum speed will be limited.

4.4 How to adjust the softstart

Caution!

Do not use any screw driver or any other conductive tool for closing and opening the jumpers!

This may destroy the control.

- Open the control (see chapter 4.1)

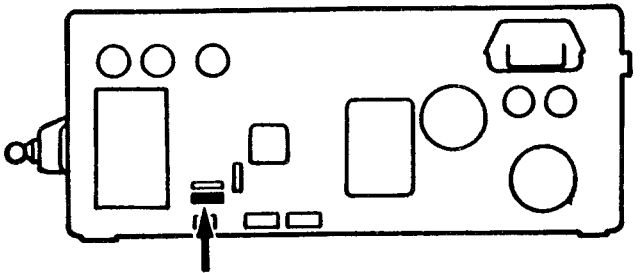

Figure 8: location of jumper 2 in the control

Connection of the softstart

- Close jumper 2 carefully.

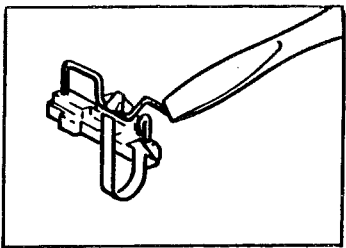

Figure 9: how to close jumper 2

If you are working with softstart the first two stitches are performed at a speed of approx. 500 RPM.

Disconnection of the softstart

- Open jumper 2 carefully.

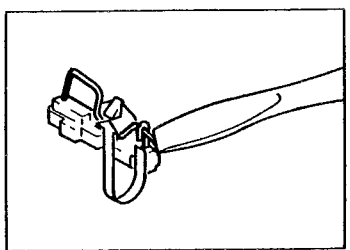

Figure 10: how to open jumper 2

- Close the control (see chapter 4.1)

4.5 How to adjust the basic position of the needle

The needle stops in the selected basic position at stop in the seam.

Caution!

Do not use any screw driver or any other conductive tool for closing and opening the jumpers!

This may destroy the control.

- Open the control (see chapter 4.1)

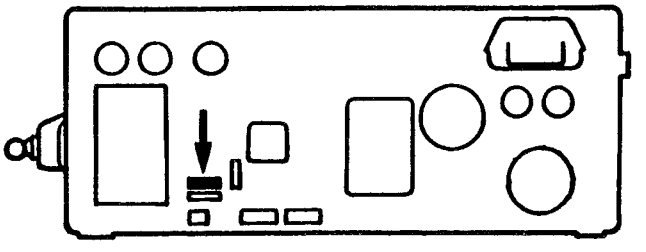

Figure 11: location of jumper 3 in the control

If the basic position of the needle is to be:

needle up

- close jumper 3 carefully.

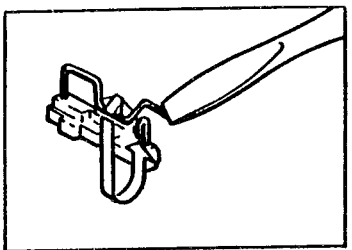

Figure 12: how to close jumper 3

EFKA 6F62AV

needle down

- open jumper 3 carefully.

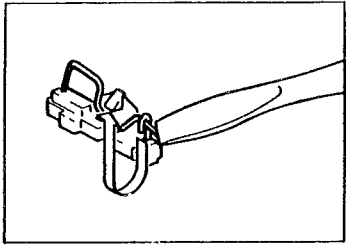

Figure 13: how to open jumper 3

- Close the control (see chapter 4.1)

4.6 How to select the presser foot position and the backtacking mode

Switch	Function	Switch position		
		left	middle	right
(13)	Presser foot up at each stop in the seam	yes	-	no
(14)	Presser foot up after trimming	yes	-	no
(16)	Initial backtack	simple	off	double
(15)	Final backtack	simple	off	double

4.7 How to set the stitch number for initial and final backtack

- Open the control (see chapter 4.1).

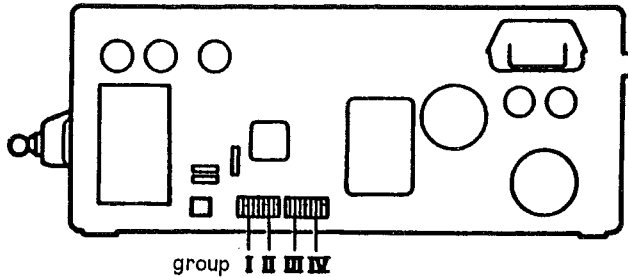

Figure 14: location of the microswitches in the control

The 16 microswitches are arranged in 4 groups, each one consisting of 4 microswitches.

Thanks to the microswitches you can define:

- Group I : stitch number for initial backtack forward
- Group II : stitch number for initial backtack backward
- Group III : stitch number for final backtack backward
- Group IV : stitch number for final backtack forward

The microswitches are rocker switches.

Figures are inscribed on one side of the rocker.

Connection states of the microswitch:

- ON : Press the marked side.
- OFF : Press the blank side.

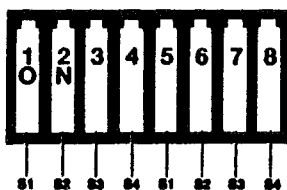

Figure 15: disposition of the microswitches in one group

Table 1: coding of the stitch number.

Number of stitches	Switches			
	S1	S2	S3	S4
0	OFF	OFF	OFF	OFF
1	ON	OFF	OFF	OFF
2	OFF	ON	OFF	OFF
3	ON	ON	OFF	OFF
4	OFF	OFF	ON	OFF
5	ON	OFF	ON	OFF
6	OFF	ON	ON	OFF
7	ON	ON	ON	OFF
8	OFF	OFF	OFF	ON
9	ON	OFF	OFF	ON
10	OFF	ON	OFF	ON
11	ON	ON	OFF	ON
12	OFF	OFF	ON	ON
13	ON	OFF	ON	ON
14	OFF	ON	ON	ON
15	ON	ON	ON	ON

- Close the control (see chapter 4.1)

4.8 How to correct the stitch diagram of the initial backtack

Due to the inertia of the stitch regulator or of solenoids the backward section of the initial backtack is generally shorter than the forward section. This difference can be adjusted with potentiometer (19).

Note!

You need a screw driver for adjusting.

Prolongation of the backward section of the initial backtack

- Turn potentiometer "correction of stitch diagram for backtack" (19) to the right.

Shortening of the backward section of the initial backtack

- Turn potentiometer "correction of stitch diagram for backtack" (19) to the left.

5. Previous adjustments of your control

The following values have been set.

Strike out the inapplicable ones or write down yours!

1. Functions	Connection state	
Speed range	10000 RPM	6000 RPM
Function of pushbutton	Needle up without trimming	Change of needle position
Softstart	yes	no
Basic position of the needle	up	down

2. Stitch number settings	Number
Initial backtack	forward
	backward
Final backtack	backward
	forward

6. Definitions

Basic position of the needle	Needle position at stop within the seam
Final backtack	Backstacking at the end of the seam automatically performed by a forward, backward and forward section.
Initial backtack	Backstacking at the beginning of the seam automatically performed by a forward, backward and forward section.
Maximum speed to position	Highest speed of the sewing machine Machine stop in certain positions (needle positions)
Positioning and trimming speed potentiometer	Adjusted lowest speed of the sewing machine, at which positioning and thread trimming are performed Adjustable electric resistance
Softstart	The first two stitches of a seam are performed at a reduced speed
Speed range	Operative range of the sewing machine limited by the positioning and trimming speed, as well as by the maximum speed
Stop braking	Braking effect at machine standstill in order to prevent the handwheel from moving by itself

7. Connections to the sockets

Socket

- (1) -External control EB1..
- (2) -Position transmitter P4-1
- (3) -Monitor V62
- (5) -Clutch and brake of the motor
- (6) -Pushbutton "manual backtack" and switch "blocking of machine run"
- (7) -"Thread wiper", "thread trimmer", "backtack" and "presser foot lift"
- (8) -Pushbutton "backtack within the seam", pushbutton "suppression of backtack/backtack call-in", pushbutton "needle up/down" and pushbutton "single stitch"
- (12) -"Thread wiper", "thread trimmer", "backtack", "presser foot lift" and connection for Select switch (jumper at 0V)

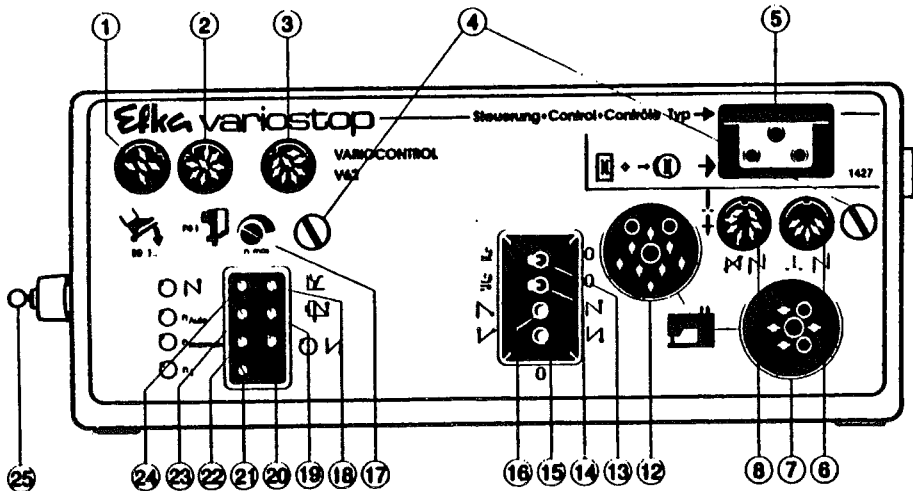

8. Connection diagram of the sockets

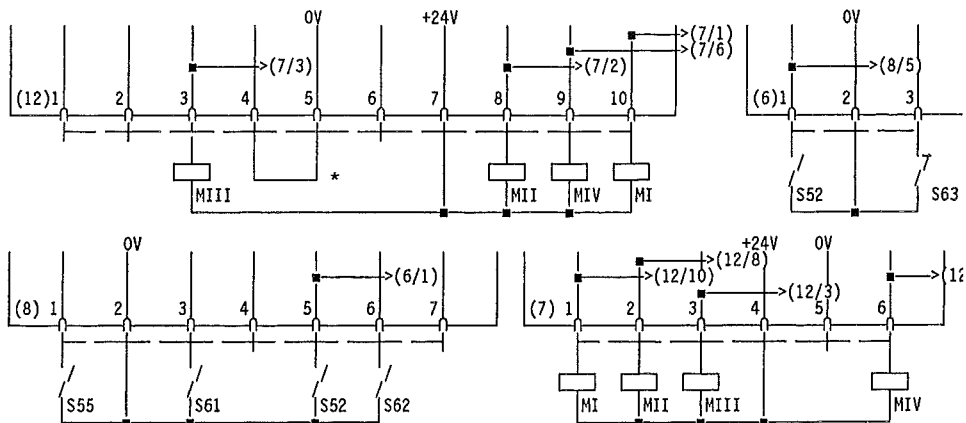

- MI - Solenoid (or solenoid valve) presser foot lift (max. 6.5A)
- MII - Solenoid thread trimmer (2.0A)
- MIII - Solenoid thread wiper (2.0A)
- MIV - Solenoid (or solenoid valve) backtack (max. 6.5A)
- S52 - Pushbutton for: BACKTACK WITHIN THE SEAM
- S55 - Pushbutton for: MOVE NEEDLE FROM UP TO DOWN POSITION
MOVE NEEDLE FROM DOWN TO UP POSITION
- S61 - Pushbutton for: SUPPRESSION OF ONE CONNECTED
INITIAL or FINAL BACKTACK and
PERFORMANCE OF ONE DISCONNECTED
INITIAL or FINAL BACKTACK**
(actuation of S61 before start of
sewing = initial backtack,
actuation of S61 within the seam =
final backtack)

* only on machines of series 270

** only in connection with monitor V62

S62 - Pushbutton for: SINGLE STITCH

S63 - Switch for: BLOCKING OF MACHINE RUN**

(S63 opened = blocking of machine run)

Caution! When blocking the machine run remove jumper R10!

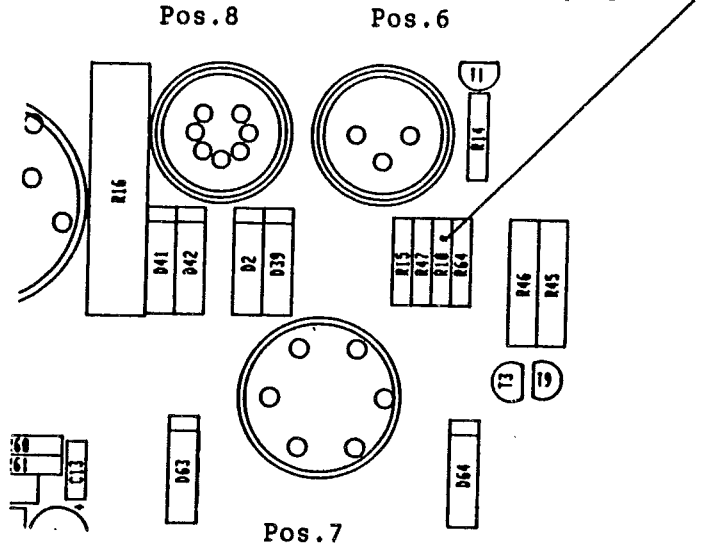

Plugs for sockets:

- (1) - part no. 0501278
- (6) - part no. 0500402
- (7) - part no. 0500457
- (8) - part no. 0502474
- (12) - part no. 0500357

Corresponding position transmitter: Type P4-1

Corresponding power packs: N13, N14

****CAUTION!** This device does not replace the switching off of the machine required for maintenance and repair work!

Efka

FRANKL & KIRCHNER GMBH & CO KG

SCHEFFELSTRASSE 73 - D-68723 SCHWETZINGEN

TEL.: (06202)2020 - TELEFAX: (06202)202115 - TELEX: 466314

Efka

OF AMERICA INC.

3715 NORTHCREST ROAD - SUITE 10 - ATLANTA - GEORGIA 30340

PHONE: (404)457-7006 - TELEFAX: (404)458-3899 - TELEX: EFKA AMERICA 804494

Efka

ELECTRONIC MOTORS SINGAPORE PTE. LTD.

67, AYER RAJAH CRESCENT 05-03 - SINGAPORE 0513

PHONE: 7772459 or 7789836 - TELEFAX: 7771048

4(3)-270194(402036gb)