

EFKA NF-COMMANDER

*Neu
New*

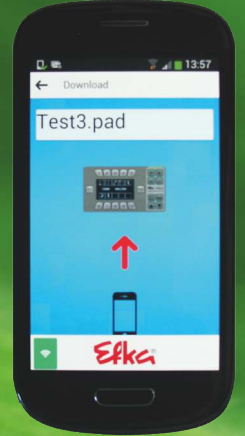

*Neu
New*



varioccontrol

V800 - V860

WWW.EFKA.NET

Bedienfelder:
Control Panels: V800, V860



Bedienfeld

- × Kompakte, flache Bauform
- × Verschiedene Befestigungsmöglichkeiten

V800

- × Großflächige 7-Segment LED-Anzeige
- × Anzeige und Tasten für die Basis Nähfunktionen
- × Direkte Änderung der Verriegelungsstichzahl über +/- Tasten

V860

- × 240x128 Punkte Grafik Display
- × Frei programmierbare Bedienoberfläche
- × Auswahl an vorprogrammierten Bedienoberflächen
- × Individuelle Zuordnung der Funktionen zu den Tasten
- × Programmierung der Steuerung über Menüführung mit grafischen Symbolen
- × Digitale Eingabe aller Parameter über numerische Tastatur
- × Programmierung direkt über Smartphone NFC Verbindung



Control Panel

- × Compact, flat design
- × Various mounting options

V800

- × Large 7-segment LED display
- × Display and buttons for the basic sewing functions
- × Direct modification of backtack stitch numbers via +/- buttons

V860

- × 240 x 128 dots graphic display
- × Freely programmable user interface
- × Selection of pre-programmed operator interfaces
- × Individual assignment of functions to the buttons
- × Programming the control system via menu navigation with graphical symbols
- × Digital input of all parameters via numerical keyboard
- × Programming directly via smart phone NFC connection



Maße

Dimensions

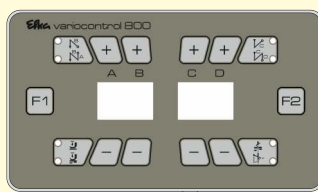
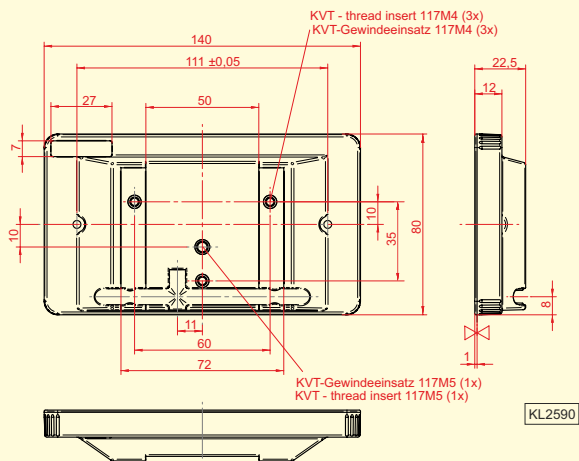

V800

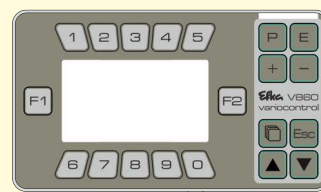

V860