



CONTROL

AB620A5035



Operating manual

With parameter list

- Putting into Service
- Settings
- Functional Description
- Connection Diagrams
- Timing Diagrams

No. 402446 English

Important Notes

The particulars used in various figures and tables, such as type, program number, speed, etc., serve as examples. They may differ from those in your display.

For current versions of the Instructions for Use and Lists of Parameters, necessary for operating EFKA drives in accordance with regulations, please refer to the EFKA web site www.efka.net, page “Downloads”.

On our web site, you will also find the following supplementary instructions for this control:

- ✘ General instructions for use and programming
- ✘ Use with USB Memory Stick
- ✘ Adapter cords

CONTENTS	Page
1 Range of Applications	6
1.1 Use in Accordance with Regulations	6
2 Scope of Supply	7
2.1 Special Accessories	7
2.1.1 Adapter Cords for Special Machines	8
3 Putting into Service	8
4 Setting and Putting into Service with the Aid of the Fast Installation Routine (SIR)	9
5 Quick access	13
5.1 Parameter back up	13
5.1.1 Parameter backup	13
5.1.2 Restoring parameters from the backup	13
5.1.3 Save the parameter backup on a USB stick	14
5.1.4 Restoring the parameter backup from the USB stick	15
5.2 Setting the reference position	16
6 Setting the Basic Functions	17
6.1 Direction of motor rotation	17
6.2 Use of a HSM001 Hall Sensor Module or IPG... Pulse Encoder	17
6.3 Transmission Ratio	18
6.4 Selection of Functional Sequences (Thread Trimming Operations)	18
6.5 Functions of the Keys Inputs in1...in7	18
6.6 Positioning speed	18
6.7 Maximum Speed Compatible with the Sewing Machine	19
6.8 Maximum speed	19
6.9 Positions	19
6.9.1 Setting the reference position (Parameter 170)	20
6.9.2 Setting the Positions	21
6.10 Display of the Signal and Stop Positions	21
6.11 Positioning shift	22
6.12 Braking Characteristics	22
6.13 Braking Power at Standstill	22
6.14 Starting Characteristics	23
6.15 Actual Speed Display	23
6.16 Operating hours counter	23
6.16.1 Set and Reset Operating Hours Counter	25
6.16.2 Total Operating Hours Display	25
7 Functions with or without Control Panel	25
7.1 First Stitch after Power On	25
7.2 Softstart	25
7.2.1 Softstart speed	25
7.2.2 Softstart stitches	26
7.3 Sewing foot lifting	26
7.4 Start Backtack/Start Stitch Condensing	27
7.4.1 Speed n3 at the Start of the Seam	27
7.4.2 Stitch Counting for Start Backtack/Start Stitch Condensing	28
7.4.3 Stitch Correction and Speed Release	28
7.4.4 Double start backtack	28

7.4.5	Single Start Backtack / Start Stitch Condensing	28
7.5	End Backtack / End Stitch Condensing	28
7.5.1	Speed n4 at the Seam End	29
7.5.2	Stitch Counting for End Backtack/End Stitch Condensing	29
7.5.3	Stitch Correction and Last Stitch Backward	29
7.5.4	Double End Backtack/End Stitch Condensing	29
7.5.5	Single End Backtack / End Stitch Condensing	30
7.5.6	Backtack Synchronization	30
7.6	Start Ornamental Backtack/Stitch Condensing	30
7.7	End Ornamental Backtack/Stitch Condensing	30
7.8	Intermediate Backtack	31
7.9	Stitch Regulator Suppression/Recall	32
7.10	Holding Power of the Stitch Regulator Solenoid	32
7.11	Reverse motor rotation	32
7.12	Unlocking the Chain (Mode 5/6/7)	33
7.13	Machine run blockage	34
7.14	High lift for walking foot / flip-flop 1	34
7.14.1	High lift walking speed	34
7.14.2	High Lift Walking Speed Run-Out Time	35
7.14.3	High Lift Walking Stitches	35
7.14.4	High Lift for Walking Foot Operational Mode Not Stored (Parameters 240...246 = 13)	35
7.14.5	High Lift for Walking Foot Operational Mode Stored /Flip-Flop 1 (Parameters 240...246 = 14)	35
7.15	Speed Limitation Depending on High Lift	35
7.15.1	Programming the measurement value of the poti	36
7.16	Speed Limitation n9	36
7.17	Thread trimming operation	36
7.17.1	Thread Trimmer/Thread Wiper (Lockstitch Modes)	37
7.17.2	Trimming speed	37
7.17.3	Chainstitch thread cutter (var. modes)	37
7.17.4	Chainstitch Machine Trimming Signal Times	37
7.18	Functions for bag sewing machines	38
7.19	Overlock Machine Functions (Mode 7)	38
7.19.1	Chain Suction Signal	38
7.19.2	Start and End Counts	40
7.20	Tape Cutter/Fast Scissors (Modes 6/7)	40
7.20.1	Tape Cutter/Fast Scissors in Mode 6	40
7.20.2	Tape Cutter/Fast Scissors in Mode 7	40
7.21	Manual Tape Cutter/Fast Scissors	41
7.22	FlipFlop functions (AFF)	42
7.23	Seam with Stitch Counting	43
7.23.1	Number of Stitches for a Seam with Stitch Counting	43
7.23.2	Stitch Counting Speed	43
7.23.3	Seam with Stitch Counting When Light Barrier Is On	43
7.24	Free Seam and Seam with Light Barrier	44
7.25	Light barrier	44
7.25.1	Speed after Light Barrier Sensing	44
7.25.2	General Light Barrier Functions	44
7.25.3	Reflection Light Barrier LSM002	45
7.25.4	Automatic Start Controlled by Light Barrier	45
7.25.5	Light barrier filter for knitted fabrics	45
7.25.6	Functional Variations of the Light Barrier Input	46
7.26	Switching Functions of Inputs in1...i13	47
7.27	Software Debouncing of All Inputs	48
7.28	F1/F2 Function Key Assignment on the V810/V820 Control Panels	48
7.29	Special pedal function Single stitch / Full stitch	49
7.30	Signal "Machine Running"	49
7.31	Signal Output Position 1	49
7.32	Signal Output Position 2	49

7.33	Signal Output 512 Impulses per Rotation	49
7.34	Actuator	50
7.34.1	Analog actuator	50
8	Signal Test	50
8.1	Signal Test Using the Incorporated Control Panel or the V810/V820	51
8.1.1	Inputs to the control	51
8.1.2	Outputs of control	51
9	Table of Machine Functions and Adapter Cords	52
10	Operating Elements and Socket Connectors	54
10.1	Positions of the Front Side	54
10.2	Positions of the rear side	54
10.3	Connection Diagrams	55
11	Timing Diagrams	60
11.1	Operator Level	80
11.2	Technical level (Code no. 1907)	83
11.3	Supplier level (Code No. 3112)	88
12	Error Displays	96

1 Range of Applications

The drive is suitable for lockstitch, chainstitch and overlock machines of various manufacturers.

It can be operated with or without control panel.

The easy-to use V810 or V820 control panels extend the range of functions.

With the help of adapter cords (adapter cords see Special Accessories), the drive can be used in replacement of the controls listed in the table below, as long as backtacking, stitch condensing, and chain suction are not used.

Machine manufacturer	Replacing	Machine	Model	Thread trimming mode	Adapter cord
Aisin	AB62AV	Lockstitch	AD3XX, AD158, 3310, EK1	0	1112815
Brother	AB62AV	Lockstitch	737-113, 737-913	0	1113420
Brother	AC62AV	Chainstitch	FD3 B257	5	1112822
Dürkopp Adler	DA62AV	Lockstitch	210, 270	0	1112845
Global		Chainstitch	CB2803-56	5	1112866
Juki	AB62AV	Lockstitch	5550-6	14	1112816
Juki	AB62AV	Lockstitch	5550-7, 8500-7, 8700-7	14	1113132
Kansai	AC62AV	Chainstitch	RX 9803	5	1113130
Pegasus	AC62AV	Chainstitch	W500/UT, W600/UT/MS, with/without stitch condensing	5	1112821
Pegasus	AB60C	Backlatch		8	1113234
Pfaff	PF62AV	Lockstitch	563, 953, 1050, 1180	0	1113746
Rimoldi		Chainstitch	F27	5	1113096
Singer	SN62AV	Lockstitch	212 UTT	2	1112824
Union Special	AC62AV	Chainstitch	34700 with stitch lock	5	1112844
Yamato	AC62AV	Chainstitch	VC series	5	1113345
Yamato		Chainstitch	VG series	5	1113345
Yamato	AB60C	Backlatch	ABT3	9	1112826
Yamato		Backlatch	ABT13, ABT17	9	1113205
Medium-duty sewing machine, general		Lockstitch	e.g. Dürkopp Adler, Juki, Pfaff, Sunstar, Golden Wheel	3	Suitable adapter, upon request

1.1 Use in Accordance with Regulations

The drive is not an independent functional machine. It has been designed for integration into other machines by trained specialists.

It must not be put into service until the machinery into which it is to be incorporated has been declared in conformity with the provisions of the EC Directive (Appendix II, paragraph B of the Directive 89/392/EEC and supplement 91/368/EEC).

The drive has been developed and manufactured in accordance with the relevant EC standards:

IEC/EN 60204-31 Electrical equipment of industrial machines:

Particular requirements for industrial sewing machines, sewing units and sewing systems.

Operate the drive only in dry areas.



ATTENTION

When selecting the installation site and the layout of the connecting cable, the Safety Instructions must be followed with no exceptions.

Particular attention should be paid to maintaining the proper distance from moving parts!

2 Scope of Supply

Standard Scope of Supply		
1	Direct current motor	DC1200 optional DC1250
1	Electronic control/Power supply unit	AB620A5035N214
1	Set of accessories (standard)	B156
	Consisting of:	Plastic bag for B156 + documentation
and		
1	Set of accessories	Z55
	Consisting of:	37-contact SubminD plug, potential equalization cord
Option 1		
1	Actuator	EB401
and		
1	Set of accessories	Z66
	Consisting of:	37-contact SubminD plug, tension rod, potential equalization cord
Additional options		
	Below table assembly set	Z71 AB6..-DC12.. Below table assembly
	Pulse encoder IPG001	Z72 AB6..-DC12.. IPG

NOTE

If there is no metallical contact between drive (motor) and machine head, the potential equalization cord supplied with the unit is to be wired from the machine head to the terminal provided on the control box!

2.1 Special Accessories

The special accessories available ex works allow the augmentation and enhancement of functions, operating, connecting, and mounting options.

Since the range of available components is continually expanded, we kindly ask you to contact us in case of need.

Designation	Material No.
Control panel Variocontrol V810	5970153
Control panel Variocontrol V820	5970154
Control panel Variocontrol V860	5990164
Reflection light barrier module LSM002	6100031
Hall sensor module HSM001	6100032
Pulse encoder IPG001	6100033
Adapter cord for the connection of light barrier module and/or Hall sensor module HSM001 and/or pulse encoder IPG001	1113229
Extension cable approx. 1000 mm long for commutation transmitter DC12.. + DC15..	1113151
Extension cable approx. 1000 mm long for Netz DC12.. line + DC15..	1113931
Potential equalization cord 700 mm long, LIY 2.5 mm ² , gray, with spades on both sides	1100313
Foot control type FB302B with three pedals for standing operation, with approx. 1400 mm connecting cable and plug	4170025
Fitting piece for position transmitter	0300019
Knee switch type KN19 (pushbutton) with cord of approx. 450 mm length and western plug (RJ11)	5870021
Knee switch type KN20 (pushbutton + selector switch) with cord of approx. 1640 mm length and Western plug (RJ11)	5870022
Adapter set for DC12. + DC15.. on PEGASUS model W600	1113125
Adapter set for DC12. + DC15.. on PEGASUS Ex/Ext	1113126
Adapter set for DC12. + DC15.. on PEGASUS model W1500N, W1600	1113647
Undertable mounting kit for DC1200/DC1250	1113956
Undertable mounting kit for DC1500/DC1550	1113427

9-contact SubminD male connector	0504135
9-contact SubminD female connector	0504136
Half-shell housing for 9-contact SubminD	0101471
37-contact SubminD male connector, complete	1112900
Single pins for 37-contact SubminD with strand of 50 mm length	1112899
Adapter set direct drives DC1210 & DC1230	
Mounting kit for DC1210 on JUKI M067, M069	1114085
Mounting kit for DC1210 on JUKI M068	1114093
Mounting kit for DC1210 on PEGASUS EX	1114082
Mounting kit for DC1210 on PEGASUS M900	1114088
Mounting kit for DC1210 on YAMATO AZ, CZ	1114084
Mounting kit for DC1230 on PEGASUS chainstitch	1114119
Mounting kit for DC1230 on YAMATO VC, VE, VF, VG	1114102

2.1.1 Adapter Cords for Special Machines

For interconnection diagrams of the adapter cords, please refer to our web site at www.efka.net/downloads.

Machine / Type / Model	Material No.
AISIN high-speed seamer AD3XX, AD158, 3310 and overlock machine EK1	1112815
BROTHER models 737-113, 737-913	1113420
BROTHER Lockstitch machines, with 100 Ω selective resistance, cl. 7xxx, B84xx, 877B, B87xx, 878B (mode 31)	1113420
BROTHER chainstitch machines, with 150 Ω selective resistance, cl. FD3-B257, 25xx, 26xx, 27xx (mode 32)	1112822

Designation	Material No.
BROTHER models B721, B722, B724, B737, B748, B772, B774, B778, B842, B845, B872, B875 <i>Connection of the position sensor incorporated in the hand wheel</i>	1113433
DÜRKOPP ADLER models 210 and 270	1112845
GLOBAL model CB2803-56	1112866
JUKI high-speed seamer with index -6	1112816
JUKI high-speed seamer with index -7	1113132
JUKI lockstitch machines <i>Connection of the position sensor incorporated in the hand wheel</i>	1113157
JUKI DNU1541, LU2210, LU1510	1114023
JUKI LU2810-6	1114024
JUKI PLC 2760	1114025
KAISER models 1245 & 335	1114003
KANSAI machines model RX 9803	1113130
PEGASUS models W500/UT, W600/UT/MS with or without stitch condensing	1112821
PEGASUS backlatch machine	1113234
PFAFF models 563, 953, 1050, 1180	1113746
PFAFF models 1245 & 335	1114003
SINGER models 211, 212U, 212UTT and 591	1112824
TYPICAL models 1245 & 335	1114003
UNION SPECIAL lockstitch machine model 63900AMZ (in replacement of US80A)	1112823
UNION SPECIAL model 34700 with stitch lock	1112844
UNION SPECIAL models 34000 and 36200 (in replacement of US80A)	1112865
UNION SPECIAL models CS100 and FS100	1112905
YAMATO VC/VG series chainstitch machines + stitch lock	1113345
YAMATO backlatch machine ABT3	1112826
YAMATO backlatch machine ABT13, ABT17	1113205
MAUSER models 1245 & 335	1114003
MITSUBISHI lockstitch machines <i>Connection of the position sensor incorporated in the hand wheel</i>	1113411

3 Putting into Service

Before putting the control into service, the following must be ensured, checked and/or adjusted:

- Selection of motor type using parameter **467**
- The correct installation of the drive, position transmitter and accompanying devices, if necessary
- The correct selection of the trimming operation using parameter **290**
- If necessary, the correct adjustment of the direction of motor rotation using parameter **161**
- The correct selection of the functions of keys (inputs) using parameters **240...246**
- The setting of the transmission ratio between motor shaft and machine shaft using parameter **272**
- The setting of the type of position sensor using parameter **270**
- If necessary, the adjustment of the positions using parameter **171**
if necessary, the setting of the positions using parameter **171** (possible with all settings of parameter **270**)
- The correct positioning speed using parameter **110**
- The correct maximum speed compatible with the sewing machine using parameter **111**
- The setting of the remaining relevant parameters
- Begin sewing in order to save the set values

4 Setting and Putting into Service with the Aid of the Fast Installation Routine (SIR)

Function with or without control panel	Parameters
Call-up of the Fast Installation Routine SIR	(Sir) 500

The Fast Installation Routine (SIR) passes through all parameters necessary for programming the functional sequence and the positions.

With SIR you can do the most important settings for initial operation with menu prompting. For safety reasons, the menu must be executed point by point. This ensures correct setting of all important parameters.

Input of the code number for the fitting level.



Parameter **500** is displayed.



Parameter **290** for functional sequence of the cutting procedures.



Parameter **467** for selection of motor.



Parameter **111** for the maximum speed.



Parameter **161** for direction of motor rotation.



Parameter **270** for type of position sensor.



Parameter **272** for transmission ratio.



Important! The transmission ratio should be determined and indicated as precisely as possible.

If parameter **270 = 0 or 5**, continue with input of **451**.
Check the transmission ratio.

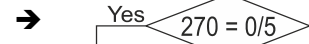

Move pedal forwards. Let the drive run until ready (rdy) is displayed.
Press pedal to position 0. The check is complete.



if parameter **270 = 6**, set the reference position.

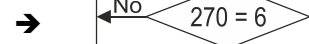

Turn hand wheel until symbol **o** display goes off.
Set reference position (e.g. height of the stitch plate, lower dead point).



Parameter **451** for position 1.



Parameter **453** for position 2.



To repeat the cycle from parameter **290**, push button **E**.

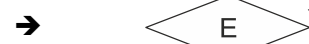

Or end with button **P** (2x).



The values can be varied by pressing key +/-.

The input of the code number is described in the general operating manual!

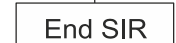

Setting on the operating part of the controls (onboard) or on V810:

1	Input code number 3112!		
2	Press the E key	→	Parameter 5.0.0. displayed
3	Press the E key	→	Sir displayed. The V810 displays the symbol [o] . Onboard: The 2 lower segments of the right 7 segment display flash.
4	Press the >> key	→	Parameter 2.9.0. appears (Functional cycle cutting processes)
5	Press the E key	→	Parameter value e.g. 05 appears.
6	Press the +/- key	→	The parameter value can be changed.
7	Press the E key	→	Parameter 4.6.7. appears Selection of motor; 1 =DC1500, 2 =DC1550, 3 =DC1200, 4 =DC1250)
8	Press the E key	→	Parameter value e.g. 3 appears.
9	Press the +/- key	→	The parameter value can be changed.
10	Press the E key	→	Parameter 1.1.1. appears (Maximum speed)
11	Press the E key	→	Value of the set speed appears.
12	Press the +/- key	→	The parameter value can be changed.
13	Press the E key	→	Parameter 1.6.1. appears (Direction of motor rotation)
14	Press the E key	→	Parameter value e.g. 1 appears.
15	Press the +/- key	→	The parameter value can be changed.
16	Press the E key	→	Parameter 2.7.0. appears (Type of position sensor)
17	Press the E key	→	Parameter value e.g. 0 appears.
18	Press the +/- key	→	The parameter value can be changed.
19	Press the E key	→	Parameter 2.7.2. appears (Transmission Ratio)
20	Press the E key	→	Parameter value e.g. 1000 appears.
21	Press the +/- key	→	The parameter value can be changed.
22			If parameter 270 =0 or 5 , or the check of the transmission ratio is already done, continue with Point 30.
23	Press the E key	→	PULY is displayed. (Check the transmission ratio)
24	Move pedal forwards		Let the drive run until ready (rdy) is displayed. For a maximum speed that is too high, an error message A12 is generated. Push button E as often as needed until parameter 111 (Point 12) is reached again to set the permitted maximum speed.
25	Press pedal to position 0 (neutral)		The check is complete.
26			When parameter 270 ≠ 6 , continue with Point 31.
27			P0 o (V810 PoS0 o) is displayed (o in red). (Setting the reference position)
28	Rotate the hand wheel in the running direction until o extinguishes *. Set reference position (e.g. height of the stitch plate, lower dead point).		
29	Press the E key	→	Parameter 4.5.1. appears (Position 1 leading edge, position 1 trailing edge is automatically set 60° higher)
30	Press the E key	→	Angle from position 1 is displayed.
31	Turn the hand wheel	→	Set position 1 (at least 1 rotation *).
32	Or press the +/- key	→	The parameter value can be changed.
33	Press the E key	→	Parameter 4.5.3. appears (Position 2 leading edge, position 2 trailing edge is automatically set 60° higher)
34	Press the E key	→	Angle from position 2 is displayed.
35	Turn the hand wheel	→	Set position 2 (at least 1 rotation *).
36	Or press the +/- key	→	The parameter value can be changed.
37	Upon pressing the E key once more the program returns to parameter 2.9.0.!		
38	Press the P key twice	→	The system exits the SIR routine.

*) All operations carried out by turning the hand wheel must always be carried out in the direction of rotation set up on the machine. Under no circumstances should you turn against the machine direction.

Setting on the V820 control panel:

1	Input code number 3112!		
2	Press the E key	→	Parameter 500 displayed.
3	Press the E key	→	Sir [o] displayed.
4	Press the >> key	→	Parameter 290 FAm 05 appears. (Functional cycle cutting processes)
5	Press the +/- key	→	The parameter value can be changed.
6	Press the E key	→	Parameter 467 MOT 3 appears. Selection of motor; 1 =DC1500, 2 =DC1550, 3 =DC1200, 4 =DC1250)
7	Press the +/- key	→	The parameter value can be changed.
8	Press the E key	→	Parameter 111 n2 appears. (Maximum speed)
9	Press the +/- key	→	The parameter value can be changed.
10	Press the E key	→	Parameter 161 drE 0 appears. (Direction of motor rotation)
11	Press the +/- key	→	The parameter value can be changed.
12	Press the E key	→	Parameter 270 PGM 0 appears. (Type of position sensor)
13	Press the +/- key	→	The parameter value can be changed.
14	Press the E key	→	Parameter 272 trr 01000 appears. (Transmission Ratio)
15	Press the +/- key	→	The parameter value can be changed.
16			If parameter 270 =0 or 5 , or the check of the transmission ratio is already done, continue with Point 25.
17	Press the E key	→	PULY Ab620A is displayed. Check the transmission ratio
18	Move pedal forwards		Let the drive run until ready (rdy) is displayed. For a maximum speed that is too high, an error message A12 is generated. Push button E as often as needed until parameter 111 (Point 12) is reached again to set the permitted maximum speed.
19	Press pedal to position 0 (neutral)		The check is complete.
20			When parameter 270 ≠ 6 , continue with Point 25.
21			PoS 0 o is displayed (o is red). (Setting the reference position)
22	Rotate the hand wheel in the running direction until o extinguishes *. Set reference position (e.g. height of the stitch plate, lower dead point).		
23	Press the E key	→	Parameter 451 P1E appears (Position 1 leading edge, position 1 trailing edge is automatically set 60° higher)
24	Turn the hand wheel	→	Set position 1 (at least 1 rotation *).
25	Or press the +/- key	→	The parameter value can be changed.
26	Press the E key	→	Parameter 453 P2E appears. (Position 2 leading edge, position 2 trailing edge is automatically set 60° higher)
27	Turn the hand wheel	→	Set position 2 (at least 1 rotation *).
28	Or press the +/- key	→	The parameter value can be changed.
29	Upon pressing the E key once more the program returns to parameter 290!		
30	Press the P key twice	→	The system exits the SIR routine.

*) All operations carried out by turning the hand wheel must always be carried out in the direction of rotation set up on the machine. Under no circumstances should you turn against the machine direction.

5 Quick access

These are button combinations that are linked in the direct access with settings & function of the control. Quick access can, however, can **only** be used with machines that are already set up.

5.1 Parameter back up

When the machine has been completely set up, the settings should be backed up.

5.1.1 Parameter backup



- Turning off the controls

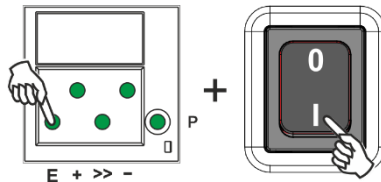

- Hold the E button down & turn on the controls
- (Hold down the E button 5 sec after turning on)

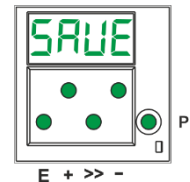

- "SAVE" is shown on the display

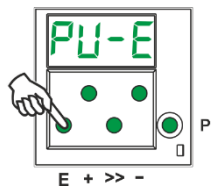

- Press the E button once, to execute the backup process

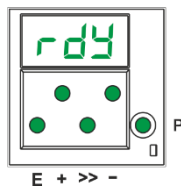

- When the process is completed, "rdy" is displayed for 1 second



- Turning off the controls

5.1.2 Restoring parameters from the backup



- Turning off the controls

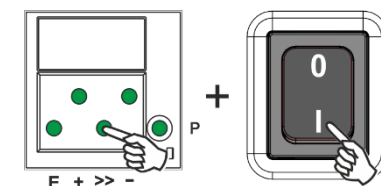

- >>-Hold the button down (5 sec) & turn on controls

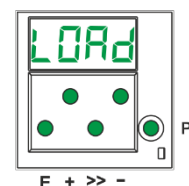

- "LOAD" is shown on the display

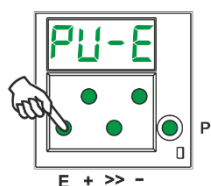

- Press the E button once, to execute the backup process

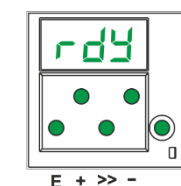

- When the process is completed, "rdy" is displayed for 1 second



- Turning off the controls

5.1.3 Save the parameter backup on a USB stick

(The parameters can be views with a text editor or Microsoft Word. The parameters in this file must **not** be changed!)

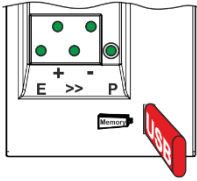

- Insert an empty USB Stick

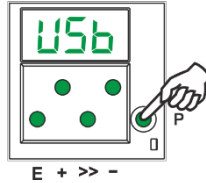

- Wait until "USB" shows on the display and press the P key
- Use the +/- buttons to get to parameter F-532. ("5.3.2" is shown on the display)

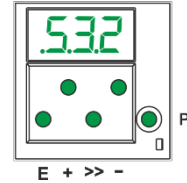

- Use the +/- buttons to get to parameter F-532. ("5.3.2" is shown on the display)

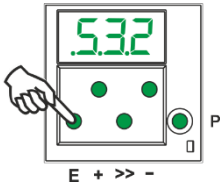

- Press the E button once

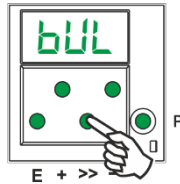

- Press the >> button

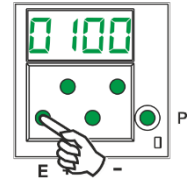

- Press the E button

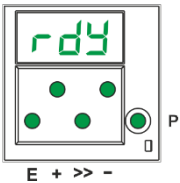

- When the process is completed, "rdy" is displayed for 1 second



- Turn off

5.1.4 Restoring the parameter backup from the USB stick

This process does not change the actual parameter settings. To load the backup to the current parameter setting, execute **Chapter 5.1.2 "Restoring parameters from backup"**. (After this process)

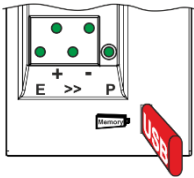

- Insert the USB stick with the file "0100DATA.PAB"

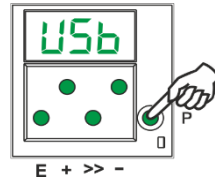

- Wait until "USB" shows on the display and press the P key
- Use the +/- buttons to get to parameter F-533. ("5.3.3" is shown on the display)

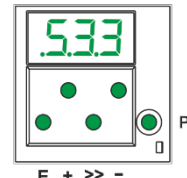

- Use the +/- buttons to get to parameter F-533. ("5.3.3" is shown on the display)

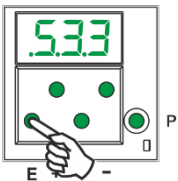

- Press the E button once

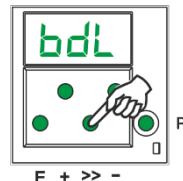

- Press the >> button

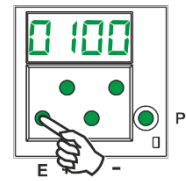

- Press the E button

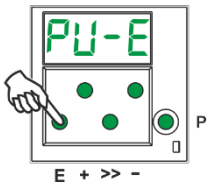

- Press the E button once, to execute the backup process

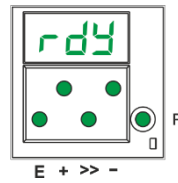

- When the process is completed, "rdy" is displayed for 1 second



- Turn off

5.2 Setting the reference position

(For detailed instructions refer to Chapter 6.9.1 Setting the Reference Position (Parameter 170))

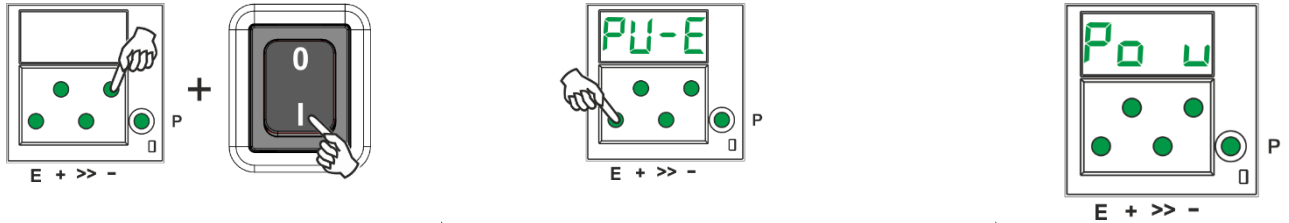

- Hold down the button and switch on the controls
- (Until Pos0 show for 1 second)



- Press the E button



- "P0" and a rotating "u" are displayed

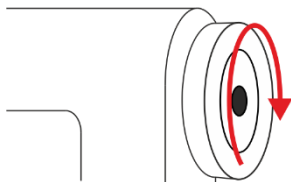

- Turn the handwheel until the rotating "u" disappears
- Bring the handwheel to the zero position (needle up / OT)

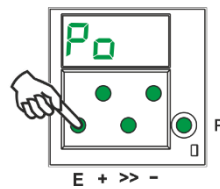

- Press the E button



- Turn off

Note: If the rotating "u" does not disappear after 10 rotations, change the direction of rotations.

6 Setting the Basic Functions

6.1 Direction of motor rotation

Function with or without control panel	Parameters	
Direction of motor rotation	(drE)	161

- 161 =0** Clockwise motor rotation (look at the motor shaft)
161 =1 Counterclockwise motor rotation



ATTENTION

If the motor is mounted differently, e. g. at a different angle or with gear, make sure that the value set using parameter **161** corresponds to the direction of rotation.

6.2 Use of a HSM001 Hall Sensor Module or IPG... Pulse Encoder

Representation and installation of a HSM001 Hall sensor module or IPG... pulse encoder !

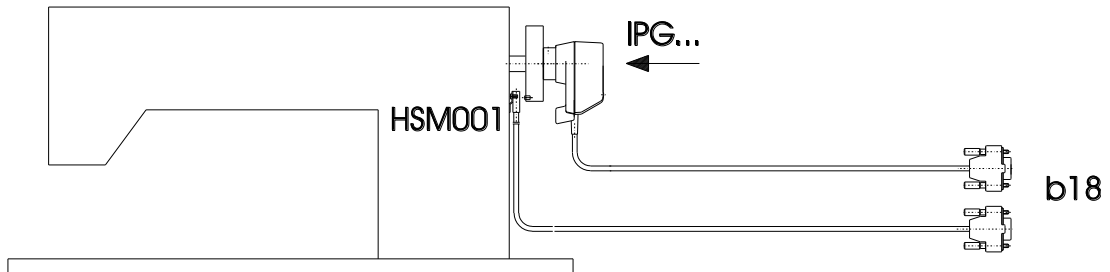

KL2521

Representation and installation of a HSM001 Hall sensor module or PG... pulse encoder together with a LSM002 light barrier module by means of adapter cord no. 1113229 !

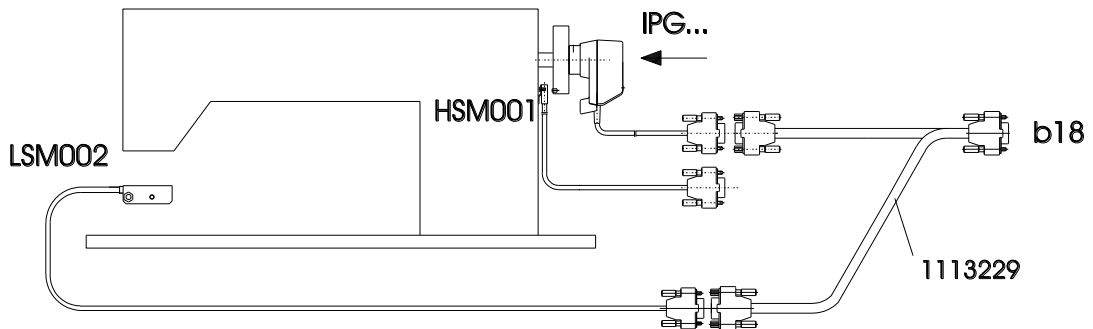

KL2522

Operation with HSM001 Hall sensor module

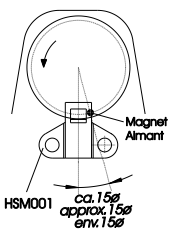

KL2523

- ← - Get machine to the needle-up position.
- Position bore for magnet such that the magnet is located approx. 15° after the sensor in the sense of rotation.
- Get machine to the needle-up position.
- Turn disk in the pulse encoder such that the leading edge will be located approx. 15° after the sensor on the board in the sense of rotation.

Operation with IPG... pulse encoder

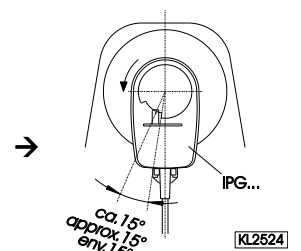

KL2524

6.3 Transmission Ratio

NOTE

The transmission ratio must always be input if no transmission ratio of 1:1 exists, because only motors with integrated incremental transmitters will be used. **The transmission ratio should be determined and set as precisely as possible!**

The transmission ratio between motor shaft and shaft of the sewing machine head must be input, so that the set speeds of parameters **110...117** correspond to the sewing speeds.

Function with or without control panel		Parameters
Transmission ratio between motor shaft and machine shaft	(trr)	272

The transmission ratio can be selected within a range of 150...40000 using parameter **272**.

Example: With a motor pulley diameter of 40 mm and a sewing machine head pulley diameter of 80 mm the value 500 can be calculated using the formula below. If the value 2000 has been selected in parameter 272, it follows that the motor pulley is double the size of the sewing machine head pulley.

$$\text{Value of parameter } 272 = \frac{\text{Motor pulley diameter}}{\text{Machine pulley diameter}} \times 1000$$

6.4 Selection of Functional Sequences (Thread Trimming Operations)

This drive is suitable for different lockstitch, chainstitch and overlock machines. The mode for the functional sequence required on the respective machine can be selected using parameter **290**.



ATTENTION

Before switching the functional sequences, you must disconnect input and output plug-and-socket connections between control and machine. Please ensure that the functional sequence (mode) suitable for the respective machine is selected.

Settings with parameter 290 are possible only after the power is turned On.

You will find a summary of the modes that can be set and the corresponding machines and adapter cords, to include available output signals in the List of Parameters chapter: Table of adapter cords.

Further information see chapter "Timing Diagrams" for the various modes.

6.5 Functions of the Keys Inputs in1...in7

The function that is started when a button or switch connected to one of the inputs in1 to in7 is actuated can be selected using parameters **240...246**.

The possible functions are listed in the section "Parameter list".

6.6 Positioning speed

Function with or without control panel		Parameters
Positioning speed	(n1)	110

The positioning speed can be set using parameter **110** on the control within a range of 70...390 RPM.

6.7 Maximum Speed Compatible with the Sewing Machine

The maximum speed of the machine is determined by the selected pulley and by the following settings:

- Set the maximum speed using parameter **111** (n2).
- Set the maximum speed limitation to the specific level according to the application as described in chapter "Direct Input of Maximum Speed Limitation (DED)".

6.8 Maximum speed

Function with or without control panel		Parameters
Maximum speed	(n2)	111

NOTE

See instruction manual of the sewing machine manufacturer for the maximum speed of the sewing machine.

NOTE

Select the pulley such that the motor runs at approx. 4000 RPM with max. number of stitches.

6.9 Positions

Function with or without control panel		Parameters
Mode for the position sensor	(PGm)	270
Setting the needle positions	(Sr2)	171
Transmission ratio between motor shaft and machine shaft	(trr)	272

A sensor can be used as a position sensor, e.g. Efka Hall sensor module (HSM1) or pulse generator (IPG) with either NC or NO functionality.

It is connected to socket B18/7.

Parameter **270** is used to select the mode to be selected depending on the type and mounting of the sensor used (see section Parameter List under parameter **270** for a description and flow chart).

After configuration of parameter **270** to "**1, 2, 3 o 4**", parameter **171** must be used to set the angle for positions 1 and/or 2, incoming and outgoing.

Alternatively, the positions can be configured using the fast-installation routine.

The transmission ratio must already have been input using parameter **272**.

6.9.1 Setting the reference position (Parameter 170)

The angular positions necessary on the machine e.g. “needle down position“ or “thread lever up position“ are stored in the control. A reference position is needed in order to establish a relationship between position transmitter information and actual mechanical position.

The reference position must be set:

- For initial operation
- After replacing the motor

Setting the reference position on the control

- Input code number and select parameter **170!**
 - Press the **E** key → Display **Sr1_**
 - Press the **>>** key → Display **P o u** (character “o” rotating) *1
 - Turn hand wheel until rotating character **o** goes off on the display. → Display **P o**
 - By turning the hand wheel, set the needle to the bottom dead center or the needle point to the height of the needle plate in the direction of rotation of the motor shaft, while needle is moving downward. → Configuration of the zero point of the machine
 - Press the **P** key once → Actual parameter number 170 is displayed *2
- or
- Press the **P** key twice → Exit programming at the technician level.

Setting the reference position on the V810 control panel

- Input code number and select parameter **170!**
 - Press the **E** key → Display **[o]**
 - Press the **>>** key → Display **P o u** (character o rotating) *1
 - Turn hand wheel until rotating character **o** goes off on the display. → Display **PoS 0**
 - Set the needle to the bottom dead center by turning the hand wheel. → Configuration of the zero point of the machine
 - Press the **P** key once → Actual parameter number 170 is displayed *2
- or
- Press the **P** key twice → Exit programming at the technician level.

Setting the reference position on the V820 control panel

- Input code number and select parameter **170!**
 - Press the **E** key → Display **F-170 Sr1 [o]**
 - Press the **>> F2** *3 → Display **P o u** (character o rotating) *1
 - Turn hand wheel until rotating character **o** goes off on the display. → Display **PoS 0**
 - Set the needle to the bottom dead center by turning the hand wheel. → Configuration of the zero point of the machine
 - Press the **P** key once → Actual parameter number 170 is displayed *2
- or
- Press the **P** key twice → Exit programming at the technician level.

*1) If **P 0** or **Pos 0** is displayed, the reference position is already set. To repeat the setting the power must be switched off and the code number reentered.

*2) The next parameter to be set can be selected.

*3) The button **>>(F2)** is the farthest button to the right on the control part.

If error message **A3** (reference position not set) appears, repeat the above setting sequence.

6.9.2 Setting the Positions

This is an explanation of terms for the following descriptions:

Position 1 means "Needle lower position"

Position 2 means "Thread lever up" or "Needle rod TDC"

Each position has a starting angle (start) and ending angle (end). The needle stop position always refers to the starting angle.

Position parameters		Parameters
Start position 1	(P1E)	451
End position 1	(P1A)	452
Start position 2	(P2E)	453
End position 2	(P2A)	454

The position window 1 and position window 2 must not overlap. Consider that the width of the position window is at least 30° (difference between start and end of the position)!

If positions are set via the Setting and Putting into Service with the Aid of the Fast Installation Routine (SIR), then only the starting angle must be set. The end angles are automatically set to 60° after the starting angle.

The needle positions should in principle only be set via the quick installation routine (SIR) to prevent erroneous inputs. You are guided through the required parameters with it.

See Section **Fehler! Verweisquelle konnte nicht gefunden werden**. Setting and Putting into Service with the Aid of the Fast Installation Routine (SIR)

It is only important to set the position window including end angle for specific cutting systems. For these systems, the cutting duration is controlled via the end angle of the position.

6.10 Display of the Signal and Stop Positions

Function with or without control panel		Parameters
Display of positions 1 and 2	(Sr3)	172

The position settings can easily be checked by means of parameter **172**.

- Select parameter **172**
- The control panel display shows "Sr3"
- Turn hand wheel according to the direction of motor rotation

Control display (control panel not connected)

- Segment **5** is turned on corresponds to position 1 On
- Segment **5** is turned off corresponds to position 1 Off
- Segment **6** is turned on corresponds to position 2 On
- Segment **6** is turned off corresponds to position 2 Off

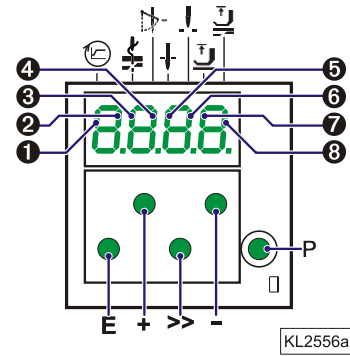

V810 / V820 control panel display

- Arrow above symbol "position 1" on key 4 (V810) / on key 7 (V820) is displayed corresponds to position 1 On
- Arrow above symbol "position 1" on key 4 (V810) / on key 7 (V820) is displayed corresponds to position 1 Off
- Arrow above symbol "position 2" on key 4 (V810) / on key 7 (V820) is displayed corresponds to position 2 On
- Arrow above symbol "position 2" on key 4 (V810) / on key 7 (V820) is displayed corresponds to position 2 Off

If the V810 or V820 control panel is connected, the positions will be displayed only on the control panel!

6.11 Positioning shift

Function with or without control panel	Parameters
Positioning shift	(PSv) 269

Determine by means of parameter **269** whether the drive is to stop exactly on the position (Parameter **269 =0**) or some increments after the position.

6.12 Braking Characteristics

Function with or without control panel	Parameters
Braking ramp running	(br1) 207
Braking ramp stop	(br2) 208
Braking ramp for $n < 350^{min^{-1}}/ms$ when drive stopped	(br3) 219

- Parameter **207** regulates the braking effect between speed stages
- Parameter **208** influences the braking effect for the stop
- Parameter **219** influences the braking effect before the stop

The following applies to all setting values: the higher the value, the stronger the braking reaction!

6.13 Braking Power at Standstill

Function with or without control panel	Parameters
Braking Power at Standstill	(brt) 153

This function prevents unintentional "wandering" of the needle at standstill. The effect can be checked by turning the hand wheel.

- The braking power is effective at standstill
 - at stop in the seam
 - after the seam end
- The effect can be set
- The higher the set value, the stronger the braking power

6.14 Starting Characteristics

Function with or without control panel		Parameters
Starting edge	(ALF)	220

The drive acceleration dynamics can be adapted to the sewing machine characteristic (light/heavy).

- High setting value = high acceleration

With a high starting edge setting and, in addition, possibly high braking parameter values on a light machine, the characteristic may appear coarse. In this case, one should try to optimize the settings.

6.15 Actual Speed Display

Function with control panel		Parameters
Display actual speed	(nIS)	139

If parameter **139 = 1**, the V810/V820 display shows the following information:

	V810	V820
During operation:		
▪ The actual speed	→ 2350	2350
▪ Example: 2350 revolutions per minute		
At stop in the seam:		
▪ The stop indication	→ StoP	StoP
At standstill after trimming:		
▪ On the V810, indication of the type of control		
▪ On the V820, indication of the set maximum speed and the type of control	→ Ab620A	4000 Ab620A
Example: 4000 revolutions per minute and type of control AB425S		

6.16 Operating hours counter

Function with or without control panel		Parameters
Acoustic signal (operating part)	(AkS)	127
Service routine for total operating hours	(Sr6)	176
Service routine for operating hours before service	(Sr7)	177
Input of operating hours before service	(Sr)	217

The integrated operating hours counter records the time of motor operation. Downtimes are not recorded. Time recording accuracy is 1ms. There are two ways of operating hours counting.

1. Basic operating hours counting:

217 =0 Operational mode: Operating hours counting

2. Service Hours Monitoring:

- 217 =>0** Operational mode: Number of operating hours before the next service.
 Input of operating hours before the next service.
 This value is compared to the operating hours counter.
 The input of hours is done in steps of 10. i. e. the lowest display of 001 corresponds to 10 hours (e. g. 055 = 550 hours).
 When the set number of operating hours are reached, the message "C1" will show on the display after each trimming operation. In addition, the speed indicator blinks on the control or on the V820 control panel during operation or after drive standstill.
 Moreover, an acoustic signal is emitted when using a V810/V820 control panel if parameter **127=1**.
- 176** In this service routine, the total operating hours can be read out according to the procedure example described below for parameter **177**.
- 177** Display of operating hours since the **last** service.

Display example of operating hours or hours since the last service and operating hours counter reset.

Display on the control:

- Select parameter **177**
- Press the **E** key → **Sr7**
- Press the **>>** key → **h t** (hours /thousands letter symbol)
- Press the **E** key → **000** (hours /thousands display)
- Press the **E** key → **h h** (hours / hundreds letter symbol)
- Press the **E** key → **000** (hours / hundreds display)
- Press the **E** key → **Min** (minutes letter symbol)
- Press the **E** key → **00** (minutes display)
- Press the **E** key → **SEc** (seconds letter symbol)
- Press the **E** key → **00** (seconds display)
- Press the **E** key → **MS** (milliseconds letter symbol)
- Press the **E** key → **000** (milliseconds display)
- Press the **E** key → **rES** See chapter "Set and Reset Operating Hours Counter"
- Press the **E** key → The process will be repeated from the hours display.
- Press the **P** key twice → e.g. **400** (sewing process can be started)

Display on the V810 control panel:

- Select parameter **177**
- Press the **E** key → **Sr7 [°]**
- Press the **>>** key → **hoUr** (hours letter symbol)
- Press the **E** key → **000000** (hours display)
- Press the **E** key → **Min** (minutes letter symbol)
- Press the **E** key → **00** (minutes display)
- Press the **E** key → **SEc** (seconds letter symbol)
- Press the **E** key → **00** (seconds display)
- Press the **E** key → **MSEc** (milliseconds letter symbol)
- Press the **E** key → **000** (milliseconds display)
- Press the **E** key → **rES F2** See chapter "Set and Reset Operating Hours Counter"
- Press the **E** key → The process will be repeated from the hours display.
- Press the **P** key twice → e.g. **Ab620A** (sewing process can be started)

Display on the V820 control panel:

- Select parameter **177**
- Press the **E** key → **F-177** **Sr7 [°]**
- Press the **>>** key → **hoUr** **000000** (hours display)
- Press the **E** key → **Min** **00** (minutes display)
- Press the **E** key → **Sec** **00** (seconds display)
- Press the **E** key → **MSEc** **000** (milliseconds display)
- Press the **E** key → **rES** **F2** See chapter "Set and Reset Operating Hours Counter"
- Press the **P** key twice → e.g. **4000** **Ab620A** (sewing process can be started)

6.16.1 Set and Reset Operating Hours Counter

The number of hours has been reached (service necessary):

- Press the >> key once → The operating hours counter is set to "0" and restarted.

The number of hours has not yet been reached:

- Press the >> key three times → The operating hours counter is set also to "0" and restarted.

A value in parameter 177 has been changed:

- After displaying rES ..., when the E key is pressed again, SEt will then be displayed.
- If the changed value is to be saved, press the >> key 3 times.

6.16.2 Total Operating Hours Display

In this service routine enabled using parameter 176, the total number of operating hours is displayed.

The sequence of displayed values is as with parameter 177.

The values can only be displayed, not varied. Therefore, letter symbols "rES" for "reset" and "SEt" for "set" will not appear.

7 Functions with or without Control Panel

7.1 First Stitch after Power On

Function with or without control panel	Parameters
1 stitch at positioning speed after power On (Sn1)	231

If parameter 231 is on, the first stitch after power on will be performed at positioning speed for the protection of the sewing machine. This is independent of the pedal position and the softstart function.

7.2 Softstart

Function with or without control panel	Parameters
Softstart On/Off (SSt)	134

Functions:

- After power on
- At the beginning of a new seam
- Speed pedal controlled and limited to (n6)
- Lower speed of a parallel function prevailing (e. G. Stitch count)
- Stitch counting synchronized to position 1
- Suspension with pedal in position 0 (neutral)
- Interruption by full heelback (position -2)

When using the V820 control panel, direct access by means of the function key (key 9) is possible!

Function with control panel	Parameters
Softstart On/Off (-F-)	008 =1

7.2.1 Softstart speed

Function with or without control panel	Parameters
Softstart speed (n6)	115

7.2.2 Softstart stitches

Function with or without control panel		Parameters
Number of softstart stitches	(SSc)	100

7.3 Sewing foot lifting

Function without control panel		Control
Automatic in the seam	Segment 7 on	Key – (S4)
Automatic after thread trimming	Segment 8 on	

Function with control panel		V810	V820
Automatic in the seam	Left-hand arrow above key On	Key 3	Key 6
Automatic after thread trimming	Right-hand arrow above key On	Key 3	Key 6
If parameter 290 = 16, with slide-in strip "7"	Left-hand arrow above key On		Key 9

Function		Parameters
Automatic sewing foot with pedal forward at the seam end if light barrier or stitch counting is On	(AFL)	023
Coupled thread tension release and sewing foot lifting. The function can be activated only with a thread trimmer that depends on the angle.	(FSP)	024
Switch-on delay with pedal in position –1	(t2)	201
Start delay after disabling the sewing foot lifting signal	(t3)	202
Time of full power of sewing foot lifting	(t4)	203
Duty ratio (ED) with pulsing	(t5)	204
Delay after thread wiping until sewing foot lifting	(t7)	206
Delay after thread trimming without thread wiper until sewing foot lifting	(tFL)	211
Upper limit ON period of sewing foot lifting 1...100	(EF-)	254

Sewing foot is lifted:

- in the seam
 - by heelback (position -1)
 - or automatically (using the - S4 key on the control, segment 7 lights up)
 - or automatically (using key **3** on the V810 control panel)
 - or automatically (using key **6** on the V820 control panel)
 - by pressing a key depending on the pre-selection of parameters **240...246**
- after thread trimming
 - by heelback (position -1 or -2)
 - or automatically (using the - S4 key on the control, segment 8 lights up)
 - or automatically (using key **3** on the V810 control panel)
 - or automatically (using key **6** on the V820 control panel)
 - by pressing a key depending on the pre-selection of parameters **240...246**
 - automatically by light barrier when pedal forwards, according to the setting of parameter **023**
 - automatically by stitch counting when pedal forwards, according to the setting of parameter **023**
 - Switch-on delay after thread wiper (t7)
 - Switch-on delay without thread wiper (tFL)

It is possible to prevent unintentional foot lifting before thread trimming when changing from pedal position 0 (neutral) to position -2 by setting a switch-on delay (t2) using parameter **201**.

Holding power of the lifted foot:

The sewing foot is lifted by full power. Then the system switches automatically to partial power in order to reduce the load for the control and the connected solenoid.
Set the duration of full power using parameter **203** and the partial holding power using parameter **204**.



ATTENTION

If the holding power is set too high, the solenoid and the control may be permanently damaged. Please observe the permissible duty ratio (ED) of the solenoid and set the appropriate value according to the table below.

Value	Duty ratio (ED)	Effect
1	1 %	Low holding power
100	100 %	High holding power (full power)

Sewing foot lowers:

- Press pedal to position 0 (neutral)
- Press pedal to position ½ (slightly forward)
- Release key for manual sewing foot lifting

Upon pressing the pedal forward from lifted sewing foot, the start delay (t3) that can be set using parameter **202** becomes effective.

7.4 Start Backtack/Start Stitch Condensing

Function without control panel		Control
Single start backtack Double start backtack Start backtack Off	Segment 1 on Segment 2 on Both segments off	Key E (S2)
Start stitch condensing On; number of stitches with stitch regulator (Parameter 001) Start stitch condensing On; number of stitches without stitch regulator (Parameter 000) after that number of stitches with stitch regulator (Parameter 001) Start stitch condensing Off	Segment 1 on Segment 2 on Both segments off	Key E (S2)

Function with control panel		V810/V820
Single start backtack Double start backtack Start backtack Off	Left-hand arrow above key On Right-hand arrow above key On Both arrows Off	Key 1
Start stitch condensing On; number of stitches with stitch regulator (Parameter 001) Start stitch condensing On; number of stitches without stitch regulator (Parameter 000) after that number of stitches with stitch regulator (Parameter 001) Start stitch condensing Off	Left-hand arrow above key On, right-hand arrow above key On Both arrows Off	Key 1

The start backtack/start stitch condensing starts by pressing the pedal forward at the beginning of the seam. From lifted sewing foot the backtack is delayed by the time t3 (start delay after switching off the sewing foot lifting signal). Start backtack as well as start stitch condensing are executed automatically at speed n3. They cannot be interrupted. If softstart is running parallel, the respective lower speed is prevailing. The stitch regulator will be switched off after completion of the stitch count (Parameter **001**) and the speed n3 after a delay time t1. Then pedal control is returned. The stitch regulator and counter are synchronized to position 1.

7.4.1 Speed n3 at the Start of the Seam

Function with or without control panel		Parameters
Start backtack/start stitch condensing speed	(n3)	112
Start backtack/start stitch condensing speed can be interrupted by pedal in pos. 0 (neutral)	(n2A) (StP)	162 164
Start and end backtack or stitch condensing can be interrupted by pedal in pos. 0 (neutral) On/Off		

7.4.2 Stitch Counting for Start Backtack/Start Stitch Condensing

Function with or without control panel		Parameters
Number of stitches forward or without stitch regulator	(c2)	000
Number of stitches backward or with stitch regulator	(c1)	001
Double start backtack repetition	(war)	090
Backtack repetition On/Off	(Fwr)	092

The start backtack/start stitch condensing stitches with or without stitch regulator can be programmed and varied using the above parameters directly on the control or on a connected V810/V820 control panel.

For fast operator information (HIT) when using the V820 control panel, the value of the function switched on using key **1** can be displayed for approx. 3 seconds. During this time, the value can be varied directly by pressing key **+** or **-**.

7.4.3 Stitch Correction and Speed Release

Function with or without control panel		Parameters
Stitch correction time	(t8)	150
Delay until speed release after start backtack	(t1)	200

Speed release after single and double backtack can be influenced by parameter **200**.

In the case of slow backtack mechanisms it is possible to delay disabling of the stitch regulator in the single and double start backtack by the time t8 (start backtack stitch correction) and thereby prolong the backward section. This time-lag can be selected by means of parameter **150**.

7.4.4 Double start backtack

The forward section will be sewn for a number of stitches that can be set. Then the stitch regulator signal will be issued and the backward section will be executed. The number of stitches for the two sections can be set separately.

7.4.5 Single Start Backtack / Start Stitch Condensing

The stitch regulator signal will be issued and the backward section and/or start stitch condensing will be executed for a number of stitches that can be set.

7.5 End Backtack / End Stitch Condensing

Function without control panel		Control
Single end backtack Double end backtack End backtack Off	Segment 3 on Segment 4 on Both segments off	Key + (S3)
End stitch condensing On; number of stitches with stitch regulator (Parameter 002) End stitch condensing on; stitch count with stitch regulator (Parameter 002), afterwards the stitch count without the stitch regulator (Parameter 003). End stitch condensing Off	Segment 3 on Segment 4 on Both segments off	Key + (S3)

Function with control panel		V810	V820
Single end backtack Double end backtack End backtack Off	Left-hand arrow above key On, right-hand arrow above key On Both arrows Off	Key 2	Key 4
End stitch condensing On; number of stitches with stitch regulator (Parameter 002) End stitch condensing on; stitch count with stitch regulator (Parameter 002), afterwards the stitch count without the stitch regulator (Parameter 003). End stitch condensing Off	Left-hand arrow above key On, right-hand arrow above key On Both arrows Off	Key 2	Key 4

The end backtack/end stitch condensing in a seam with stitch counting starts by heelback at the end of counting, or, from the light barrier seam at the end of the light barrier compensating stitches. The stitch regulator is immediately enabled from machine standstill. After lowering the sewing foot, the switch-on point of the stitch regulator is delayed by the time t3 (start delay after switching off the sewing foot lifting signal). The first leading edge of position 1 counts as 0 stitch whenever the function is not started in position 1. The stitch regulator is synchronized to position 1. End backtack as well as end stitch condensing are executed automatically at speed n4. They cannot be interrupted. From full machine run, end backtack / end stitch condensing will be switched in only after having reached the speed n4 and synchronization to position 2.

7.5.1 Speed n4 at the Seam End

Function with or without control panel		Parameters
End backtack/end stitch condensing speed	(n4)	113
End backtack/end stitch condensing speed can be interrupted by pedal in pos. 0 (neutral)	(n2E) (StP)	163 164
Start and end backtack or stitch condensing can be interrupted by pedal in pos. 0 (neutral) On/Off		

7.5.2 Stitch Counting for End Backtack/End Stitch Condensing

Function with or without control panel		Parameters
Number of stitches forward or without stitch regulator	(c3)	002
Number of stitches backward or with stitch regulator	(c4)	003
Double end backtack repetition	(wer)	091
Backtack repetition On/Off	(Fwr)	092

The end backtack/end stitch condensing stitches with or without stitch regulator can be programmed and varied using the above parameters directly on the control or on a connected V810/V820 control panel.

For fast operator information (HIT) when using the V820 control panel, the value of the function switched on using key **4** can be displayed for approx. 3 seconds. During this time, the value can be varied directly by pressing key **+** or **-**.

7.5.3 Stitch Correction and Last Stitch Backward

Function with or without control panel		Parameters
Last stitch backward On/Off	(FAr)	136
Stitch correction time	(t9)	151

The backtack solenoid can be delayed in the double end backtack by selecting a stitch correction time (t9) using parameter **151**.

For some sewing procedures it is desirable that the backtack solenoid in the single end backtack is disabled only after trimming. This function can be selected using parameter **136**.

136 =0 Trimming stitch backward Off

136 =1 Trimming stitch backward On with single end backtack

136 =2 Trimming stitch or positioning stitch always backward at the seam end

7.5.4 Double End Backtack/End Stitch Condensing

The backward section and/or end stitch condensing will be executed for a number of stitches that can be set. Then the stitch regulator will be disabled and the forward section and/or normal stitch condensing stitches will be executed. The number of stitches for the two sections can be set separately.

After stitch counting (Parameter **003**) the trimming function will be initiated. During the entire operation the sewing speed is reduced to speed n4, with the exception of the last stitch, which will be performed at positioning speed n1.

In the case of slow backtack mechanisms it is possible to delay disabling of the stitch regulator in the single and double end backtack by the time t9 (end backtack stitch correction).

7.5.5 Single End Backtack / End Stitch Condensing

The stitch regulator signal will be issued and the backward section and/or end stitch condensing will be executed for a number of stitches that can be set. During the last stitch the speed is reduced to positioning speed.

When using the V820 control panel, direct access by means of the function key (key 9) is possible!

Function with control panel		Parameters
Backtack repetition On/Off	(-F-)	008 =8

7.5.6 Backtack Synchronization

Function with or without control panel		Parameters
Backtack synchronization for start and end backtack On/Off	(nSo)	298
Backtack synchronization speed	(nrS)	299

If parameter **298** is on, the backtack speed will be switched to backtack synchronization speed one stitch before engaging and disengaging of the backtack solenoid. After the switch on and off the locking magnets, during the next position 2 the lock speed is released again. If the synchronization speed, adjustable with parameter **299**, is higher than the locking speed, the locking speed is retained. Backtack synchronization is possible in the start and end backtack.

7.6 Start Ornamental Backtack/Stitch Condensing

Function without control panel		Control
Function "ornamental backtack" On/Off	(SrS)	135
Ornamental backtack stop time	(tSr)	210
Single start ornamental backtack	Segment 1 on	key E (S2)
Double start ornamental backtack	Segment 2 on	
Start ornamental backtack Off	Both segments off	

Function with control panel		V810/V820
Function "ornamental backtack" On/Off	(SrS)	135
Ornamental backtack stop time	(tSr)	210
Single start ornamental backtack	Left-hand arrow above key On	Key 1
Double start ornamental backtack	Right-hand arrow above key On	
Start ornamental backtack Off	Both arrows Off	

The parameters of the start backtack speed and the backtack stitches forward and backward are identical with the standard start backtack.

Difference from the standard start backtack:

- The drive stops for stitch regulator switching
- The stop time can be set

When using the V820 control panel, direct access by means of the function key (key 9) is possible!

Function with control panel		Parameters
Ornamental backtack On/Off	(-F-)	008 =2

7.7 End Ornamental Backtack/Stitch Condensing

Function without control panel		Control
Function "ornamental backtack" On/Off	(SrS)	135
Ornamental backtack stop time	(tSr)	210
Single end backtack	Segment 3 on	Key + (S3)
Double end backtack	Segment 4 on	
End backtack Off	Both segments off	

Function with control panel		V810	V820
Function "ornamental backtack" On/Off	(SrS)	135	135
Ornamental backtack stop time	(tSr)	210	210
Single end backtack	Left-hand arrow above	Key 2	Key 4
Double end backtack	key On, right-hand arrow		
End backtack Off	above key On		
	Both arrows Off		

The parameters of the end backtack speed and the backtack stitches forward / backward are identical with the standard end backtack.

Difference from the standard end backtack:

- The drive stops for stitch regulator switching
- The stop time can be set

When using the V820 control panel, direct access by means of the function key (key 9) is possible!

Function with control panel		Parameters
Ornamental backtack On/Off	(-F-)	008 =2

7.8 Intermediate Backtack

Upon pressing an external key according to the pre-selection of parameters **240...246**, the backtack solenoid can be switched on anywhere in the seam and at standstill.

Function with or without control panel		Parameters
Counted manual backtack On/Off	(chr)	087
Speed of manual backtack	(n13)	109
Ornamental backtack On/Off	(SrS)	135
Manual ornamental backtack speed	(n9)	122
Speed status for manual backtack	(Shv)	145

The speed function for the manual backtack can be set using parameter **145**.

145 =0 Speed controllable by the pedal up to the set maximum speed (Parameter **111**)

145 =1 Fixed speed (Parameter **109**) without influence by the pedal (machine stop by pressing the pedal to the basic position)

145 =2 Limited speed controllable by the pedal up to the set limit (Parameter **109**)

Intermediate backtack (Parameter **135 = 0**):

Backward sewing with speed limitation according to the setting of parameter 109 is performed when the key is held down.

Intermediate ornamental backtack (Parameter **135 = 1**):

By pressing the key in the seam, the drive stops and the backtack solenoid is activated. The speed limitation n9 according to the setting of parameter 122 is effective during the entire intermediate backtack operation. Backward sewing is performed when the key is held down and the stitches are counted. When the key is released, the drive stops, the backtack solenoid is switched off and a forward seam is performed according to the counted stitches after the ornamental backtack stop time. After that the speed limitation is released.

Moreover, the number of stitches for each type of backtack can be selected using Parameter **087**.

087 = 0 Stitches Normal manual backtack

087 = 1...255 Stitches Manual backtack with counted backtack

Intermediate backtack (Parameter **135 = 0**) with counted backtack section (Parameter **087 = >0**):

During manual backtack the speed is n13 (Parameter 109). According to the setting of parameter 145 it is pedal controlled, fixed or limited.

Intermediate ornamental backtack (Parameter **135 = 1**) with counted backtack section (Parameter **087 = >0**):

After the button is pushed, the drive stops in position 1. The locking magnet is switched on. After the ornamental backtack stop time (Parameter 210) has elapsed and the pedal has been pressed forward, the drive runs until counting (Parameter 087) has been completed. The drive stops again in position 1. The backtack solenoid is disabled, and the time set using parameter 210 elapses. Then the seam section forward is repeated. The sequence is performed at speed n9 (Parameter 122).

7.9 Stitch Regulator Suppression/Recall

Effective in standard and ornamental backtack

The next backtack and/or stitch condensing operation can be suppressed or recalled once by pressing an external key according to the pre-selection of parameters **240...246**.

Upon pressing the key,	Start Backtack/ Stitch condensing On	Start Backtack/ Stitch condensing Off	End backtack / Stitch condensing On	End Backtack/ Stitch condensing Off
Before the start of the seam	No backtack / Stitch condensing	Backtack/ Stitch Condensing	-----	-----
In the seam	-----	-----	No backtack / Stitch condensing	Backtack/ Stitch Condensing

The double backtack is performed in the above cases.

7.10 Holding Power of the Stitch Regulator Solenoid

Function with or without control panel		Parameters
Time of full power	(t10)	212
Holding Power of the Stitch Regulator Solenoid	(t11)	213
Upper limit stitch regulator ON period	(EV-)	255

The stitch regulator solenoid is engaged by full power. Then the system switches automatically to partial power in order to reduce the load for the control and the connected stitch regulator solenoid. Set the duration of full power using parameter **212** and the partial holding power using parameter **213**.



ATTENTION

If the holding power is set too high, the solenoid and the control may be permanently damaged. Please observe the permissible duty ratio (ED) of the solenoid and set the appropriate value according to the table below.

Value	Duty ratio (ED)	Effect
1	1 %	Low holding power
100	100 %	High holding power (full power)

7.11 Reverse motor rotation

Function with or without control panel		Parameters
Positioning speed	(n1)	110
Reversing angle	(ird)	180
Switch-on delay of reverse motor rotation	(drd)	181
Reverse motor rotation On/Off	(Frd)	182

The function "reverse motor rotation" is performed after trimming. When the stop position is reached, the drive stops for the duration of the switch-on delay of reverse motor rotation. Then it runs in reverse direction at positioning speed according to the set degrees.

7.12 Unlocking the Chain (Mode 5/6/7)

Function with or without control panel		Parameters
Number of run-out stitches when unlocking the chain	(c6)	184
Function "unlock the chain" in modes 5, 6 and 7	(mEk)	190

Upon unlocking the chain at the seam end, the functions **thread trimming** and tape cutter/fast scissors are automatically suppressed. When setting parameter **190 = 3**, the function **tape cutter/fast scissors** is however possible. After pressing the key "unlocking the chain" and with pedal in position 0 (neutral), the drive always stops in position 1.

Settings necessary for the operation "unlocking the chain":

- Set "unlock the chain" using parameter **190 =1 / 2 / 3 / 4** (**190 =0** "unlock the chain" off)
- Set **switch-on delay** using parameter **181** and **reversing angle** using parameter **180**
- Determine the **function of the key "unlock the chain"** using one of the parameters **240...246**
- If parameter **290** is set at"

190 =0 Unchaining switched off

190 =1 Sequence with pedal in position -2 from machine run or from position 2:

- Press key "unlock the chain"
- Run at positioning speed to position 1
- Sequence of reversing angle at positioning speed after a switch-on delay that can be set

190 =1 Sequence with pedal in position -2 from standstill in position 1:

- Press key "unlock the chain"
- Run at positioning speed to position 1
- Sequence of reversing angle at positioning speed after a switch-on delay that can be set

190 =2 Automatic sequence with light barrier at the seam end without tape cutting / pedal in position -2 according to the setting of parameter 019

- Press key "unlock the chain"
- Run to position 1 after light barrier sensing
- Sequence of reversing angle at positioning speed after a switch-on delay that can be set

190 =3 Automatic sequence with light barrier on the seam end with tape cutter and run-out stitches(Only possible in mode 7 and if parameter 018 =0)

- Press key "unlock the chain"
- After light barrier detection, sequence of the compensation stitches and end count up to tape cutting
- Run-out stitches up to unlocking the chain, adjustable with parameter 184
- Sequence of reversing angle at positioning speed after a switch-on delay that can be set

190 =4 Sequence with pedal in position -2 / no unlocking of the chain if seam end with light barrier, cutting and run-out stitches is set:

- Press the pedal to position -2
- Run at positioning speed to position 1
- Sequence of reversing angle at positioning speed after a switch-on delay that can be set
- No unlocking of the chain at the seam end with light barrier
- Reverse motor rotation is suppressed when the drive stops. The signals "blow fabric onto stack", M2 and "sewing foot lift" will be issued.

When using the V820 control panel, direct access by means of the function key (key 9) is possible!

Function with control panel		Parameters
Unlocking the chain On/Off	(-F-)	008 =4

7.13 Machine run blockage

	<p>ATTENTION</p> <p>This is not a safety function. The line voltage must still be switched off during maintenance and repair work.</p>
---	---

The function “machine run blockage” is enabled by connecting a switch to socket ST2, depending on the pre-selection of parameters 240...246. When using a V810 / V820 /control panel, an acoustic signal can be switched on and/or off by means of parameter 127.

Display after enabling machine run blockage without control panel:

Control display

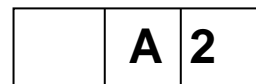

Display and signal after enabling machine run blockage with control panel:

Display on the V810 control panel!



(symbol blinks and acoustic signal if parameter 127 = 1)



Display on the V820 control panel!

(symbol blinks and acoustic signal if parameter 127 = 1) →



Machine run blockage in the free seam, seam with stitch counting and light barrier seam:

The seam is suspended by opening and/or closing the switch.

- Stop in the basic position
- Needle up is not possible
- Sewing foot lifting is possible

Machine run blockage in the start backtack / start stitch condensing:

The start backtack / start stitch condensing is interrupted by opening and/or closing the switch.

- Stop in the basic position
- Needle up is not possible
- Sewing foot lifting is possible
- After disabling of the machine run blockage, the seam will be continued with the section following the start backtack / start stitch condensing

Machine run blockage in the end backtack / end stitch condensing:

The end backtack / end stitch condensing is interrupted, and the seam is completed by opening and/or closing the switch.

- Sewing foot lifting is possible

7.14 High lift for walking foot / flip-flop 1

Function with or without control panel		Parameters
High lift for walking foot On/Off	(hP)	137
Signal “high lift for walking foot” when key is closed/open	(ihP)	263

High lift for walking foot is effective only if input function 13 or 14 has been selected using one of the parameters **240...246** and parameter **137 =1**. Select using parameter **263** whether the key is to be active when open or when closed.

263 =0 Signal “high lift for walking foot” is issued when key is closed

263 =1 Signal “high lift for walking foot” is issued when key is opened

7.14.1 High lift walking speed

Function with or without control panel		Parameters
High lift walking speed	(n10)	117

7.14.2 High Lift Walking Speed Run-Out Time

Function with or without control panel	Parameters
High Lift Walking Speed Run-Out Time (thP)	152

7.14.3 High Lift Walking Stitches

Function with or without control panel	Parameters
Number of high lift walking stitches (chP)	185

Upon pressing the external key "high lift for walking foot" depending on the setting of parameters **240...246**, the speed is limited to high lift walking speed. The solenoid for high lift for walking foot is switched on if the speed \leq high lift walking speed. It is possible to program run-out stitches using parameter **185**. This way, high lift for walking foot remains on until stitch counting has been completed. The speed limitation remains effective during run-out time after the solenoid for high lift for walking foot has been switched off.

7.14.4 High Lift for Walking Foot Operational Mode Not Stored (Parameters 240...246 = 13)

The following function is performed if "0" run-out stitches have been programmed using parameter **185**:

- Press the key "high lift for walking foot"; signal "high lift for walking foot" is On.
- Release the key "high lift for walking foot"; signal "high lift for walking foot" turns off.

The following function is performed if ">0" run-out stitches have been programmed using parameter **185**:

- When pushing the "high lift foot for walking" key for the first time at a drive stand still: The "high lift foot for walking" switches on and remains on after the button is released.
- When pressing the "high lift foot for walking" key again at drive standstill: The "high lift foot for walking" signal switches off again.

If the signal "high lift for walking foot" is On when starting the drive, the speed will be limited. The signal turns off after the run-out stitches have been executed, and the speed limitation will be disabled after the run-out time (Parameter **152**). If the key is held down until after counting, high lift for walking foot remains On. If the key is pressed only briefly, counting takes priority.

While the drive is running, if ">0" run-out stitches have been programmed using parameter **185**:

- Pushing the "high lift foot for walking" key while the drive is running: The "high lift foot for walking" signal and "high lift foot for walking" speed switch on.
- Release the "high lift foot for walking" key while the drive is running: The signal "high lift foot for walking" switches off and depending on the run-out time (Parameter **152**) the speed limit is disabled again.

7.14.5 High Lift for Walking Foot Operational Mode Stored /Flip-Flop 1 (Parameters 240...246 = 14)

- Upon first actuation of the "high lift foot for walking" key while the drive is running: The "high lift foot for walking" signal and "high lift foot for walking" speed switch on.
- By repeatedly pushing the "high lift foot for walking" key while the drive is running: Signal "high lift foot for walking" switches off immediately and after the run-out time (Parameter **152**), speed limiting is released.

7.15 Speed Limitation Depending on High Lift

Function with or without control panel	Parameters
Maximum speed (n2)	111
High lift walking speed (n10)	117
Lift-dependent speed limiting with potentiometer on (Pot)	126 =7
High lift for walking foot - measurement value of potentiometer for minimum lift	911
High lift for walking foot - measurement value of potentiometer for maximum lift	912

The lift-dependent speed limitation depends on the position of the adjustment wheel for the lift, which is coupled with a potentiometer. It may be activated or deactivated using parameter **126**.

126 =0 Deactivated. The maximum speed n10 set with parameter **117** is in effect.

126 =7 Activated. The speed is limited to a value that depends on the lift level configured.

The speed is limited in the range between the maximum speed (n2, parameter **111**) for the minimum height, and a high lift walking speed (n10, parameter **117**) for the maximum lift.

7.15.1 Programming the measurement value of the poti

- Call parameter **911**.
- Turn the adjustment wheel for the lift until the value displayed changes.
- Then set the **minimum** height lift.
- Confirm the change with the **E** button

- Call parameter **912**.
- Turn the adjustment wheel for the lift until the value displayed changes.
- Then set the **maximal** height lift.
- Confirm the change with the **E** button

- Call parameter **401**.
- Set a value of **1** to save the changes. Storage by pressing the **P** button twice with subsequent approximation is not possible here

NOTE

If the values are outside the permitted range, fault message **A11** will be emitted.

7.16 Speed Limitation n9

Function with or without control panel	Parameters
Speed Limitation n9	(n9) 122

When a key is pushed to which input function **33** is assigned, speed limitation n9 is activated. The speed is controlled by the pedal up to the limit.

7.17 Thread trimming operation

Function	Parameters
Thread trimmer On/Off	FA 013
Thread wiper On/Off	FW 014

Function with control panel	Parameters
Thread trimmer or thread wiper On/Off	V820 Key 5

When a V820 control panel is connected, the functions can also be switched on and off using key 5.

7.17.1 Thread Trimmer/Thread Wiper (Lockstitch Modes)

Function		Parameters
Thread wiper time	(t6)	205
Thread wiper switch-on delay	(dFw)	209
Holding power output M1 of the thread trimmer backward	(t11)	213
Thread trimmer activation angle	(iFA)	250
Switch-off delay of thread tension release	FSA	251
Thread tension release switch-on delay	FSE	252
Stop time for thread trimmer	(tFA)	253
Upper limit ON period of thread trimmer backward	EV-	255
Switch-on delay angle of the thread trimmer	FAE	259

Thread trimming in the lockstitch modes is performed at trimming speed.

When the thread trimmer is off, the drive stops in position 2 at the seam end; it stops in position 1 at the end of programmed seams.

The thread wiper ON period can be set depending on the selected trimming mode (see chapter "Timing Diagrams" in the List of Parameters). The delay time (t7) (Parameter **206**) prevents sewing foot lifting before the thread wiper is in its initial position.

If the thread wiper is not connected, there will be a delay time (tFL) after thread trimming until sewing foot lifting.

7.17.2 Trimming speed

Function		Parameters
Trimming speed	(n7)	116

7.17.3 Chainstitch thread cutter (var. modes)

Thread trimming in the chainstitch modes is performed at machine standstill in position 2.

The signal sequence of M1...M4 and sewing foot lifting at the seam end can be set as desired using parameters **280...288** (Parallel or sequential).

When the thread trimmer is off, the drive stops in position 2 at the seam end.

7.17.4 Chainstitch Machine Trimming Signal Times

Signal delay times and ON periods can be set with the help of the following parameters.

See chapter 8 »Setting the Basic Functions, Selection of Functional Sequences« in this manual for further information on chain stitch seam end variants and chapter »Timing Diagrams« in the List of Parameters.

Function		Parameters
Delay time output M1	(kd1)	280
ON period output M1	(kt1)	281
Delay time output M2	(kd2)	282
ON period output M2	(kt2)	283
Delay time output M3	(kd3)	284
ON period output M3	(kt3)	285
Delay time output M4	(kd4)	286
ON period output M4	(kt4)	287
Delay time until sewing foot On	(kdF)	288

7.18 Functions for bag sewing machines

Function with or without control panel	Parameters
Chainstitch machine functions e. g. bag sewing machine functions (Bag)	198

There are various setting possibilities in mode 5 using parameter **198**:

- 198 =0** Thread trimming or hot thread chain cutting and sewing foot lifting are enabled by means of the pedal.
- 198 =1** Thread trimming or hot thread chain cutting is enabled by means of the knee switch, and the sewing foot is lifted using the pedal.
- 198 =2** Thread trimming or hot thread chain cutting is enabled by means of the pedal, and the sewing foot is lifted by means of the knee switch.

For bag sewing machine operation the parameters indicated below must be adapted manually. For the knee switch select an input in1...i7, and set the corresponding parameter to "42".

Function with or without control panel	Parameters
Delay time output M2 (kd2)	282
ON period output M2 (impulse) (kt2)	283
Delay time output M3 for hot thread chain cutting (kd3)	284
M3 ON period output for hot thread chain cutting (kt3)	285
Delay time until sewing foot On (kdF)	288
Input for knee switch function (in1...in7)	240...246

7.19 Overlock Machine Functions (Mode 7)

7.19.1 Chain Suction Signal

The chain suction signal can be pre-selected for start and end counting, respectively, using the E key on the control and key 1 on the V810/V820 control panel. If chain suction and tape cutter are switched off at the start of the seam, the respective counts will be suppressed. But they will be performed at the seam end.

Function without control panel	Control
Chain suction at the start of the seam On	Segment 1 on
Chain suction at the end of the seam On	Segment 2 on

Function with control panel	V810/V820
Chain suction at the start of the seam On	left-hand arrow above key On
Chain suction at the end of the seam On	right-hand arrow above key On

Function with or without control panel		Parameters
Stop for tape cutting at the seam end On/Off	(SAb)	017
Sequence of the overlock mode (mode 7) with or without stop	(UoS)	018
Signal chain suction on seam end up to counted c2 or to pedal 0	(SPO)	022
Start counting (Parameter 157) for thread tension release at the start of the seam	(tFS)	025
Speed during the stitch count at the seam start	(kSA)	143
Speed during the stitch count at the seam end	(kSE)	144
Stitches until thread tension release Off after light barrier covered at the start of the seam	(SFS)	157
	(kSL)	193
Enable chain suction signal and thread tension release at the seam end	(FSn)	199
Thread tension release at the seam end until pedal in pos. 0 or until the next seam start is switched on	(bdO)	235
Braking curve in the overlock mode On/Off	(tkS)	237
Switch-off delay for chain suction at the seam end, if parameter 022 =2	(Abc)	267
Start count cancellation and seam end initiation by light barrier uncovered On/Off		

There are various setting possibilities with the following parameters in the overlock mode (mode 7).

- 018 =0** Sequence with stop.
- 018 =1** Sequence without automatic stop at the seam end. When the command "run" is given, the drive runs at the pre-selected speed. The program switches to the next start of a seam without issuing signals M1/M2, when the pedal is in pos. 0 (neutral) or the light barrier is covered.
- 018 =2** Sequence as with setting 1. But with pedal in pos. 0 signals M1/M2 will be issued, and the program switches to the next start of a seam.
- 018 =3** Sequence as with setting 1. But with pedal -2 signals M1/M2 will be issued, and the program switches to the next start of a seam. Intermediate stop and sewing foot lifting with pedal in pedal -1 is possible.
- 018 =4** If the light barrier is covered during the end count for chain suction, the program switches immediately to the next start of a seam. If the end count has been completed and the light barrier remains uncovered, the drive stops immediately.
- 018 =5** Tape cutting at the start of the seam with stop.
- 022 =0** The chain suction signal at the seam end is disabled after count c2.
- 022 =1** The chain suction signal at the seam end remains on until pedal in pos. 0 (neutral).
- 022 =2** Chain suction until the drive is at standstill and the switch-off delay (Parameter **237**) has elapsed. The switch-off delay will be disabled whenever a new seam is started.
- 025 =0** Start counting for thread tension release at the start of the seam.
- 025 =1** Start counting for thread tension release when the light barrier is covered.
- 193 =0** Thread tension release and chain suction after the light barrier compensating stitches.
- 193 =1** Chain suction from light barrier uncovered onwards and thread tension release after the light barrier compensating stitches.
- 199 =0** Thread tension release On at the seam end until pedal in pos. 0 (neutral).
- 199 =1** Thread tension release On at the seam end or at the start of the seam.
- 199 =2** Thread tension release On at the seam end or at the start of the seam and after "power On".
- 267 =0** Start count cancellation by light barrier uncovered impossible.
- 267 =1** Start count cancellation by light barrier uncovered.
Chain suction or tape cutting at the start of the seam are cancelled whenever the light barrier senses "uncovered", and the seam end will be initiated.

It is possible to select the speed function for stitch counting at the start of the seam and at the seam end using the following parameters.

- 143 =0** Speed controllable by the pedal up to the set maximum speed (Parameter **111**).
- 143 =1** Fixed speed (Parameter **112**) without an affect by the pedal. Stop with pedal in pos. 0.
- 143 =2** Limited speed (Parameter **112**) controllable by the pedal up to the set limit.
- 143 =3** At fixed speed (Parameter **112**), can be cancelled or interrupted depending on the setting of parameter **019**.
- 144 =0** Speed controllable by the pedal up to the set maximum speed (Parameter **111**).
- 144 =1** Fixed speed (Parameter **113**) without an affect by the pedal. Stop with pedal in pos. 0.
- 144 =2** Limited speed (Parameter **113**) controllable by the pedal up to the set limit.
- 144 =3** At fixed speed (Parameter **113**), can be cancelled or interrupted depending on the setting of parameter **019**.

7.19.2 Start and End Counts

Function with or without control panel		Parameters
End count (c2) at limited speed n4 until stop	(c2)	000
Start count (c1) at limited speed n3 for chain suction	(c1)	001
Count (c3) tape cutter at the start of the seam	(c3)	002
End count (c4) for tape cutter at the seam end	(c4)	003
Seam end in mode 7 through end count (c2) or (c4)	(mhE)	191
Stitch counting speed at the start of the seam	(n3)	112
Stitch counting speed at the seam end	(n4)	113

The following settings are possible for determining the seam end using **parameter 191**:

- 191 =0** Seam end after count c4 – tape cutter
- 191 =1** Seam end after count c2 – chain suction

7.20 Tape Cutter/Fast Scissors (Modes 6/7)

7.20.1 Tape Cutter/Fast Scissors in Mode 6

The signal **tape cutter/fast scissors** is issued only at the seam end. Furthermore, the manual tape cutter/fast scissors function can be set. See also chapter "**Manual Tape Cutter/Fast Scissors**".

Function with or without control panel	Parameters
Tape cutter at the seam end On/Off	014

Output and Times for Tape Cutter

Function with or without control panel		Parameters
Delay time for output M3 (ST2/27) tape cutter AH	(kd3)	284
ON period for output M3 (ST2/27) tape cutter AH	(kt3)	285

- Parameter **232** must be set at "**0**" (tape cutter function).
- The delay time for the tape cutter is usually set at "**0**".

Output and Times for Fast Scissors

Function with or without control panel		Parameters
Delay time for output M3 (ST2/27) fast scissors AH1	(kd3)	284
ON period for output M3 (ST2/27) fast scissors AH1	(kt3)	285
Delay time for output M4 (ST2/36) fast scissors AH2	(kd4)	286
ON period for output M4 (ST2/36) fast scissors AH2	(kt4)	287

- Parameter **232** must be set at "**1**" (fast scissors function).
- The delay times for "fast scissors" are usually set at "**0**".

7.20.2 Tape Cutter/Fast Scissors in Mode 7

The signal tape cutter/fast scissors can be set separately for start and end counting. See also chapter "Manual Tape Cutter/Fast Scissors".

Function without control panel		Control
Tape cutter/Fast scissors at the start of the seam On	Segment 3 on	key + (S3)
Tape cutter/Fast scissors at the end of the seam On	Segment 4 on	
Tape cutter/Fast scissors at the start and end of the seam On	Segment s 3 and 4 on	
Tape cutter/Fast scissors at the start and end of the seam Off	LEDs 3 and 4 off	

- When using the V810 control panel, parameter **291** will automatically be set to slide-in strip "**7**" if **290 =7**.
- When using the V820 control panel, parameter **292** will automatically be set to slide-in strip "**5**" if **290 =7**.

Function with control panel	V810	V820

Tape cutter/Fast scissors at the start of the seam On	left-hand arrow above key	Key 2	Key 4
Tape cutter/Fast scissors at the end of the seam On	key On		
Tape cutter/Fast scissors at the start and end of the seam On	right-hand arrow above key		
Tape cutter/Fast scissors at the start and end of the seam Off	key On		
	both arrows above key		
	On		
	both arrows above key		
	Off		

The tape cutter signal can be influenced by parameter **020** in such a way that the signal remains on at the seam end and is off when you begin sewing again after some run-out stitches, which can be set using parameter 021. This action serves as clamp.

Function with or without control panel		Parameters
Clamp at the seam end (output ST2/27) On/Off (mode 7)	(kLm)	020
Run-out stitches from the clamp at the seam start (mode 7) or	(ckL)	021
Stitch count after the light barrier uncovered until the tape cutter is on (mode 15)		

Output and Times for Tape Cutter

Function		Parameters
Delay time for output M3 (ST2/27) tape cutter AH	(kd3)	284
ON period for output M3 (ST2/27) tape cutter AH	(kt3)	285

- Parameter **232** must be set at "0" (tape cutter function).
- The delay time for the tape cutter is usually set at "0".

Output and Times for Fast Scissors

Function		Parameters
Delay time for output M3 (ST2/27) fast scissors AH1	(kd3)	284
ON period for output M3 (ST2/27) fast scissors AH1	(kt3)	285
Delay time for output M4 (ST2/36) fast scissors AH2	(kd4)	286
ON period for output M4 (ST2/36) fast scissors AH2	(kt4)	287

- Parameter **232** must be set at "1" (fast scissors function).
- The delay times for "fast scissors" are usually set at "0".

7.21 Manual Tape Cutter/Fast Scissors

Upon pressing an external key depending on the pre-selection of parameters **240...246**, the **tape cutter** or **fast scissors** can be enabled anywhere in the seam or at standstill.

See also chapter "Connection Diagram" in the List of Parameters!

7.22 FlipFlop functions (AFF)

Function	Parameters
FlipFlop 1	(AFF1) 830

Output assignment

Linking

F-830 =0	AFF1 =Off (preset)	F-038 =0	Linking off (preset)
F-830 =1	AFF1 =M1	F-038 =1	Linking with FSPL
F-830 =2	AFF1 =M2	F-038 =2	Linking with "high lift for walking foot"
F-830 =3	AFF1 =M3	F-038 =3	Linking with FSPL & with "high lift for walking foot"
F-830 =4	AFF1 =M4		
F-830 =5	AFF1 =M5	F-039 =0	Linking off (preset)
F-830 =6	AFF1 = M6	F-039 =1	Linking with foot lifting (in the seam)
F-830 =7	AFF1 = M7	F-039 =2	Linking with foot lifting (at the seam end)
F-830 =8	AFF1 = M8	F-039 =3	Linking with foot lifting (in and at the end of the seam)
F-830 =9	AFF1 = M9		
F-830 =10	AFF1 = M10		
F-830 =11	AFF1 = M11		

Inputs assignment: F-24x =101

Function	Parameters
FlipFlop 2	(AFF2) 831

Output assignment

F-831 =0	AFF2 =Off (preset)
F-831 =1	AFF2 =M1
F-831 =2	AFF2 =M2
F-831 =3	AFF2 =M3
F-831 =4	AFF2 =M4
F-831 =5	AFF2 =M5
F-831 =6	AFF2 = M6
F-831 =7	AFF2 = M7
F-831 =8	AFF2 = M8
F-831 =9	AFF2 = M9
F-831 =10	AFF2 = M10
F-831 =11	AFF2 = M11

Inputs assignment: F-24x =102

Function	Parameters
FlipFlop 3	(AFF3) 832

Output assignment

Linking

F-832 =0	AFF3 = Off (preset)	F-040 = 0	Linking off (preset)
F-832 =1	AFF3 = M1	F-040 = 1	AFF3 off when foot lifting is active
F-832 =2	AFF3 = M2	F-040 = 2	AFF3 off when interlock is active
F-832 =3	AFF3 = M3	F-040 = 3	AFF3 is off when locking or
F-832 =4	AFF3 = M4		foot lifting is active
F-832 =5	AFF3 = M5		
F-832 =6	AFF3 = M6		
F-832 =7	AFF3 = M7		
F-832 =8	AFF3 = M8		
F-832 =9	AFF3 = M9		
F-832 =10	AFF3 = M10		
F-832 =11	AFF3 = M11		

Inputs assignment: F-24x =103

7.23 Seam with Stitch Counting

Function without control panel		Parameters
Stitch counting On/Off	(n7)	015

Function with control panel		V820
Stitch counting On/Off		Key 2

7.23.1 Number of Stitches for a Seam with Stitch Counting

Function with or without control panel		Parameters
Number of stitches for the seam with stitch counting	(Stc)	007

The number of stitches for stitch counting can be set directly on the control with parameter **007** or on a connected V810/V820 control panel.

For fast operator information (HIT) when using the V820 control panel, the value of the function switched on using key **2** can be displayed for approx. 3 seconds. During this time, the value can be varied directly by pressing key **+/-**.

7.23.2 Stitch Counting Speed

Function		Parameters
Positioning speed	(n1)	110
Stitch Counting Speed	(n12)	118
Speed mode for a seam with stitch counting	(SGn)	141

A certain speed behavior for the stitch counting can be selected using **parameter141**.

- 141 =0** Execution at pedal controlled speed
- 141 =1** Execution at fixed speed n12, when pressing the pedal forward (position >1)
- 141 =2** Execution at limited speed n12, when pressing the pedal forward (position >1)
- 141 =3** Automatic execution at fixed speed after having pressed the pedal once. The procedure can be interrupted by "heelback (-2)"
- 141 =4** Automatic execution at fixed speed n1 after having pressed the pedal once. The procedure can be interrupted by "heelback (-2)"

The sewing speed is reduced in each stitch depending on the actual speed (max. 11 stitches before the end of stitch counting), in order to be able to stop exactly at the end of counting. When the light barrier is on, free sewing will be performed after stitch counting.

7.23.3 Seam with Stitch Counting When Light Barrier Is On

Function with or without control panel		Parameters
Light barrier On/Off	LS	009
Stitch counting On/Off	(StS)	015

Function with control panel		V820
Light barrier On/Off		Key 3
Stitch counting On/Off		Key 2

When "stitch counting and light barrier function" is set, the number of stitches will be executed first, then the light barrier will be activated.

7.24 Free Seam and Seam with Light Barrier

Function		Parameters
Positioning speed	(n1)	110
Upper limit of maximum speed	(n2)	111
Limited speed according to setting of parameter 142	(n12)	118
Lower limit of maximum speed	(n2_)	121
Speed mode free seam	(SFn)	142

Speed control for the free seam and the seam with stitch counting can be selected using the speed mode.

- 142 =0** Execution at pedal controlled speed
142 =1 Execution at fixed speed n12, when pressing the pedal forward (position >1)
142 =2 Execution at limited speed n12, when pressing the pedal forward (position >1)
142 =3 Only for the seam with light barrier:
 - Automatic execution at fixed speed after having pressed the pedal once.
 - The seam end is initiated by light barrier.
 - The procedure can be interrupted by heelback (-2).
 - If the light barrier is not on, speed as with parameter setting **142 = 0**.

When using a control panel, the maximum speed is displayed after power on and thread trimming and can be varied directly using the +/- keys on the control panel. The setting range lies between the values of parameters **111** and **121**.

7.25 Light barrier

Function with or without control panel	Parameters
Light barrier On/Off	009

Function with control panel	V820
Light barrier covered/uncovered On	Right-hand arrow above key On
Light barrier uncovered/covered On	Left-hand arrow above key On
Light barrier Off	Both arrows Off

The light barrier function at the input of socket B18/8 is active only if parameter value **239 = 0**.

7.25.1 Speed after Light Barrier Sensing

Function with or without control panel	Parameters
Speed after Light Barrier Sensing	(n5) 114

At the end of the light barrier stitch count at speed n5, the end count for the tape cutter (c4) is continued under pedal control. If the stitch count for the tape cutter is set to 0 and the light barrier balancing stitch count set until the tap cutter is introduced, then the count is done independently of the pedal at a speed of n5.

7.25.2 General Light Barrier Functions

Function		Parameters
Light barrier compensating stitches	LS	004
Number of light barrier seams	(LSn)	006
Light barrier sensing uncovered/covered	(LSd)	131
Start of sewing blocked/unblocked with light barrier uncovered	LSS	132
Light barrier seam end with thread trimming On/Off	(LSE)	133
Speed of the light barrier compensating stitches	PLS	192

- After sensing the seam end, the compensating stitches are counted at light barrier speed.
- Suspension of the procedure with pedal in pos. 0 (neutral). Interruption of the procedure with pedal in pos. -2.
- The thread trimming operation can be disabled using parameter **133**, regardless of the setting of key **5** on the V820 control panel. Stop in the basic position.
- Programming of max. 15 light barrier seams depending on the setting of parameter **006** with stop in the basic position. Thread trimming after the last light barrier seam.
- Light barrier sensing uncovered or covered at the seam end can be selected using parameter **131**.
- Start blockage with light barrier uncovered programmable using parameter **132**.

- Speed selection pedal controlled / n5 during the light barrier compensating stitches using parameter **192**.

The light barrier compensating stitches can be programmed and varied using the above parameters directly on the control or on a connected V810/V820 control panel.

For fast operator information (HIT) when using the V820 control panel, the value of the function switched on using key **3** can be displayed for approx. 3 seconds. During this time, the value can be varied directly by pressing key **+** or **-**.

When using a V820 control panel, direct access by means of the function key (key 9) is possible.

Function with control panel		Parameters
Start of sewing blocked with light barrier uncovered On/Off	(-F-)	008 =3

7.25.3 Reflection Light Barrier LSM002

Sensitivity setting:

Set minimum sensitivity depending on the distance between light barrier and reflection area (turn potentiometer as far as possible to the left).

- Potentiometer directly on the light barrier module

Mechanical orientation:

Orientation is facilitated by a visible light spot on the reflection area.

7.25.4 Automatic Start Controlled by Light Barrier

This function is not possible when parameter F-290 =8 or 9 (modes 8 and 9)!

Function		Parameters
Delay of automatic start	(ASd)	128
Automatic start On/Off	(ALS)	129
Light barrier sensing uncovered	(LSd)	131
Start of sewing blocked with light barrier uncovered	LSS	132

This function enables an automatic start of the sewing operation as soon as the light barrier senses the insertion of fabric.

Prerequisites for the operation:

- Parameter **009 = 1** Light barrier On
- Parameter **129 = 1** Automatic start On
- Parameter **131 = 1** Light barrier sensing uncovered
- Parameter **132 = 1** No start of sewing with light barrier uncovered
- The pedal must be kept pressed forward at the seam end.

For safety reasons this function is enabled only after a normal start of sewing. The light barrier must be covered as long as the pedal is in position 0. Then press the pedal forward. This function is disabled when the pedal is no longer pressed forward after the seam end.

7.25.5 Light barrier filter for knitted fabrics

Function		Parameters
Number of stitches of the light barrier filter	(LSF)	005
Light barrier filter On/Off	(LSF)	130
Light barrier sensing uncovered or covered	(LSd)	131

The filter prevents premature enabling of the light barrier function when sewing knitted fabrics.

- Enabling/Disabling of the filter using parameter **130**
- The filter is not active if parameter **005 = 0**
- Adaptation to the mesh is possible by varying the number of filter stitches.
- Knitted fabric sensing with light barrier
 - Uncovered → covered, if parameter **131 = 0**.
 - Covered → uncovered, if parameter **131 = 1**.

7.25.6 Functional Variations of the Light Barrier Input

Function	Parameters
Selection of the input function on socket B18/8	239

If the light barrier function is not used, a switching function can be assigned to the input on socket B18/8 as well as to inputs in1...i7.

The following input functions are possible with parameter **239**

239 =0 Light barrier function: The input is prepared for a light barrier function.

239 =>0 All other input functions are identical, as described in the next section "Inputs for switches and keys".

7.26 Switching Functions of Inputs in1...i13

Function		Parameters
Selection of the input function	(in1...in7) (in11-LSM) (in12...in13)	240...246 239 550...551

The functions of the keys/switches connected to socket connectors ST2, B18 and B22 can be selected for inputs in1...in13 using parameters **240...246, 239 (LSM), 550, 551**.

240...246, 239 (LSM), 550, 551 =

0 Input function blocked.

- 1 **Needle up/down:** Upon pressing the key, the drive runs from position 1 to position 2 or from position 2 to position 1. If the drive is outside of the stop position, it moves to the preselected home position.
- 2 **Needle up:** Upon pressing the key, the drive runs from position 1 to position 2.
- 3 **Single stitch (basting stitch):** Upon pressing the key, the drive performs one rotation from position 1 to position 1. If the drive is in position 2, it runs to position 1 upon pressing the key and from position 1 to position 1 each time the key is pressed again.
- 4 **Full stitch:** Upon pressing the key, the drive performs a full rotation depending on the set stop position.
- 5 **Needle to position 2:** If the drive is outside of position 2, then after pushing the key it moves to position 2. After the power is switched on, the drive runs until it has synchronized.
- 6 **Machine run blockage effective with open contact:** Upon opening the switch, the drive stops in the preselected basic position.
- 7 **Machine run blockage effective with closed contact:** Upon closing the switch, the drive stops in the preselected basic position.
- 8 **Machine run blockage effective with open contact (unpositioned):** Upon opening the switch, the drive stops immediately unpositioned.
- 9 **Machine run blockage effective with closed contact (unpositioned):** Upon closing the switch, the drive stops immediately unpositioned.
- 10 **Run at automatic speed (n12):** Upon pressing the key, the drive runs at automatic speed. The pedal is not used. (This input function is inverted in mode 9.)
- 11 **Run at limited speed (n12):** Upon pressing the key, the drive runs at limited speed. The pedal must be pressed forward.
- 12 **Sewing foot lifting with pedal in position 0 (neutral).**
- 15 **Tape cutter or fast scissors (mode 6/7):** Upon pressing the key, the tape cutter will be enabled for a preset time.
- 18 **Unlocking the chain:** Upon pressing the key, the motor performs a reverse rotation at the seam end. Moreover, backtacking and thread trimmer will be suppressed.
- 24 **Needle to position 2:** Upon pressing the key, the drive runs from position 1 to position 2, and the sewing foot is lifted. The start is blocked after that. Upon pressing the key again, the sewing foot is lowered, and the start is possible again.
- 27 **Unlocking the chain:** Upon pressing the key, the function "unlock the chain" will be performed without using the pedal.
- 28 **External light barrier:** In this mode it is possible to initiate the seam end using a key, not the light barrier. But the light barrier function must be On.
- 33 **Speed n9:** Below this speed, operation can be pedal controlled.
- 34 **Automatic speed n9:** The speed can be suspended by pressing the pedal to position 0.
- 37 **Speed n12 with break contact:** Below this speed, operation can be pedal controlled.
- 38 **Automatic speed n12 with break contact:** Not influenced by the pedal.
- 41 **Tape cutting only at machine standstill.**
- 42 **Enable hot thread chain cutting or sewing foot lifting:** Function only effective in mode 37
- 43 **No function**
- 44 **Functions the same as actuating the pedal -2:** When the key is pushed the seam end is introduced. If the functions "end backtack" and "trimming operation" are activated, they will be completed. The drive stops in position 2.
- 45 **- 90 No function**
- 91 **Threading mode 66**
- 92 **- 100 No function**
- 101 **Signal AFF1 switchable as flip-flop:** Upon pressing the key, signal AFF1 is activated and deactivated when pressing the key again.
- 102 **Signal AFF2 switchable as flip-flop:** Upon pressing the key, signal AFF2 is activated and deactivated when pressing the key again.

- 103 **Signal AFF3 switchable as flip-flop:** Upon pressing the key, signal AFF3 is activated and deactivated when pressing the key again, manual lock automatic
- 104 **Manual lock automatic**
- 105 -109 **No function**
- 109 **Part lift mode 66**
- 110 **No function**
- 111 **Machine run blockage effective in Pos. 2 at the seam end with closed contact**
- 112 **Foot lifting FlipFlop**
- 113– 117 **No function**
- 118 **FlipFlop for running at maximum speed**

7.27 Software Debouncing of All Inputs

Function with or without control panel	Parameters
Software debouncing of all inputs (EnP)	238

- 238 =0 No debouncing
- 238 =1 Debouncing

7.28 F1/F2 Function Key Assignment on the V810/V820 Control Panels

Function with control panel	Parameters
Selection of input function on the (A) "F1" key on the V810/V820 control panels (tF1)	293
Selection of input function on the (B) "F2" key on the V810/V820 control panels (tF2)	294

The function of the keys F1 (A) and F2 (B) can be selected on the control panels using parameters **293 and 294**.

293/294 =

- 0 **Input function blocked**
- 1 **Needle up/down:** Upon pressing the key, the drive runs from position 1 to position 2 or from position 2 to position 1. If the drive is outside of the stop position, it moves to the preselected home position.
- 2 **Needle up** Upon pressing the key, the drive runs from position 1 to position 2.
- 3 **Single stitch (basting stitch):** Upon pressing the key, the drive performs one rotation from position 1 to position 1. If the drive is in position 2, it runs to position 1 upon pressing the key and from position 1 to position 1 each time the key is pressed again.
- 4 **Full stitch:** Upon pressing the key, the drive performs a full rotation depending on the stop position.
- 5 **Needle to position 2:** If the drive is outside of position 2, then after pushing the key it moves to position 2. After the power is switched on, the drive runs until it has synchronized.
- 6...12 **No function**
- 13 **High lift for walking foot operational mode not stored:** The signal "high lift for walking foot" is issued as long as the key is held down, and the drive runs with speed limitation (n10).
- 14 **High lift for walking foot operational mode stored /flip-flop 1:** The signal "high lift for walking foot" is issued upon briefly pressing the key, and the drive runs with speed limitation (n10). The operation is disabled upon pressing the key again.
- 15 **Tape cutter or fast scissors (mode 6/7):** Upon pressing the key, the tape cutter will be enabled for a preset time.
- 16 **Intermediate Backtack:** Upon pressing the key, the backtack will be enabled anywhere in the seam and at standstill of the drive.
- 17 **Backtack suppression / recall:** Upon pressing the key, the backtack will be suppressed or recalled once.
- 18 **No function**
- 19 **Bobbin thread monitor**
- 20...100 **No function**

7.29 Special pedal function Single stitch / Full stitch

Function		Parameters
Special pedal function Single stitch / Full stitch	(EZP)	041
Pedal travel forwards for detection of the special pedal function	(GrP)	042
Time for detection of the special pedal function	(dPd)	051
Speed for single stitch / full stitch	(n9)	122

With the single stitch / full stitch function, it is possible to enable the execution of a stitch though pedal forwards actuation. For this it is necessary to move the pedal forward only far enough so that the percentage portion (e.g., 40%) of the maximum possible pedal travel (100%) set by the parameter **042**, is not exceeded.

The execution is done as single stitch (Parameter **041 = 1**) or full stitch (Parameter **041 = 2**)

If the travel set with parameter **042** is exceeded within the time set with parameter **051**, the drive runs with the speed specified by the respective pedal setting, even when under the threshold.

First after pedal 0-position can the special pedal function be actuated again.

The single/full stitch is executed in the speed set with parameter **122**. To ensure that only a single stitch is executed, the setting 300 rpm must not be exceeded.

041 =0 Special pedal function Off

041 =1 Single stitch:

The performs one rotation from position 1 to position 1. If it is standing in position 2, it runs to position 1 the first time and then each time from position 1 to position 1.

041 =2 Full stitch:

The drive executes a complete rotation corresponding to its starting position.

7.30 Signal "Machine Running"

Function		Parameters
Mode "machine running"	(LSG)	155
Switch-off delay for signal "machine running"	(t05)	156

Set activation of signal "machine running" using parameters 155/156 .

155 =0 Signal "machine running" Off.

155 =1 Signal "machine running" will be issued whenever the drive is running.

155 =2 The signal "machine running" will be issued whenever the speed is higher than 3000 RPM

155 =3 Signal "machine running" will be issued whenever the pedal is not in position 0 or neutral.

155 =4 Signal "machine running" will be issued only after motor synchronization (one rotation at positioning speed after power On).

156 Delay of switch-off time.

7.31 Signal Output Position 1

- Transistor output with open collector (max. +40 V, I_{max} 10 mA)
- Signal whenever the needle is in the slot between position 1 and 1A
- Independent of sewing, thus also when turning the handwheel manually
- Suitable e. g. for the connection of a counter
- An inverted signal is issued at socket ST2/22

7.32 Signal Output Position 2

- Logic level output (+5 V, I_{max} 5 mA)
- Signal whenever the needle is in the slot between position 2 and 2A
- Independent of sewing, thus also when turning the handwheel manually
- Suitable e. g. for the connection of a counter
- An inverted signal is issued at socket B18/9

7.33 Signal Output 512 Impulses per Rotation

- Logic level output (+5 V, I_{max} 5 mA)
- Signal whenever a generator slot of the position transmitter is sensed
- 512 impulses per rotation of the handwheel

- Independent of sewing, thus also when turning the handwheel manually
- Suitable e. g. for the connection of a counter
- A signal is issued at socket B18/1+6

7.34 Actuator

7.34.1 Analog actuator

Function with or without control panel	Parameters
Selectable pedal functions	(-Pd) 019
Characteristic of the "analog pedal" EB401	(APd) 026

The effect of pedal actuation on the drive functions can be set using parameter **019**:

- 019 =0** Pedal in pos. -1 (slightly back) blocked in the seam. But with pedal in pos. -2 (all the way back) sewing foot lifting is possible in the seam (function active whenever the light barrier is On).
- 019 =1** With pedal in pos. -1 (slightly back) sewing foot lifting is blocked in the seam.
- 019 =2** With pedal in pos. -2 (all the way back) thread trimming is blocked (function active whenever the light barrier is On).
- 019 =3** The functions "pedal in pos. -1 (slightly back) and "pedal in pos -2 (all the way back) are active.
- 019 =4** The functions "pedal in pos. -1" (slightly back) and "pedal in pos. -2" (all the way back) are blocked in the seam (function active whenever the light barrier is On).
- 019 =5** Start seam end by placing the portal at -1 (slightly back)

The characteristics of the "analog pedal" is adjustable with parameter **026**:

- 026 =0** Analog function off
- 026 =1** 12-level selected, like prior pedal function of the digital actuator.
- 026 =2** Continuously variable (i.e. for external potentiometer, without trimming function)
- 026 =3** 24-level
- 026 =4** 60-level
- 026 =5** 48-level
- 026 =6** 40-Step for SOP (standing operation)

8 Signal Test

Function with or without control panel	Parameters
Input and output test	(Sr4) 173

Function test of external inputs, multiple-function key bar and transistor power outputs with connected actuators (e.g. solenoids and solenoid valves).

8.1 Signal Test Using the Incorporated Control Panel or the V810/V820

8.1.1 Inputs to the control

- Select parameter **173** (OFF is displayed).
- **Control pad on controller:** By actuating the keys or switches connected to inputs in1 to in7, the number of the input actuated appears on the display, e.g. **i06**. More than one switch and/or key may not be actuated at the same time.
If more than one key or switch is activated at once, the number of the lowest-numbered input is displayed.
If, for example, **in3, in5, in6, in7** are actuated, **i03** is displayed.
- **V810 control panel:** The numbers of the inputs in1...in7, in11 (LSM), in12, and in13 appear individually on the LCD display. Here, too, several switches and/or keys may not be actuated at the same time.
The signals "Light barrier, sensor (IPG... or HSM...), generator pulses 1 and 2, position 1 and 2" can be checked directly for functionality. The display is carried out using the arrows assigned to keys 2 to 4

Note: Checking of positions is described in chapter "Displaying the signal and stop positions".

Display example for input 03 on the V810 control panel:

→ **in i03**

- **V820 control panel:** The numbers of the inputs in1...in7, in11 (LSM), in12, and in13 appear individually on the LCD display. In addition, the active inputs are displayed by arrows over keys 1 through 6, even if multiple inputs are actuated at once.
 - If more than one key or switch is activated at once, the number of the lowest-numbered input is displayed. If, for example, **in3, in5, in6, in7** are actuated, **03** is displayed.
- The signals "Light barrier, positions, etc." are displayed by arrows above keys 8, 9, 0.

Display example for input 03 on the V820 control panel:

→ **2-06 in 03**

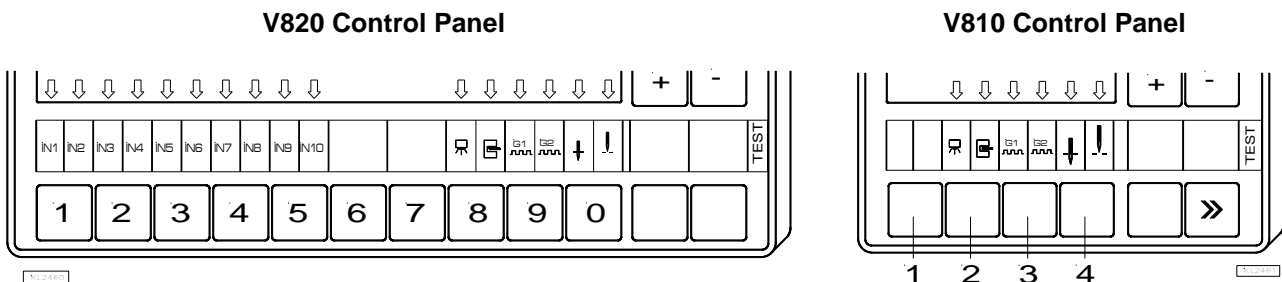

NOTE

If an input is active with open contact, the corresponding arrow lights up when the contact is open. If an input is active with closed contact, the corresponding arrow lights up when the contact is closed!

8.1.2 Outputs of control

- Select parameter **173**.
- Select the desired output using the **+/-** keys.
- On the V810 control panel or on the built-in keypad in the control, the **>>** key is used to turn on the associated output, if it is connected and working.
- On the V820 control panel, instead of the **>>** key the key lower right, at the outer edge must be pressed.

Display example for backtacking output on the V810 control panel:

→ **2-34 oUt vr**

Display example for backtacking output on the V820 control panel:

→ **2-34 oUt vr**

9 Table of Machine Functions and Adapter Cords



ATTENTION

Before switching functional sequences, detach cables from the inputs and outputs! It must be absolutely certain that for the functional sequence to be changed the machine provided has been installed! Then proceed with the setting using parameter 290!

Setting the functional sequence using parameter 290

				Functions / Outputs						
		Power transistors →	FL	VR	M1	M2	M3	M4	M5	
Mode	Function / Machine	Adapter	ST2/35	ST2/34	ST2/37	ST2/28	ST2/27	ST2/36	ST2/32	
0	Lockstitch: e. g.		FL	VR	FA1	FA2	FW	FA1+2	ML	
	Brother (737-113, 737-913)	1113420	FL	VR	FA1	FA2	FW			
	Aisin (AD3XX, AD158, 3310; EK1)	1112815	FL	VR	FA1	FA2	FW			
	Pfaff (563, 953, 1050, 1180)	1113746	FL	VR	FA1	FA2	FW		ML	
	Dürkopp Adler (210, 270)	1112845	FL	VR	FA1	FA2	FW			
2	Lockstitch: e. g.		FL	VR		FA	FSPL	FL1	ML	
	Singer (212 UTT)	1112824	FL	VR		FA	FSPL	FL1		
3	Lockstitch: e. g. Dürkopp Adler (467)		FL	VR	FA	ML	FW	FSPL		
5	Chainstitch: parallel sequence		FL	STV	AH1	AH2	AH3	AH4	ML	
	Yamato (VC/VG series)	1113345	FL	STV	FA		FW		ML	
	Kansai (RX 9803)	1113130	FL		FA		FW		ML	
	Pegasus (W500/UT, W600/UT/MS with or without stitch condensing)	1112821	FL	STV	FA	FA	FW			
	Union Special (34700)	1112844	FL	STV	FA	FA	FW		ML/NK	
	Global (CB2803-56)	1112866	FL				FA			
	Rimoldi (F27)	1113096	FL		FW	FAO	FAU		ML	
6	Chainstitch: tape cutter/fast scissors		FL	STV	FA	M2	AH1	AH2	ML	
7	Overlook		FL	KS	FA	M2	AH	FSPL	ML	
8	Backlatch		FL		PD≤-1	PD≥1	PD≥1*		ML	
	Pegasus	1113234			PD≤-1	PD≥1				
9	Backlatch		FL		PD≤-1	PD≥1	PD≥1*		ML	
	Yamato (ABT3)	1112826			PD≤-1	PD≥1				
	Yamato (ABT13, ABT17)	1113205			PD≤-1	PD≥1				
14	Lockstitch: e. g.		FL	VR	FA1+2	FA2	FW	FA1	ML	
	Juki (5550-6)	1112816	FL	VR	FA1+2		FW			
	Juki (5550-7, 8500-7, 8700-7)	1112816	FL	VR	FA1+2		FW			
	With short trimmer Adapter for position sensors incorporated in the handwheel	1113157								
25	Lockstitch: JUKI (LU2210 / LU2260)		FL	VR	FA	FSPL	FW	HP	ML	
37	Heavy duty bag machine Union Special		FL			IMP	BR		M2	
38	Lockstitch: : e. g. HonYu class HY-4410		FL	VR	FA1	FA2	AFF2	AFF1	MST/HP	
53	Lockstitch: : e. g. Juki (LU2810-6)		FL	VR	FA1	FA2	AFF2	AFF1	MST/HP	
55	Chainstitch with UTQ: e. g. Yamato		FL	VR	AH1	M2	M3	M4	M2	
56	Strobel: Replacement for ST220		FL	VR	AH1	AH1	BS		M2	
57	Lockstitch: e. g. Typical Kl. TW1-591		FL	VR	FA	M2		FSP2		
58	Lockstitch: e. g. Juki PLC 2760		FL	VR	FA1	AFF3	FA3	FSP2	MST/HP	
59	Lockstitch: e. g. DA class 768		FL	VR	FA1	AFF3	FA3	FA2	MST/HP	
60	Lockstitch: e. g. Typical class 1245		FL	VR	FA1	M2	FA3	FA2	MST/HP	
61	Lockstitch: e. g. Kaiser class 570/590		FL	VR	FA	M2	2FSRL	FSP2		
62	Lockstitch: e. g. Typical/Mauser class 335		FL	VR	FA	M2	FW	FSP2	MST/HP	
63	Lockstitch: e. g. Juki DNU 1541-7		FL	VR	FA	FSP2	AFF2	AFF1	MST/HP	
65	Kettenstich: e. g. Sagitta		FL	STV	AH1	AH2	AH3	AH4	ML	

*) The signal issued at this output is inverted!

Explanation of letter symbols of the above table and chapter "Timing Diagrams"			
Outputs		Outputs	
AH	Tape cutter	FL1	Sewing foot lifting without pulsing
AH1/AH2	Fast scissors	FSPL	Thread tension release
FA	Thread trimmer	FW	Thread wiper
FA1	Thread trimmer pos. 1...1A (e.g. Pfaff, magnetic)	ML/NK	Machine running / Needle cooling
FA1+2	Thread trimmer pos. 1...2	PD \geq 1	Pedal forwards until the engine is running (min. to max. rotational speed)
FA2	Thread trimmer pos. 1A...2 (e.g. Pfaff, pneumatic)	PD \leq -1	Pedal slightly back (FL) or entirely back (FA)
FAO	Needle thread trimmer	PD=0	Pedal in pos. 0 (neutral)
FAU	Bobbin thread trimmer	PD-2	Full heelback (FA)
FL	Sewing foot lifting	VR	Backtacking

10 Operating Elements and Socket Connectors

10.1 Positions of the Front Side

A	Power switch
B	Network control lights
C	Control panel (onboard module) + Display (4-digit 7-segment display)
Key	
P	Call or exit programming mode
E	Start backtack single / double / off Enter key for modifications in the programming mode
+	End backtack single / double / off In the programming mode - increase of the value indicated
>>	Basic position 1 or 2 In programming mode as shift key
-	Automatic sewing foot lifting at stop in the seam On/Off Automatic sewing foot lifting after thread trimming On/Off In the programming mode - decrease of the value indicated
The upper vertical segments of the 4 digit 7 segment display indicate the switching states of foot lifting and basic position.	
1	Single start backtack
2	Double start backtack
3	Single end backtack Tape cutter at the start of the seam ON/OFF (mode 7)
4	Double end backtack Tape cutter at the seam end ON/OFF (mode 7)
5	Basic position "needle position 1"
6	Basic position "needle position 2"
7	Automatic sewing foot lifting at stop in the seam
8	Automatic sewing foot lifting after the thread trimming operation
Connector	
B20	USB Memory Stick

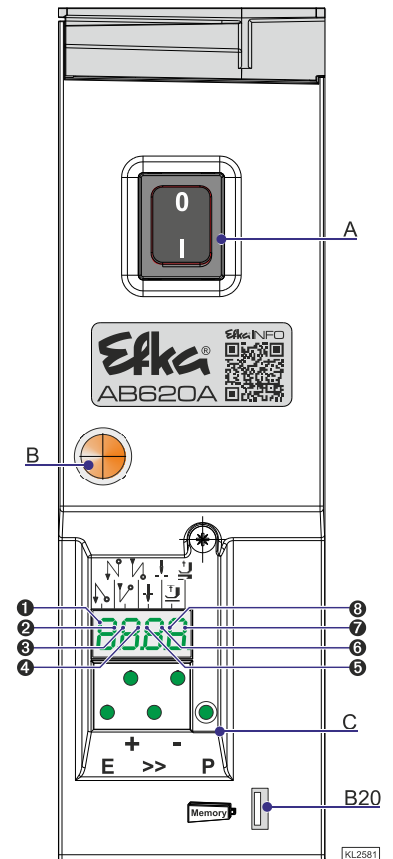

10.2 Positions of the rear side

Connector	
B2	Commutation transmitter
B18	Light barrier module LSM002 - Hall sensor module HSM001 - Pulse encoder IPG001 (Adapter cord 1113229 in case of multiple assignment)
B41	Motor power supply
B80	Actuator
ST2	Socket for inputs and outputs e. g. solenoids, solenoid valves, displays, keys and switches
B776	V810/V820 Control Panel
B22 (KN19)	Knee switch

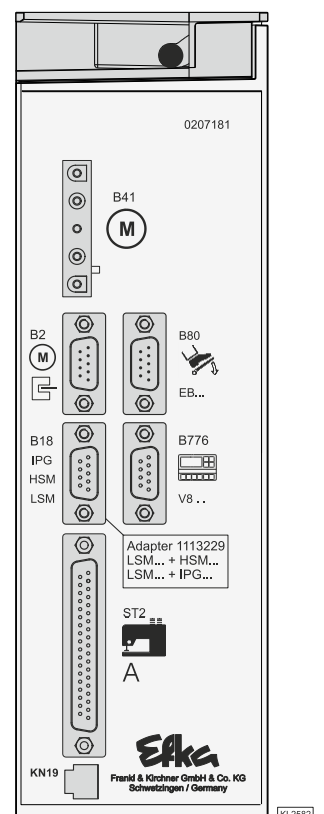

10.3 Connection Diagrams

Inputs switched to 0V

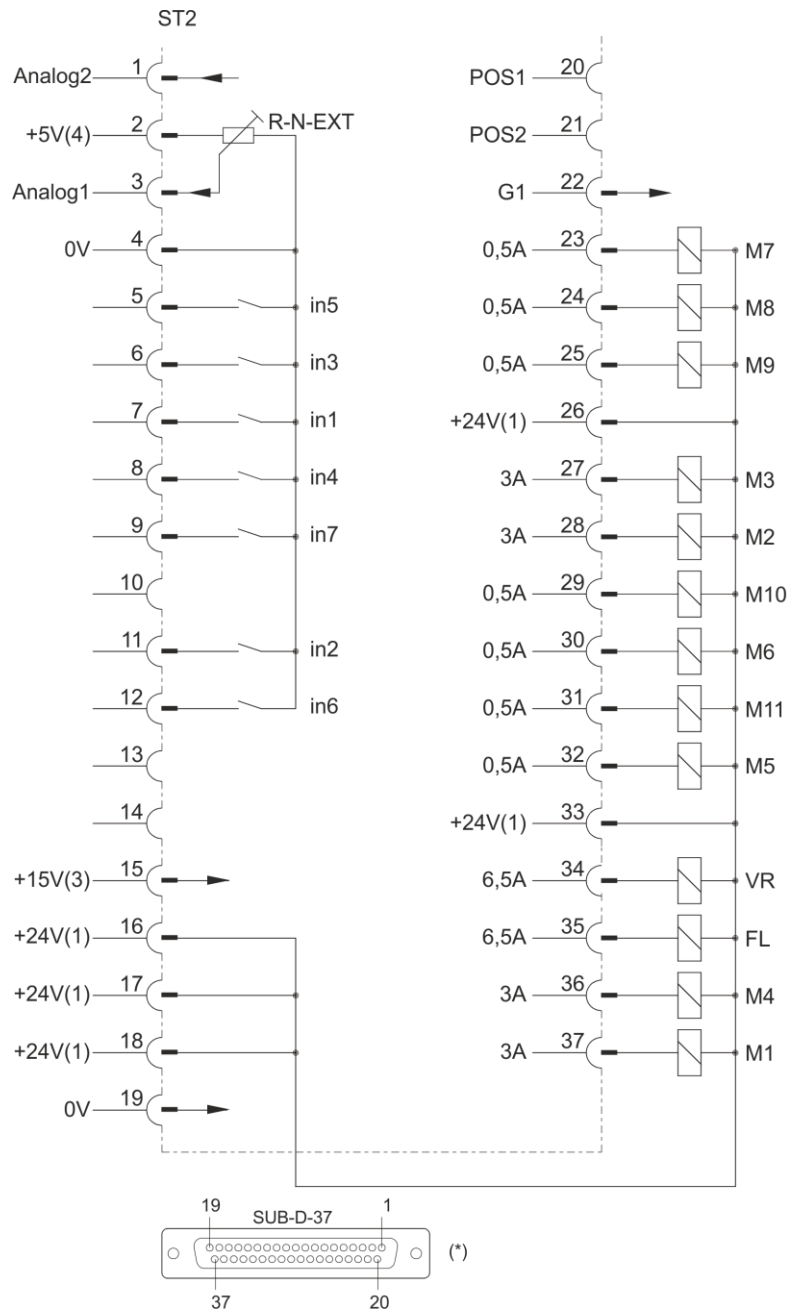

Bi2008a



ATTENTION

When connecting the outputs, ensure that a total power of 96VA constant load will not be exceeded!

in1	Input 1	R-N-EXT	External potentiometer for speed limitation	M4	Output 4
in2	Input 2	VR	Backtacking	M5	Output 5
in3	Input 3	POS1	Position 1	M6	Output 6
in4	Input 4	POS2	Position 2	M7	Output 7
in5	Input 5	FL	Sewing foot lifting	M8	Output 8
in6	Input 6	G1	Generator signal	M9	Output 9
in7	Input 7	M1	Output 1	M10	Output 10
		M2	Output 2	M11	Output 11
		M3	Output 3		

Inputs switched to +24 V

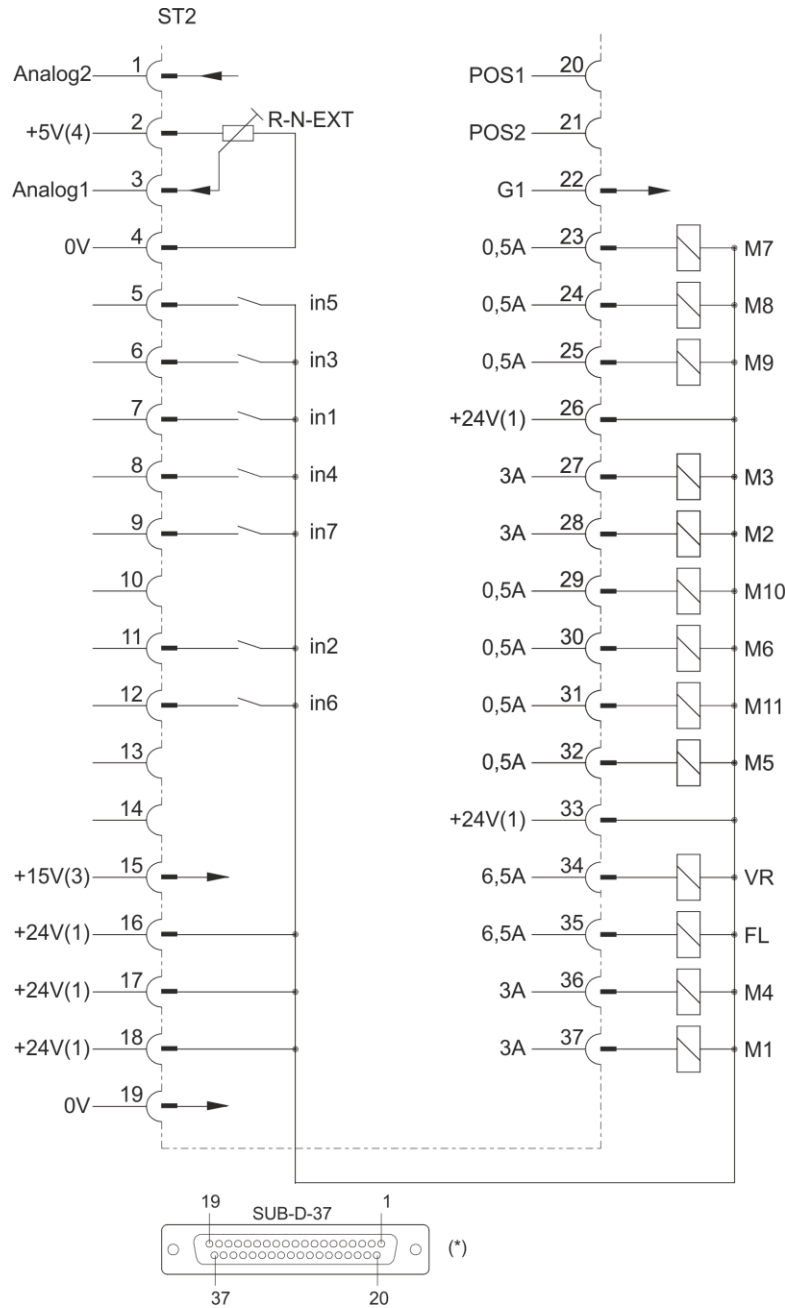

ATTENTION

When connecting the outputs, ensure that a total power of 96VA constant load will not be exceeded!

- 1) Nominal voltage +24 V, no-load voltage max. +30 V momentarily after power on
- 2) Transistor output with open collector max. +40 V, I_{max} 10 mA
- 3) Nominal voltage +15 V, I_{max} 30 mA
- 4) Nominal voltage +5 V, I_{max} 20 mA

*) View: Front view of the control (component side) and/or rear view of the outgoing connecting cable

Connection of a HSM001 Hall sensor module or an IPG001 pulse encoder

Connection of a light barrier module LSM002

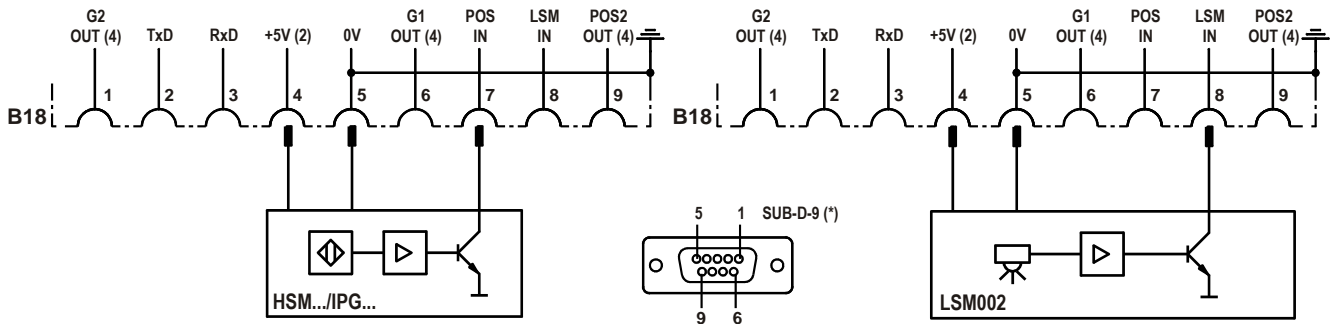

B1174a

Adapter cord 1113229 in case of multiple assignment of socket B18!

POS2 OUT	Output for position 2	LSM IN	Possibility of connecting a light barrier module to socket B18/8
POS IN	Input for positions (e. g. connection of a sensor)	LSM002	Reflection light barrier module
G1/G2 OUT	Output of generator impulses	HSM001	Hall sensor module
TXD/RXD	Serial transmission lines	IPG	Pulse encoder

If parameter 239 is set to >0, it is possible to operate a key at the input of the B18/8 connector.

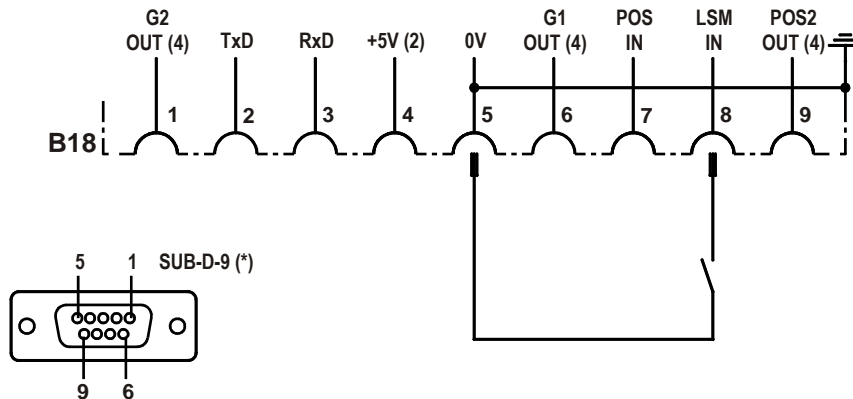

B1159a

There is a supply voltage of +5 V on the B18/4 socket for external devices. This voltage can be switched to +15 V using parameter 362.

⚠ ACHTUNG ⚠

When switching to +15 V, IPG and HSM001 can no longer connected to socket B18!

2) Nominal voltage +5V, I_{max} 100 mA (switchable to +15 V, I_{max} 100 mA)

4) Logic level output +5 V, I_{max} 5 mA

*) View: Front view of the control (component side) and/or rear view of the outgoing connecting cable

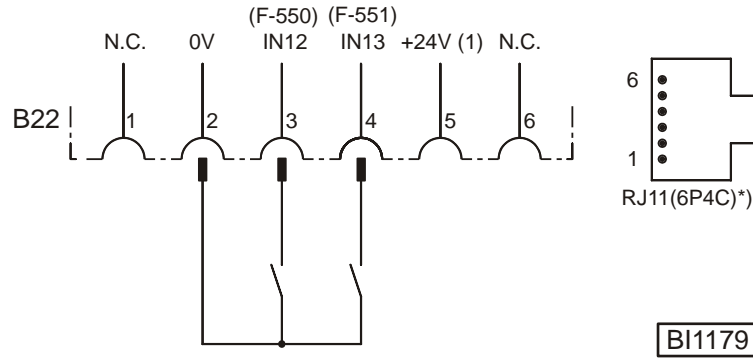

IN12	Input 12, function programmable using parameter 550	IN13	Input 13, function programmable using parameter 551
------	---	------	---

Connecting the analogous actuator EB401

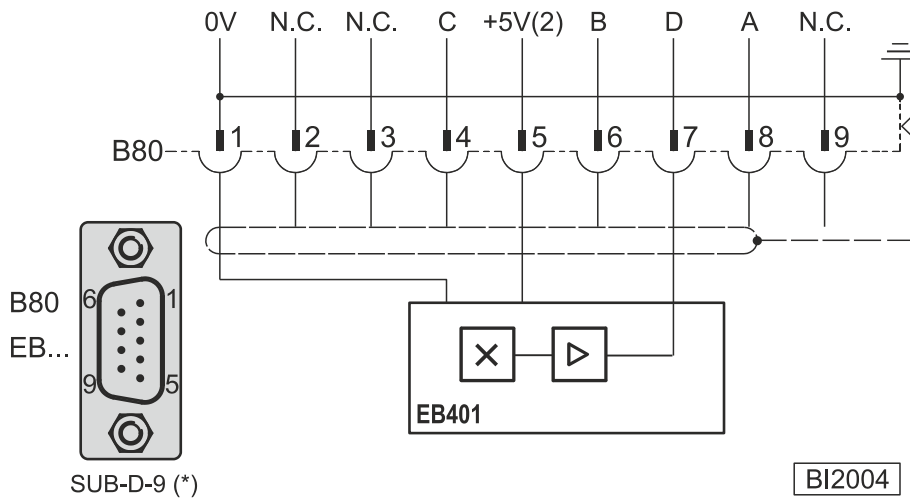

EB.. = Actuator

Code table for digital target value preset (grey code)

Pedal step →	-2	-1	0	½	1	2	3	4	5	6	7	8	9	10	11	12
Input A (B80/8)	L	L	H	H	H	L	L	H	H	L	L	H	H	L	L	H
Input B (B80/6)	L	H	H	L	L	L	H	H	H	L	L	L	L	L	H	H
Input C (B80/4)	H	H	H	H	L	L	L	L	L	L	L	L	H	H	H	H
Input D (B80/7)	H	H	H	H	H	H	H	H	L	L	L	L	L	L	L	L

Connection for frequency run

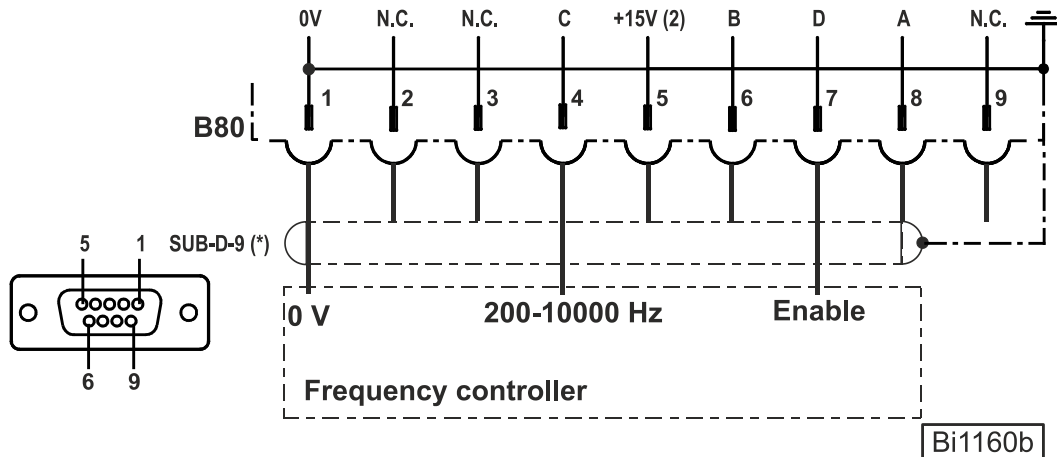

Connections: 0 V on Pin 1
 Frequency output on Pin 4
 Frequency controller output on Pin 7

In order to introduce motor running 0V must be applied to pin 7

Frequency rates: 0-5 V / 200-10000 Hz
 Min. speed 50 min⁻¹
 Max. speed F-111

Parameter F-396 =0 Frequency Off
 F-396 =1 Frequency On

Plug B80 input signal

Pin8 "A"	Pin6 "B"	Pin4 "C"	Pin5 "D"	Motor state
X	X	X	Deactivated.	Stop
X	X	Frequency < 60 Hz	Activated (0V)	Stop
X	X	Frequency > 60 Hz	Activated (0V)	Running
X	X	Frequency > 60 Hz	Deactivated.	Stop
0 V	0 V	X	Deactivated.	Trimmer

- 1) Nominal voltage +24 V, no-load voltage max. +30 V momentarily after power on
- 2) Nominal voltage +5 V, I_{max} 20 mA
- *) View: Front view of the control (component side) and/or rear view of the outgoing connecting cable

11 Timing Diagrams

Mode 0 (lockstitch)

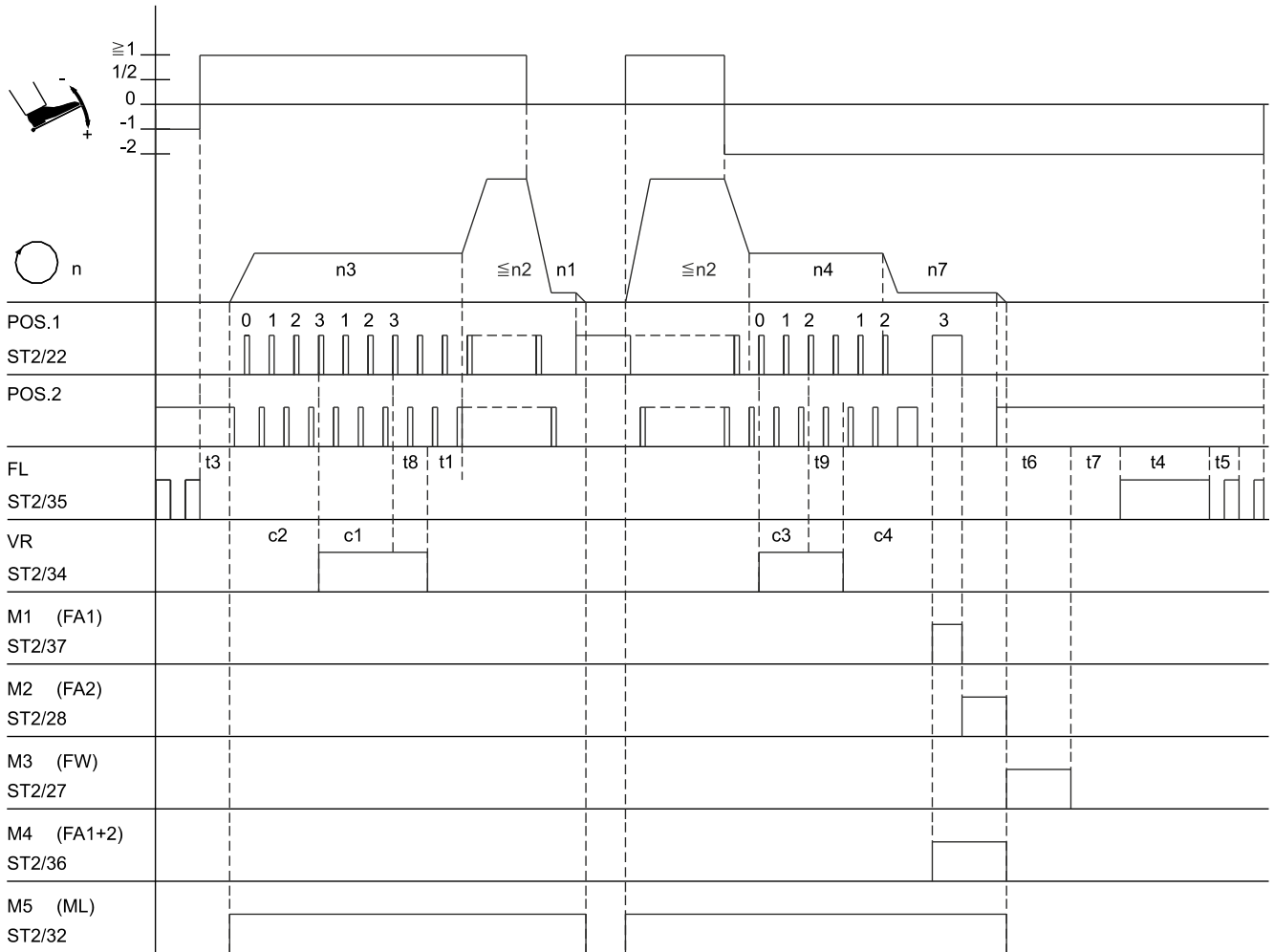

0330/MODE-00

Mark	Function	Parameters	Control	V810	V820
FAm	Mode 0	290 =0/27			
	Double start backtack with stitch correction	On	Key E	Key 1	Key 1
	Double end backtack with stitch correction	On	Key +	Key 2	Key 4
n1	Positioning speed	110			
n2	Maximum speed	111			
n3	Start backtack speed	112			
n4	End backtack speed	113			
n7	Trimming speed	116			
c2	Start backtack stitches forward	000			
c1	Start backtack stitches backward	001			
c3	End backtack stitches backward	002			
c4	End backtack stitches forward	003			
t8	Start backtack stitch correction	150			
t9	End backtack stitch correction	151			
t1	Delay until speed release after start backtack	200			
t3	Start delay from lifted sewing foot	202			
t4	Full power of sewing foot lifting	203			
t5	Pulsing of sewing foot lifting	204			
t6	Thread wiper ON period	205			
t7	Sewing foot switch-on delay after thread wiper	206			

Mode 2 (lockstitch)

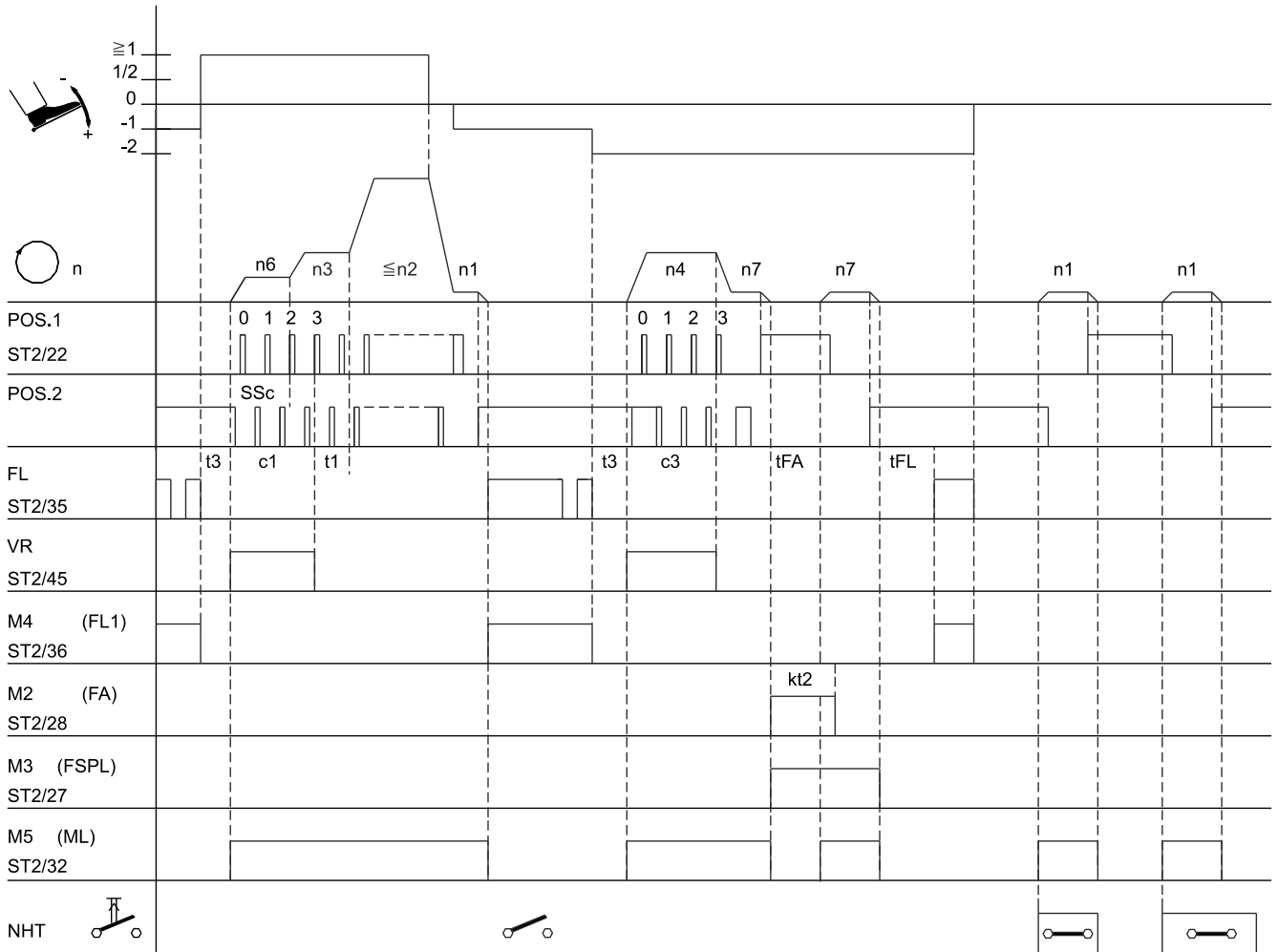

0330/MODE-02

Mark	Function	Parameters	Control	V810	V820
FAm	Mode 2	290 =2			
SSt	Softstart	134 =1			
	Single start backtack		Key E	Key 1	Key 1
	Single end backtack		Key +	Key 2	Key 4
n1	Positioning speed	110			
n2	Maximum speed	111			
n3	Start backtack speed	112			
n4	End backtack speed	113			
n6	Softstart speed	115			
n7	Trimming speed	116			
c1	Start backtack stitches backward	001			
c3	End backtack stitches backward	002			
SSc	Softstart stitches	100			
t1	Delay until speed release after start backtack	200			
t3	Start delay from lifted sewing foot	202			
tFL	Switch-on delay of sewing foot lifting	211			
tFA	Stopping time for thread trimming	253			
kt2	ON period thread trimmer	283			

Mode 3 (lockstitch)

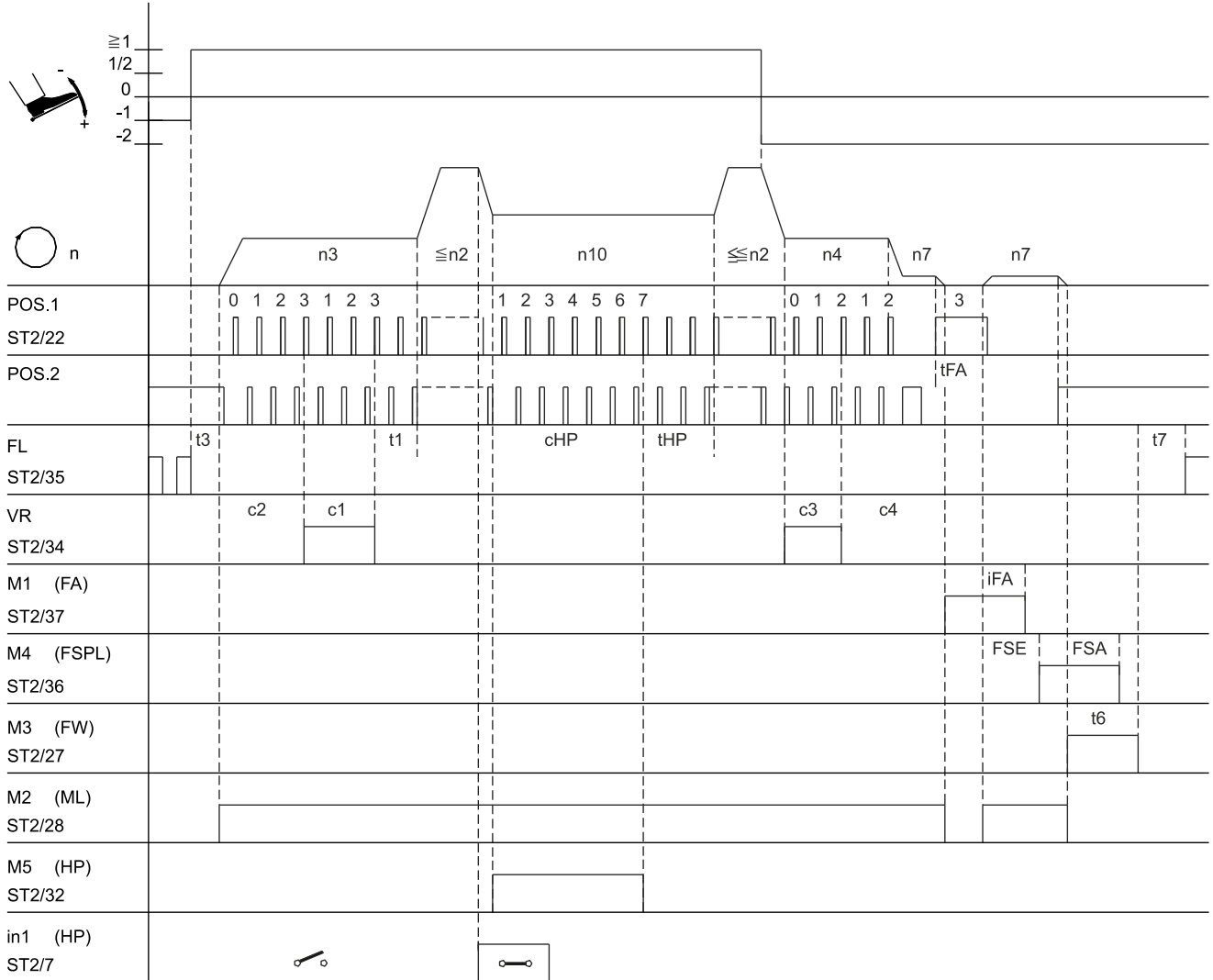

0330/MODE-03

Mark	Function	Parameters	Control	V810	V820
FAm	Mode 3	290 =3			
	Double start backtack		On		
	Double end backtack		On		
hP	High lift for walking foot	137 =1	Key E Key +	Key 1 Key 2	Key 1 Key 4
n2	Maximum speed	111			
n3	Start backtack speed	112			
n4	End backtack speed	113			
n7	Trimming speed	116			
n10	High lift walking speed	117			
c2	Start backtack stitches forward	000			
c1	Start backtack stitches backward	001			
c3	End backtack stitches backward	002			
c4	End backtack stitches forward	003			
thP	High lift walking speed run-out time	152			
chP	Stitch counting high lift for walking foot	185			
t6	Thread wiper ON period	205			
t7	Sewing foot switch-on delay after thread wiper	206			
iFA	Thread trimmer activation angle	250			
FSA	Switch-off delay of thread tension release	251			
FSE	Switch-on delay angle of thread tension release	252			
tFA	Stopping time for thread trimming	253			

Mode 5 (chainstitch)

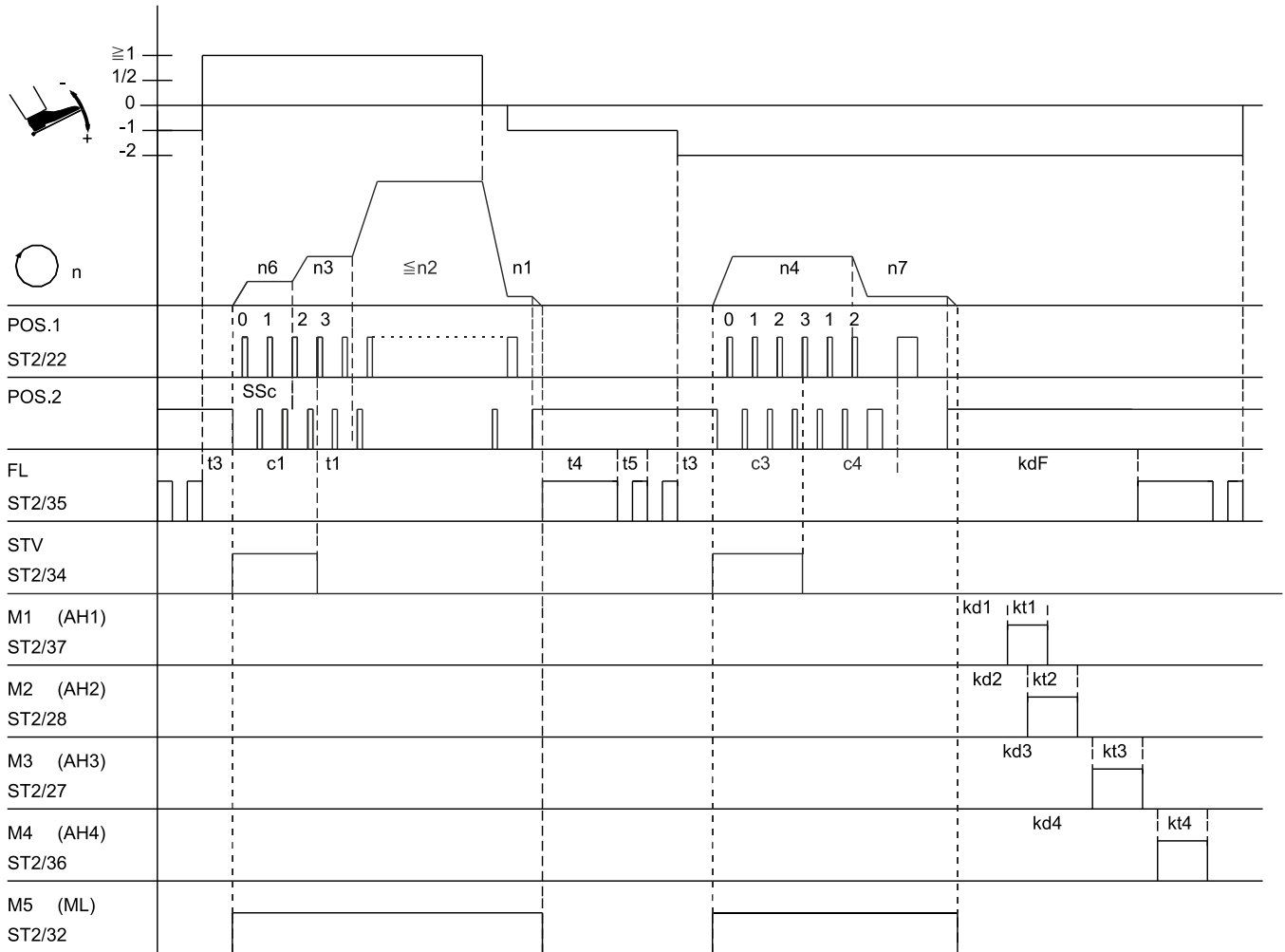

0330/MODE-05

Mark	Function	Parameters	Control	V810	V820
FAM SSt	Mode 5 Softstart Start stitch condensing End stitch condensing	290 =5 134 =1	Key E Key +	Key 1 Key 2	Key 1 Key 4
n1	Positioning speed	110			
n2	Maximum speed	111			
n3	Start stitch condensing speed	112			
n4	End stitch condensing speed	113			
n6	Softstart speed	115			
n7	Trimming speed	116			
c1	Stitch counting of start stitch condensing	001			
c3	Stitch counting of end stitch condensing	002			
c4	Stitch counting at the seam end without stitch regulator	003			
SSc	Softstart stitches	100			
t1	Delay until speed release after start backtack	200			
t3	Start delay from lifted sewing foot	202			
t4	Full power of sewing foot lifting	203			
t5	Pulsing of sewing foot lifting	204			
kdF	Switch-on delay of sewing foot lifting	288			
kd1-kd4	Delay times of outputs M1...M4	280/2/4/6			
kt1-kt4	ON periods of outputs M1...M4	281/3/5/7			

Mode 5, 6 or 7 (function “unlocking the chain” with light barrier)

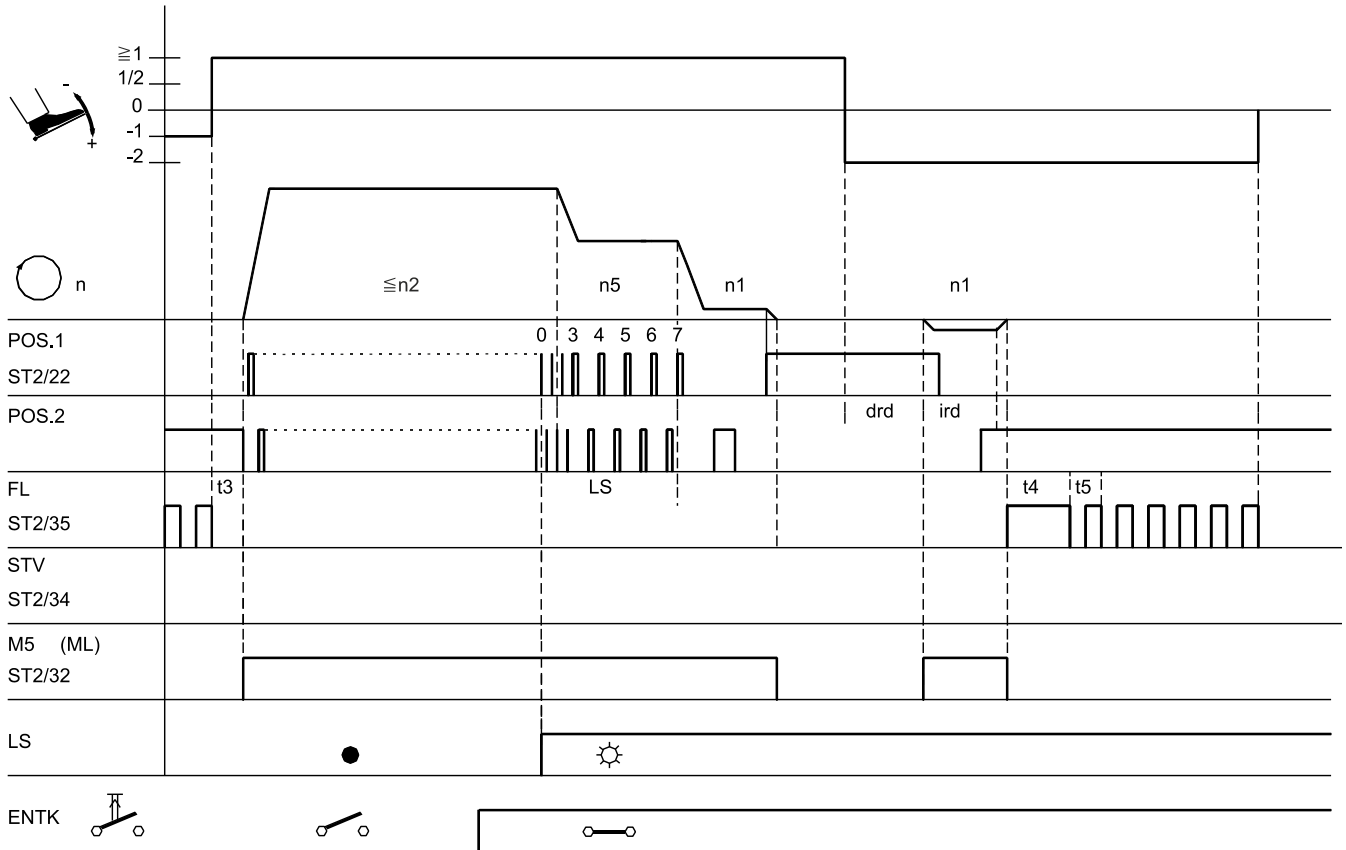

0330/ENTK-01

Mark	Function	Parameters	Control	V810	V820
FAm	Mode 5	290 =5			
drE	Direction of motor rotation	161 =0			
Frd	Reverse motor rotation	182 =1			
	Basic position 2		Key >>	Key 4	Key 7
	End stitch condensing and thread trimmer *)				
LS	Light barrier	009 =1			
mEk	Unlock the chain automatically with light barrier	190 =2			
in7	Machine run blockage effective with open	246 =6			
in8	contact	247 =10			
in..	Automatic speed n12 without pedal	2..			
	Assign the function “unlocking the chain” to an output				
n1	Positioning speed	110			
n2	Maximum speed	111			
n5	Speed after light barrier sensing	114			
LS	Light barrier compensating stitches	004			
ird	Number of reversing increments	180			
drd	Switch-on delay of reverse motor rotation	181			
t3	Start delay from lifted sewing foot	202			
t4	Full power of sewing foot lifting	203			
t5	Pulsing of sewing foot lifting	204			
tGn	Speed gate damping period	222			
dGF	Speed gate 2	224 =1			
kdF	Switch-on delay of sewing foot lifting	288			

*) When unlocking the chain, the functions “stitch condensing” and “thread trimmer” are suppressed!

Mode 5, 6 or 7 (function “unlocking the chain”)

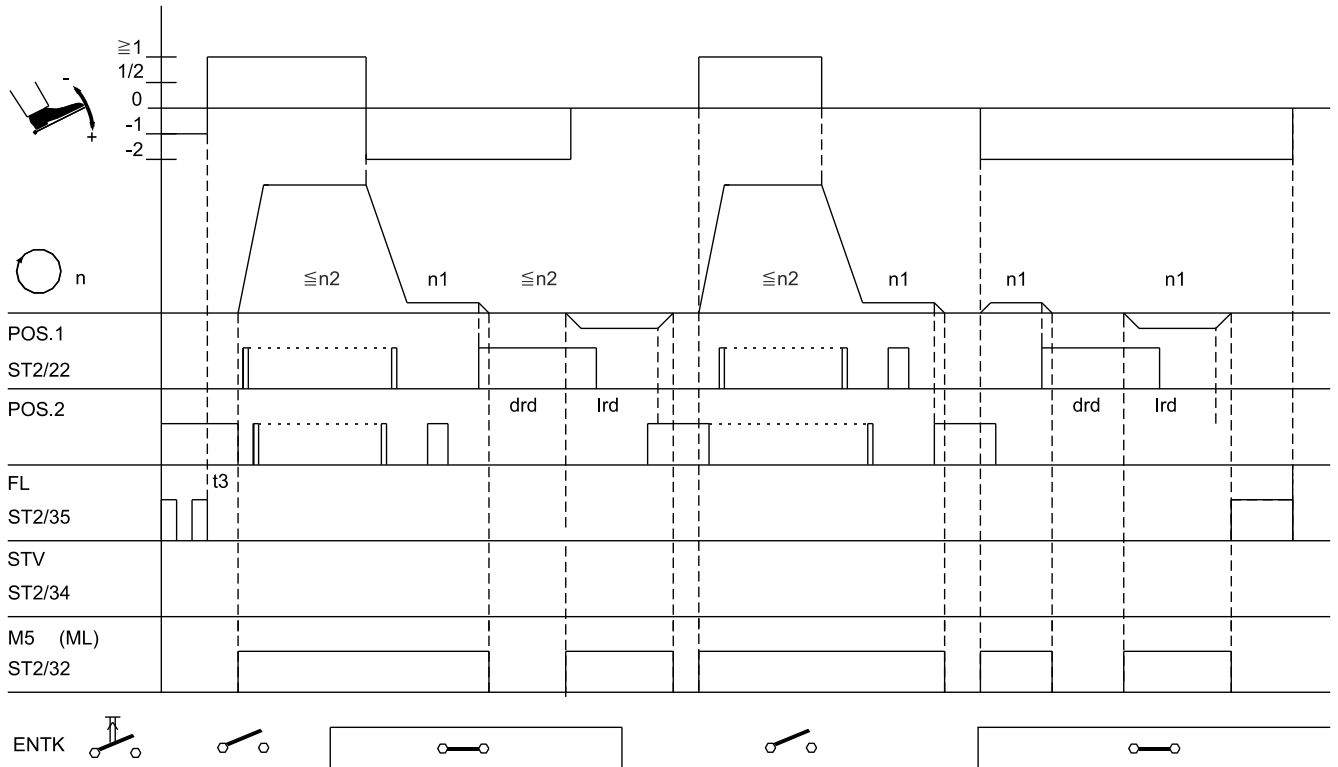

0330/ENTK-02

Mark	Function	Parameters	Control	V810	V820
FAm	Mode 5	290 =5			
drE	Direction of motor rotation	161 =0			
Frd	Reverse motor rotation	182 =1			
	Basic position 2		Key >>	Key 4	Key 7
	End stitch condensing and thread trimmer *)				
in7	Machine run blockage effective with open contact	246 =6			
in8		247 =10			
in..	Automatic speed n12 without pedal	2..			
	Assign the function “unlocking the chain” to an output				
n1	Positioning speed	110			
n2	Maximum speed	111			
ird	Number of reversing increments	180			
drd	Switch-on delay of reverse motor rotation	181			
t3	Start delay from lifted sewing foot	202			
t4	Full power of sewing foot lifting	203			
t5	Pulsing of sewing foot lifting	204			
tGn	Speed gate damping period	222			
dGF	Speed gate 2	224 =1			

*) When unlocking the chain, the functions “stitch condensing” and “thread trimmer” are suppressed!

Mode 6 (chainstitch with fast scissors) parameter 232 = 1

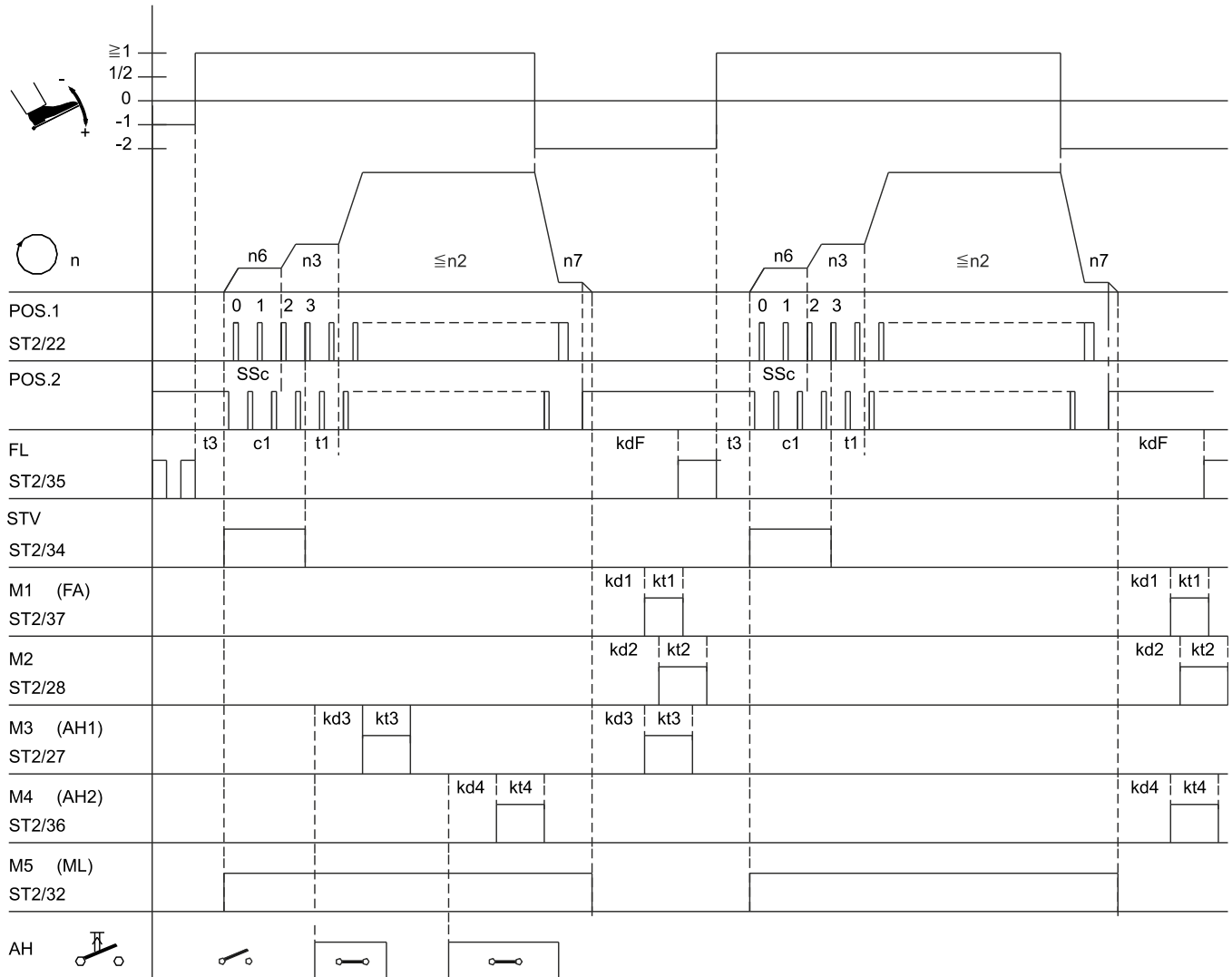

0330/MODE-06

Mark	Function	Parameters	Control	V810	V820
FAm	Mode 6	290 =6			
SSt	Softstart	134 =1			
USS	Start stitch condensing Chainstitch with fast scissors M3/M4	On 232 =1	Key E	Key 1	Key 1
n2	Maximum speed	111			
n3	Start stitch condensing speed	112			
n6	Softstart speed	115			
n7	Trimming speed	116			
c1	Stitch counting of start stitch condensing	001			
SSc	Softstart stitches	100			
t1	Delay until speed release after start backtack	200			
t3	Start delay from lifted sewing foot	202			
kd1/kd2	Delay times of outputs M1/M2	280 / 282			
kt1/kt2	ON periods of outputs M1/M2	281 / 283			
kd3/kd4	Delay times of outputs M3/M4 (AH1/AH2)	284 / 286			
kt3/kt4	ON periods of outputs M3/M4 (AH1/AH2)	285 / 287			
kdF	Switch-on delay of sewing foot lifting	288			

Mode 7 (overlock) parameter 232 = 0 (tape cutter) / parameter 018 = 0 (seam end with stop)

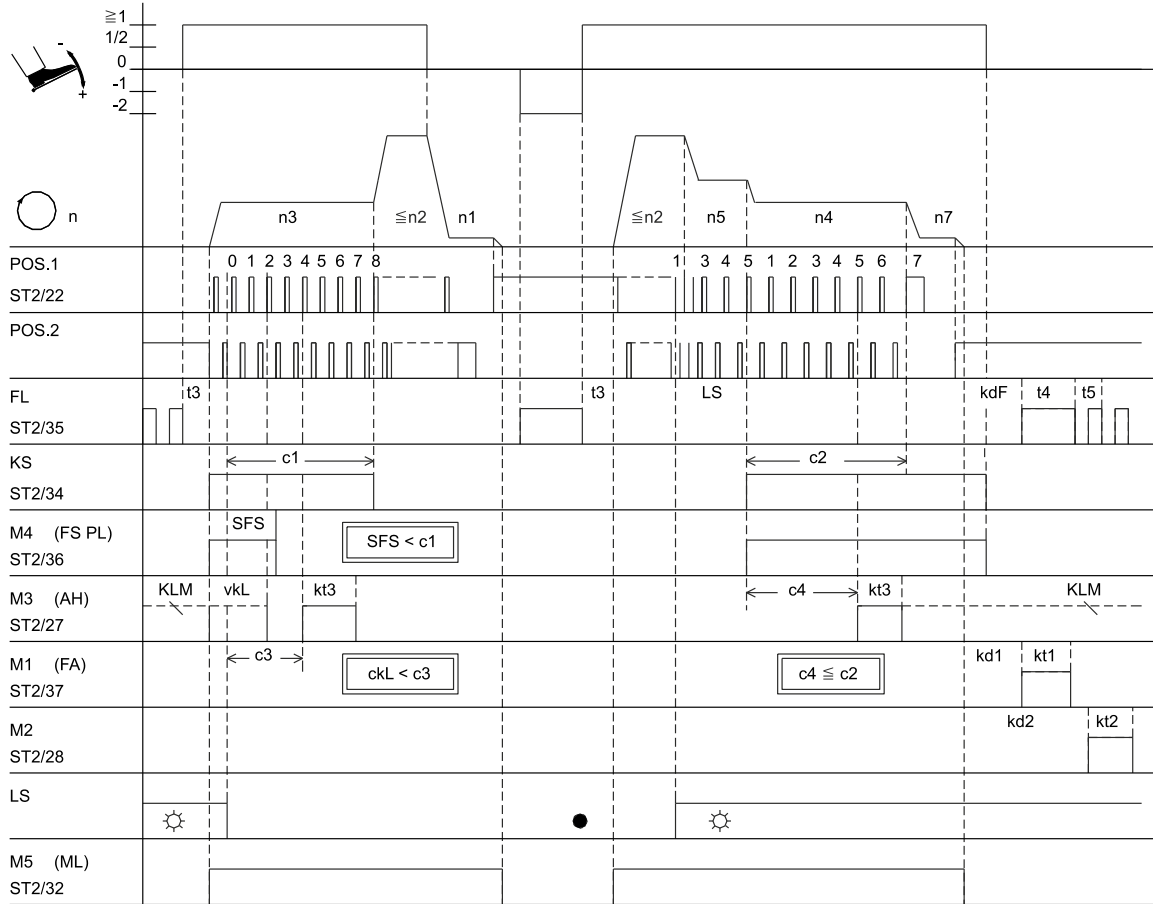

0330/MODE-07a

Mark	Function	Parameters	Control	V810	V820
FAm	Mode 7	290 = 7			
	Counts c1, c2, c3 and c4	On	Key E/+	Key 1/2	Key 1/4
	Sewing foot lifting at the seam end	On	Key -	Key 3	Key 6
LS	Light barrier	009 = 1			
UoS	Sequence "overlock mode with stop"	018 = 0			
-Pd	Function "pedal in pos. -2" blocked	019 = 2			
kLm	Clamp at the seam end	020 = 1			
SPO	Chain suction at the seam end until pedal in pos. 0 (neutral)	022 = 1			
tFS	Beginning of thread tension release at the start of the seam	025 = 0			
LSS	Start blockage with light barrier uncovered	132 = 0			
kSA	Stitch counting at the start of the seam at fixed speed n3	143 = 0			
kSE	Stitch counting at the seam end at fixed speed n4	144 = 0			
mhE	Seam end after count c2	191 = 1			
PLS	Speed n5 after light barrier sensing	192 = 0			
kSL	Chain suction On after light barrier compensating stitches	193 = 0			
USS	Tape cutter function	232 = 0			
n1	Positioning speed	110			
n2	Maximum speed	111			
n3	Speed for start counting	112			
n4	Speed for end counting	113			
n5	Speed after light barrier sensing	114			
n7	Trimming speed	116			
c2	End counting for chain suction	000			
c1	Start counting for chain suction	001			
c3	Start counting for tape cutter	002			
c4	End counting for tape cutter	003			
LS	Light barrier compensating stitches	004			
ckL	Run-out stitches clamp at the start of the seam	021			
SFS	Stitches from light barrier uncovered until end FSPL-E	157			
kd1/kd	Delay times of outputs M1/M	280/282			
kt1/kt2	ON periods of outputs M1/M2	281/283			
kt3	ON period of tape cutter	285			
kdF	Switch-on delay of sewing foot lifting	288			

Mode 7 (overlock) parameter 232 = 1 (fast scissors) / parameter 018 = 0 (seam end with stop)

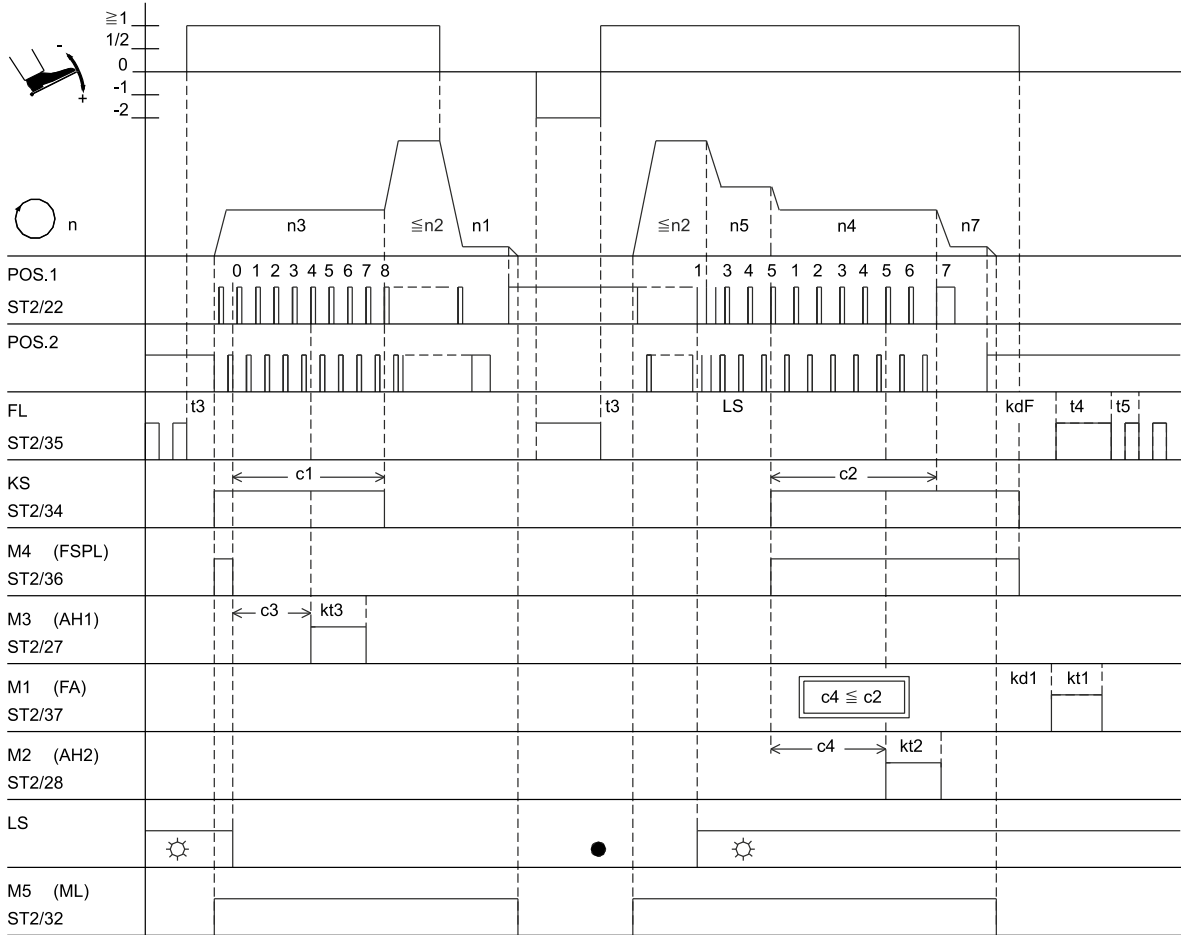

0330/MODE-07c

Mark	Function	Parameters	Control	V810	V820
FAm	Mode 7 Counts c1, c2, c3 and c4 Sewing foot lifting at the seam end	290 = 7 On	Key E/+ Key -	Key 1/2 Key 3	Key 1/4 Key 6
LS	Light barrier	009 = 1			
UoS	Sequence "overlock mode with stop"	018 = 0			
-Pd	Function "pedal in pos. -2" blocked	019 = 2			
kLm	Clamp at the seam end	020 = 0			
SPO	Chain suction at the seam end until pedal in pos. 0 (neutral)	022 = 1			
LSS	Start blockage with light barrier uncovered	132 = 0			
kSA	Stitch counting at the start of the seam at fixed speed n3	143 = 0			
kSE	Stitch counting at the seam end at fixed speed n4	144 = 0			
mhE	Seam end after count c2	191 = 1			
PLS	Speed n5 after light barrier sensing	192 = 0			
kSL	Chain suction On after light barrier compensating stitches	193 = 0			
USS	Function "fast scissors"	232 = 1			
n1	Positioning speed	110			
n2	Maximum speed	111			
n3	Speed for start counting	112			
n4	Speed for end counting	113			
n5	Speed after light barrier sensing	114			
n7	Trimming speed	116			
c2	End counting for chain suction	000			
c1	Start counting for chain suction	001			
c3	Start counting for tape cutter	002			
c4	End counting for tape cutter	003			
LS	Light barrier compensating stitches	004			
kd1	Delay time of output M1	280			
kd2	Delay time of output M2	282 = 0			
kt1/kt	ON periods of outputs M1/M2	281/283			
kt3	ON period of tape cutter	285			
kdF	Switch-on delay of sewing foot lifting	288			

Mode 7 (overlock) parameter 232 = 0 (tape cutter) / parameter 018 = 1 (seam end without stop)

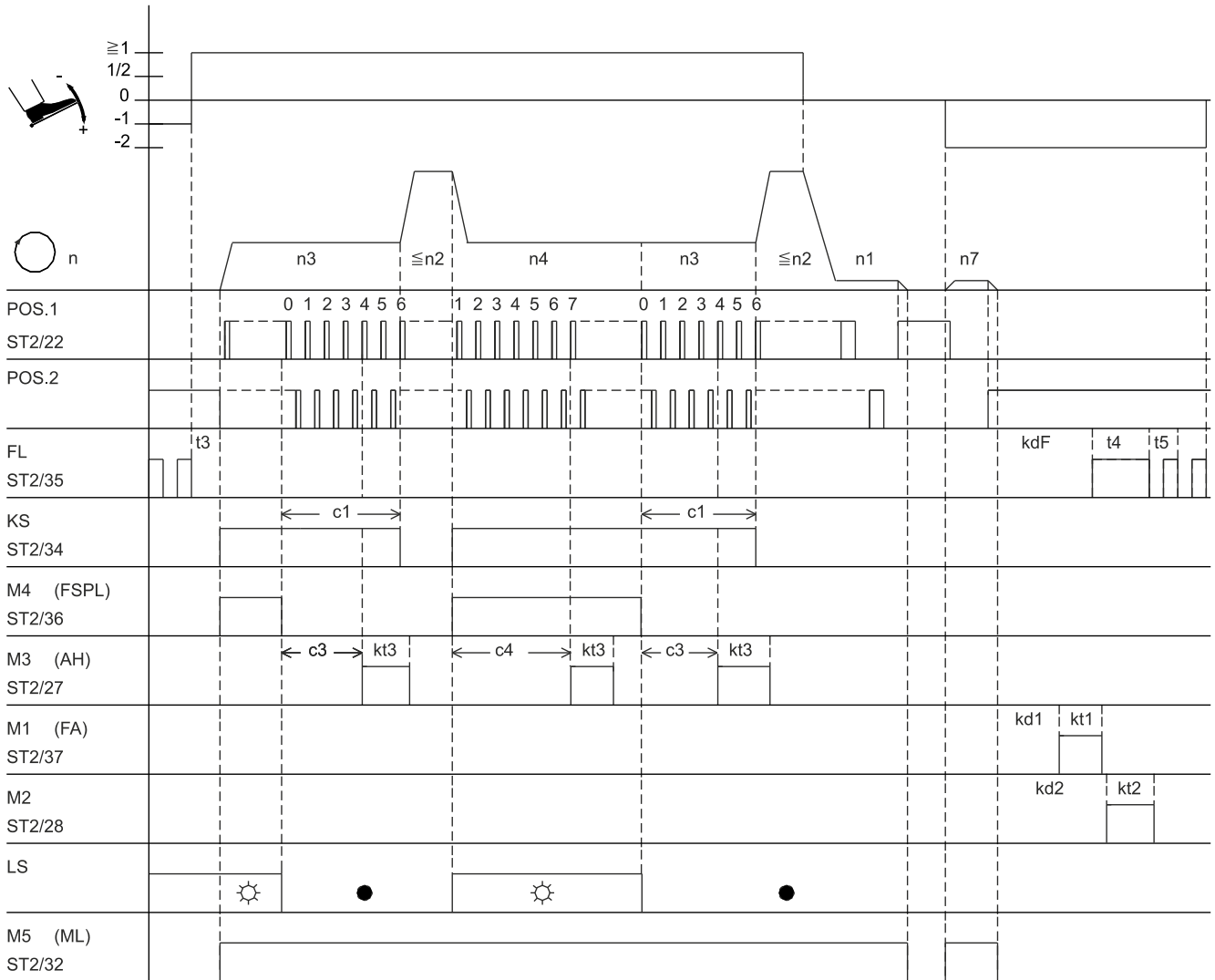

0330/MODE-07b

Mark	Function	Parameters	Control	V810	V820
FAm	Mode 7 Counts c1, c2, c3 and c4	290 = 7 On	Key E/+	Key 1/2	Key 1/4
LS	Light barrier compensating stitches	004 = 0			
LS	Light barrier	009 = 1			
UoS	Sequence "overlock mode at the seam end without stop"	018 = 1			
-Pd	Function "pedal in pos. -1/-2" activated in the seam	019 = 3			
SPO	Chain suction at the seam end until pedal in pos. 0 (neutral)	022 = 1			
kSA	Stitch counting at the start of the seam at fixed speed n3	143 = 1			
kSE	Stitch counting at the seam end at fixed speed n4	144 = 1			
USS	Tape cutter function	232 = 0			
n1	Positioning speed	110			
n2	Maximum speed	111			
n3	Speed for start counting	112			
n7	Trimming speed	116			
c1	Start counting for chain suction	001			
c3	Start counting for tape cutter	002			
c4	End counting for tape cutter	003			
t3	Start delay from lifted sewing foot	202			
kd1/kd2	Delay times of outputs M1/M2	280/282			
kt1/kt2	ON periods of outputs M1/M2	281/283			
kt3	ON period of tape cutter	285			
kdF	Switch-on delay of sewing foot lifting	288			

Mode 7 (overlock) chain suction permanent signal

Parameter F-155= 1
 Parameter F-156= 200 ms
 Suction always On if motor running signal

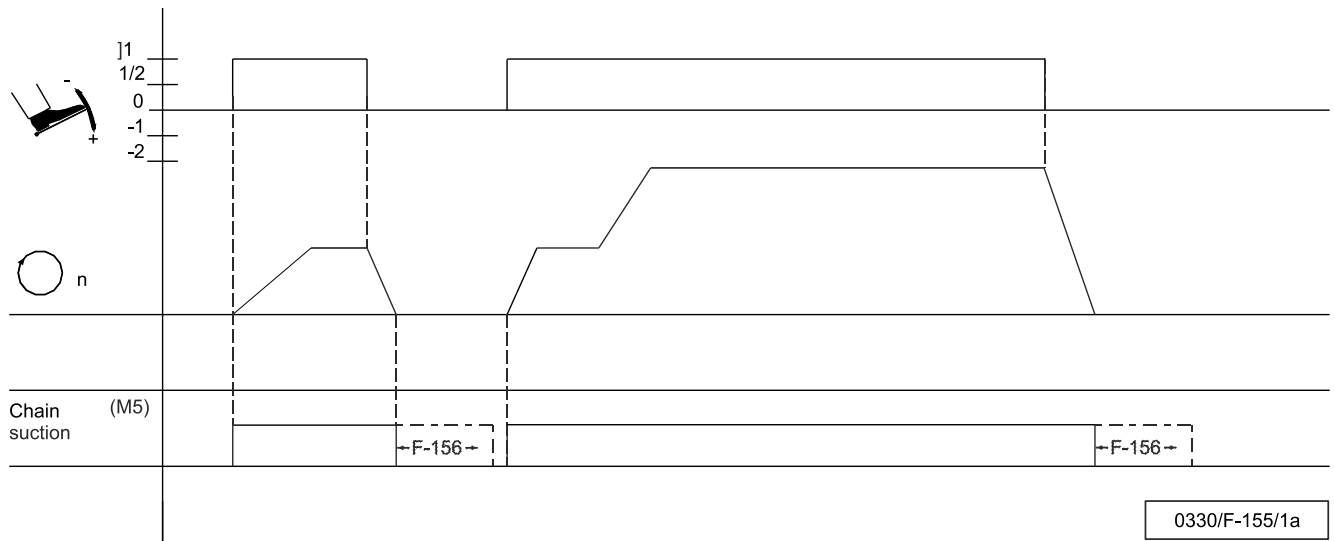

Mark	Function	Parameters			
M5	Chain suction	155 = 1			
n	Speed				
F-156	Switch-off delay for M2	156 = 200ms			

Mode 7 (overlock) chain suction via stitch count (Ecco)

Parameter F-155= 5
 Parameter F-084= 5
 Parameter F-085= 4

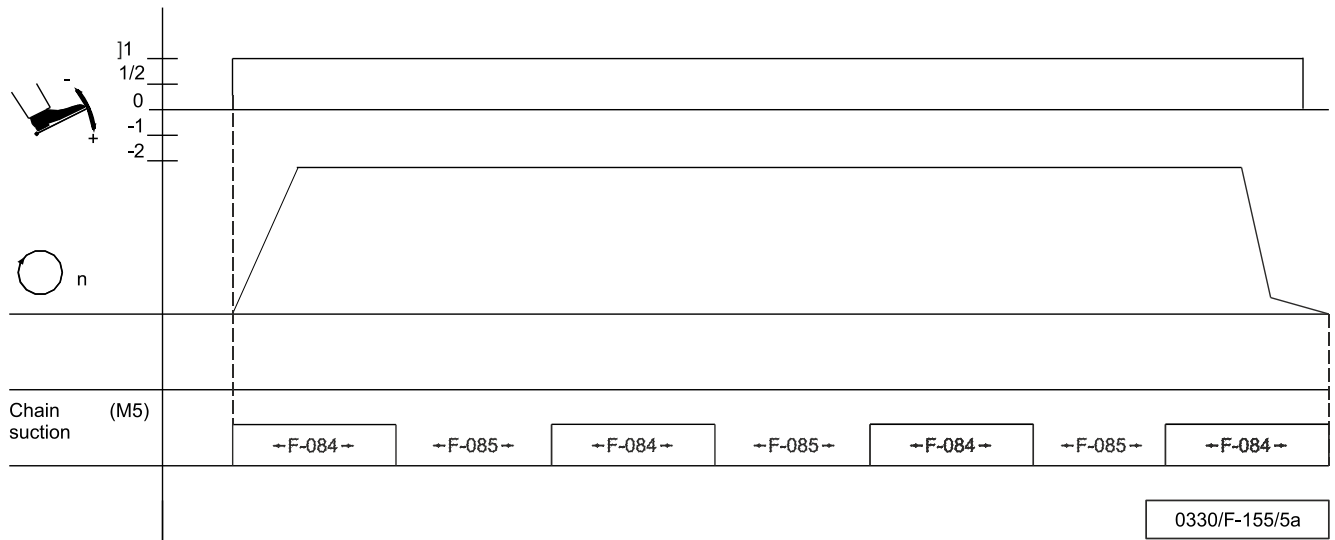

Mark	Function	Parameters
M5	Chain suction	155 = 5
n	Speed	
Mle	Stitches for motor run Ecco On	084 = 5
Mla	Stitches for motor run Ecco Off	085 = 4

Mode 7 (overlock) Chain suction controlled via light barrier

Parameter F-155= 6

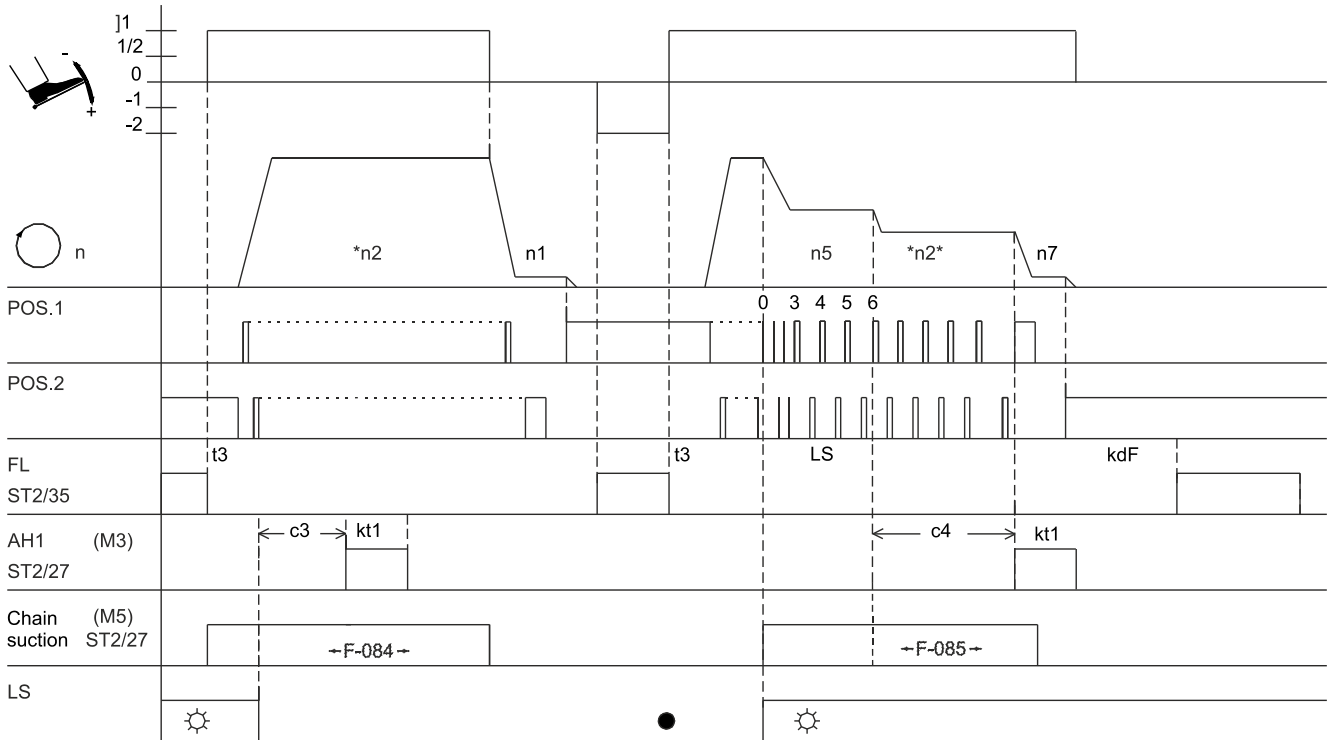

0330/F-155/6a

Mark	Function	Parameters	Control		
LS	Sewing foot lifting at the seam end	On			
UoS	Light barrier		Key -		
-Pd	Sequence "overlock mode with stop"	009 =1			
LSS	Function "pedal in pos. -2" blocked	018 =0			
PLS	Start blockage with light barrier uncovered	019 =2			
USS	Speed n5 after light barrier sensing	192 =0			
n1	Tape cutter function	232 =0			
n1	Positioning speed	110			
n2	Maximum speed	111			
n5	Speed after light barrier sensing	114			
n7	Trimming speed	116			
c3	Start counting for tape cutter	002			
c4	End counting for tape cutter	003			
LS	Light barrier compensating stitches	004			
kt1	ON period of tape cutter	281			
kdF	Switch-on delay of sewing foot lifting	288			
Mle	Run-out stitch chain suction on seam start	084			
Mla	Run-out stitch chain suction on seam end	085			

Mode 7 (overlock) chain suction controlled via light barrier and chain suction signal interrupted during stop

Parameter F-155= 7

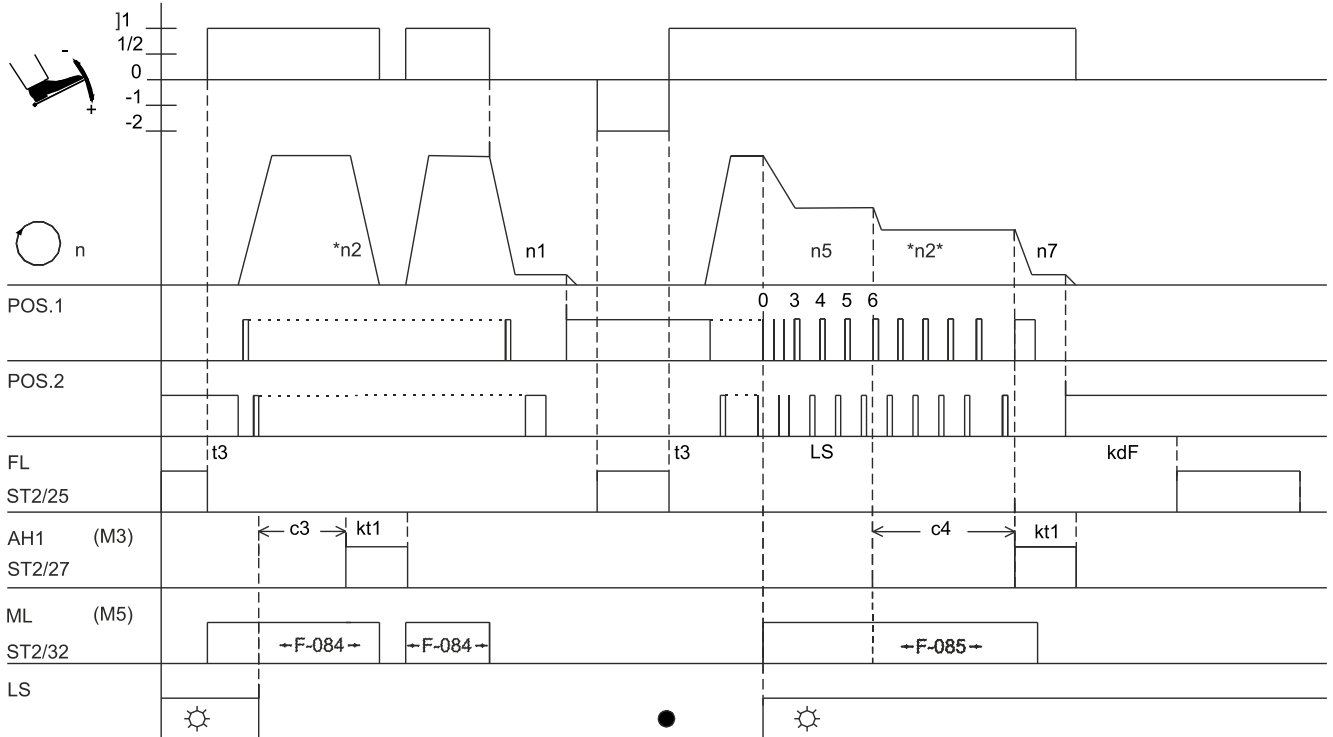

0330/F-155/7a

Mark	Function	Parameters	Control
LS	Sewing foot lifting at the seam end	On	
UoS	Light barrier	009 =1	Key -
-Pd	Sequence "overlock mode with stop"	018 =0	
LSS	Function "pedal in pos. -2" blocked	019 =2	
PLS	Start blockage with light barrier uncovered	192 =0	
USS	Speed n5 after light barrier sensing	232 =0	
	Tape cutter function		
n1	Positioning speed	110	
n2	Maximum speed	111	
n5	Speed after light barrier sensing	114	
n7	Trimming speed	116	
c3	Start counting for tape cutter	002	
c4	End counting for tape cutter	003	
LS	Light barrier compensating stitches	004	
kt1	ON period of tape cutter	281	
kdF	Switch-on delay of sewing foot lifting	288	
Mle	Run-out stitch chain suction on seam start	084	
Mla	Run-out stitch chain suction on seam end	085	

Mode 8 (backlatch Pegasus)

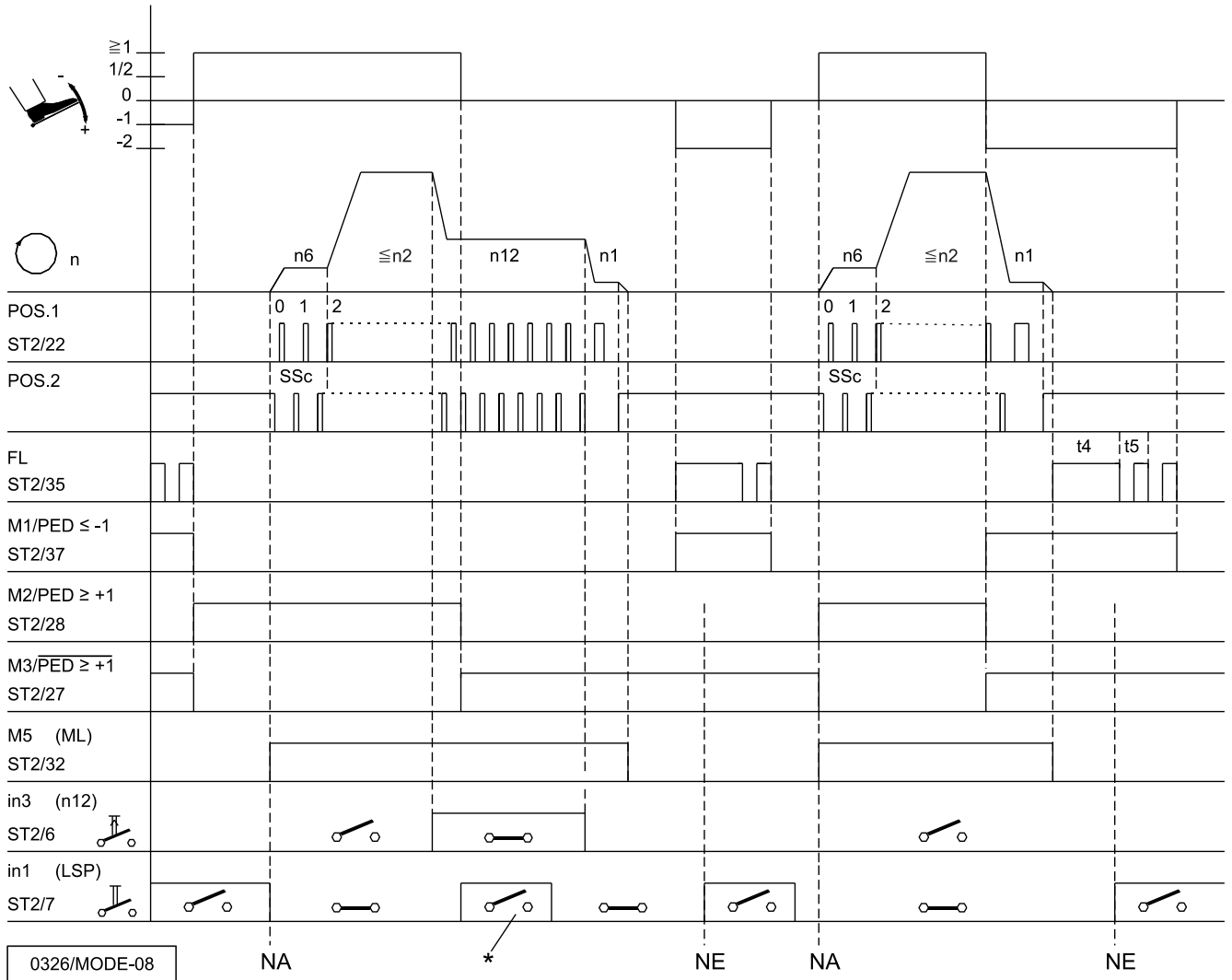

Mark	Function	Parameters	Control	V810	V820
FAm	Mode 8	290 =8			
	Basic position 2	On	Key >>	Key 4	Key 7
SSt	Softstart	134 =1			
in1	Machine run blockage activated with open switch	240 =6			
in3	n-Auto with closed switch	242 =10			
n1	Positioning speed	110			
n2	Maximum speed	111			
n6	Softstart speed	115			
n12	Automatic speed	118			
SSc	Softstart stitches	100			
t4	Full power of sewing foot lifting	203			
t5	Pulsing of sewing foot lifting	204			

*) When automatic speed is On, machine run blockage (safety switch) does not work!

NA Start of seam

NE Seam end

Mode 9 (backlatch Yamato)

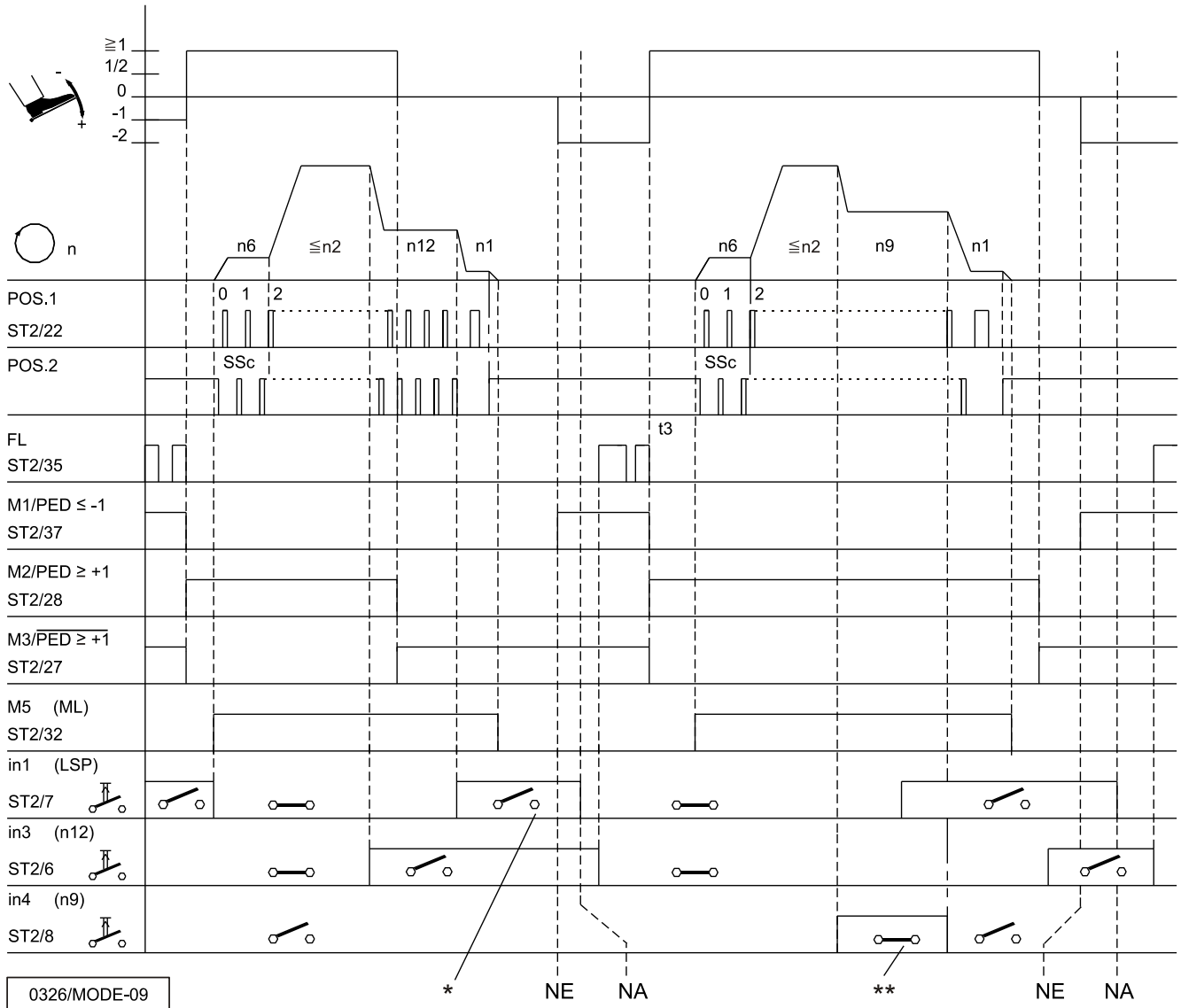

Mark	Function	Parameters	Control	V810	V820
FAm	Mode 9	290 =9	Key >>	Key 4	Key 7
SSSt	Softstart	134 =1			
in1	Machine run blockage activated with open switch	240 =6			
in3	Automatic speed on an open switch (The function of input 3 is inverted in mode 9)	242 =10			
PGm	Setting an external sensor to position 2. (A sensor must be connected!)	270			
n1	Positioning speed	110			
n2	Maximum speed	111			
n6	Softstart speed	115			
n9	Limited speed n9	122			
n12	Automatic speed	118			
SSc	Softstart stitches	100			
t3	Start delay from lifted sewing foot	202			
t4	Full power of sewing foot lifting	203			
t5	Pulsing of sewing foot lifting	204			

*) With this setting, machine run blockage (safety switch) takes priority over automatic speed!

**) Automatic speed n9 takes priority over machine run blockage (safety switch)!

NA Start of seam

NE Seam end

Mode 14 (lockstitch)

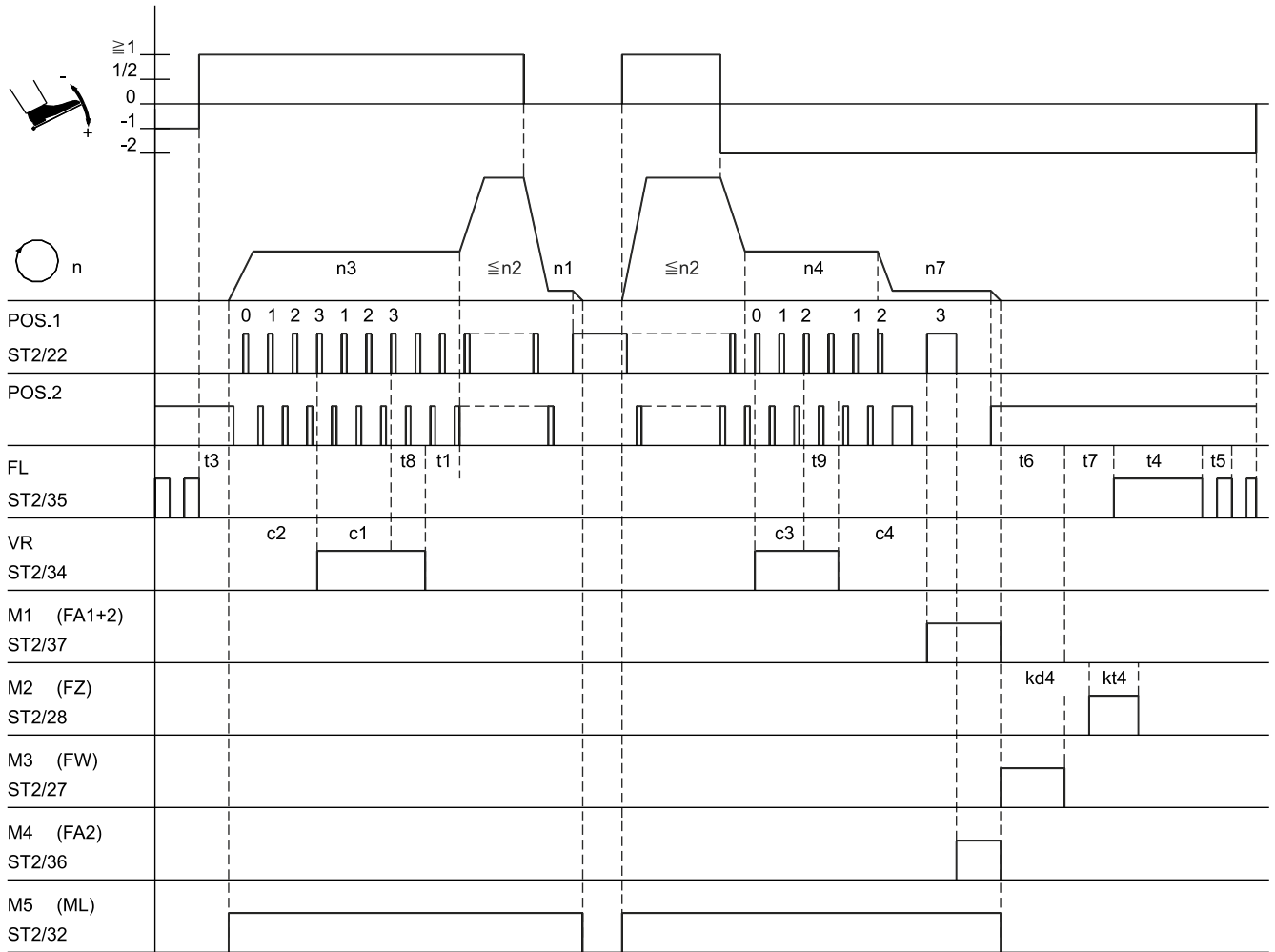

0330/MODE-14

Mark	Function	Parameters	Control	V810	V820
FAm	Mode 14	290=14			
	Double start backtack with stitch correction	On	Key E	Key 1	Key 1
	Double end backtack with stitch correction	On	Key +	Key 2	Key 4
PGm	Setting an external sensor to position 1. (A sensor must be connected!)	270=3			
n1	Positioning speed	110			
n2	Maximum speed	111			
n3	Start backtack speed	112			
n4	End backtack speed	113			
n7	Trimming speed	116			
c2	Start backtack stitches forward	000			
c1	Start backtack stitches backward	001			
c3	End backtack stitches backward	002			
c4	End backtack stitches forward	003			
t8	Start backtack stitch correction	150			
t9	End backtack stitch correction	151			
t1	Delay until speed release after start backtack	200			
t3	Start delay from lifted sewing foot	202			
t4	Full power of sewing foot lifting	203			
t5	Pulsing of sewing foot lifting	204			
t6	Thread wiper ON period	205			
t7	Sewing foot switch-on delay after thread wiper	206			
kd4	Delay time output M2	286			
kt4	ON period output M2	287			

Mode 17 (Stitchlock Pegasus)

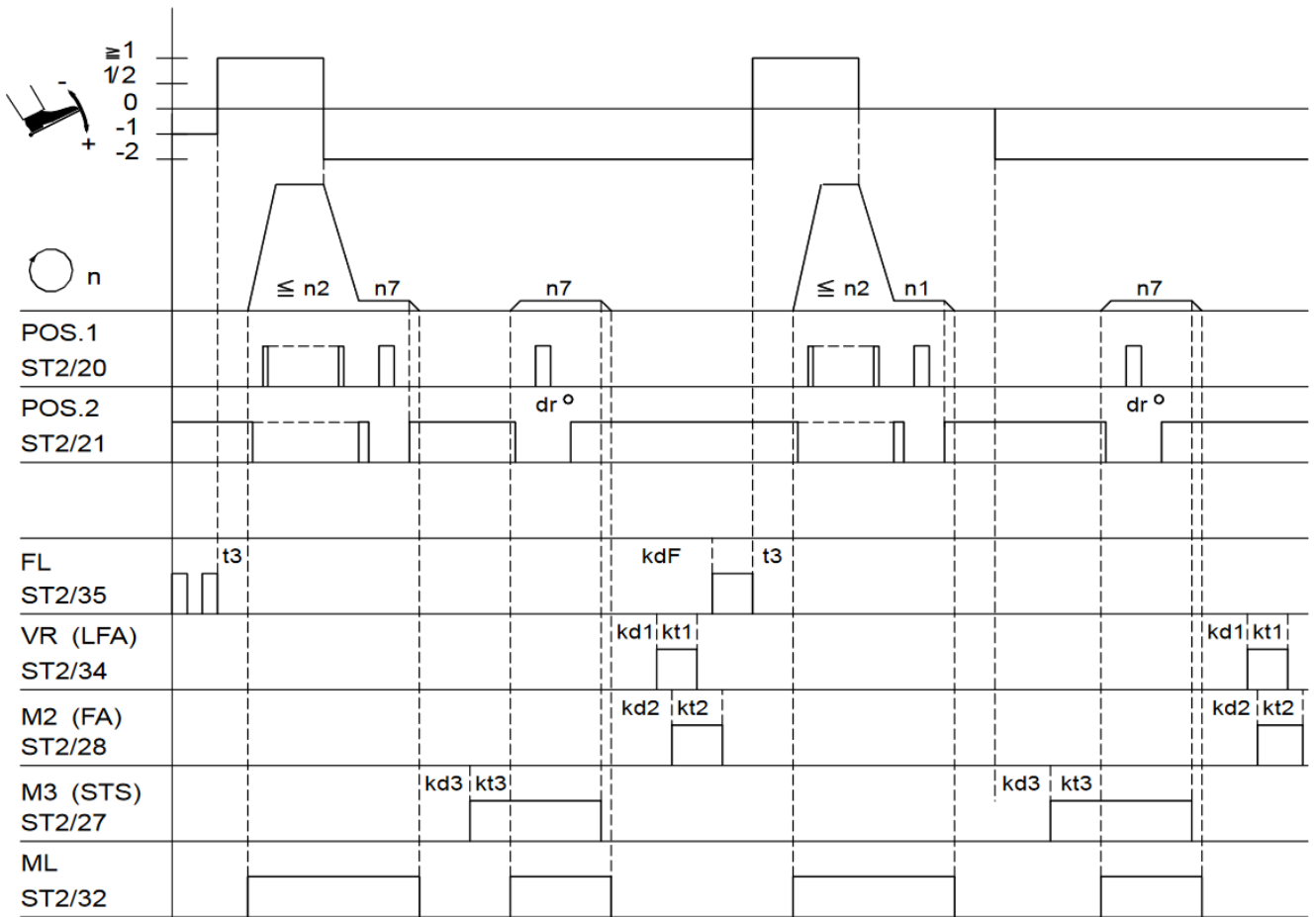

0256/ MODE- 17

Mark	Function	Parameter	Control	V810	V820/V850
FAm	Mode 17 Positon 2 Trimmer and Thread wiper	290=17 ON ON	Button S5 Button S2	Button 4	Button 7 Button 5
n1	Positioning speed	110			
n2	Maximum speed	111			
n7	Trimming speed	116			
dr°	Angle dependent Stopp for trimmer	197			
t3	Delay from sewing foot lifting	202			
kd1	Delay time until trimmer LFA	280			
kt1	On periods of des Lege trimmer LFA	281			
kd2	Delay time until Trimmer FA ON	282			
kt2	On periods of trimmer FA	283			
kd3	Delay of Stitchlock function STS	284			
kt3	On periods of Stitchlock-function STS	285			
kdF	Delay time until sewing foot On	288			

Mode 21 (Stitchlock Yamato)

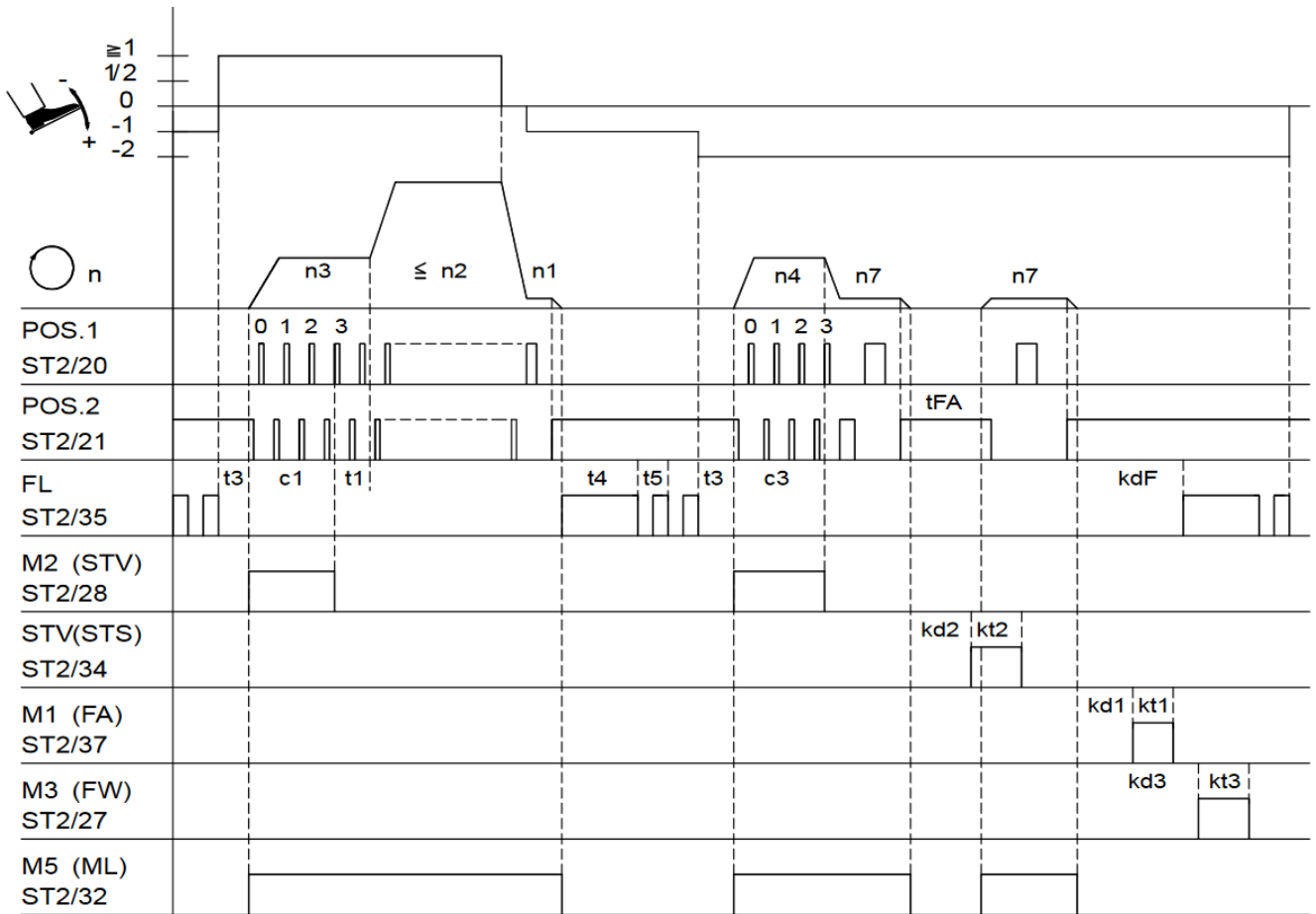

0256/ MODE- 21

Mark	Function	Parameter	Control	V810	V820/V850
FAm	Mode 21	290 = 21			
StL	Stitchlock-Function	ON	Button S2	Button 1	Button 1
	Start backtack	ON	Button S3	Button 2	Button 4
	End backtack				
PGm	Setting an external sensor to position 2. (A sensor must be connected!)	270 = 1			
n1	Positioning speed	110			
n2	Maximum speed	111			
n3	Start backtack speed	112			
n4	End backtack speed	113			
n7	Trimming speed	116			
c1	Counter start backtack	001			
c3	Counter end backtack	002			
t1	Delay until speed release after start backtack	200			
t3	Start delay from lifted sewing foot	202			
t4	Full power of sewing foot lifting	203			
t5	Pulsing of sewing foot lifting	204			
tFA	Stopping time for thread trimming	253			
kd1	Delay time of output M1	280			
kt1	On periods of output M1	281			
kd2	Delay time of output M2	282			
kt2	On periods of output M2	283			
kd3	Delay thread wiper	284			
kt3	On periods of thread wiper	285			
kdF	Delay time until sewing foot On	288			

Mode 25 (lockstitch Juki LU2210 / LU2260)

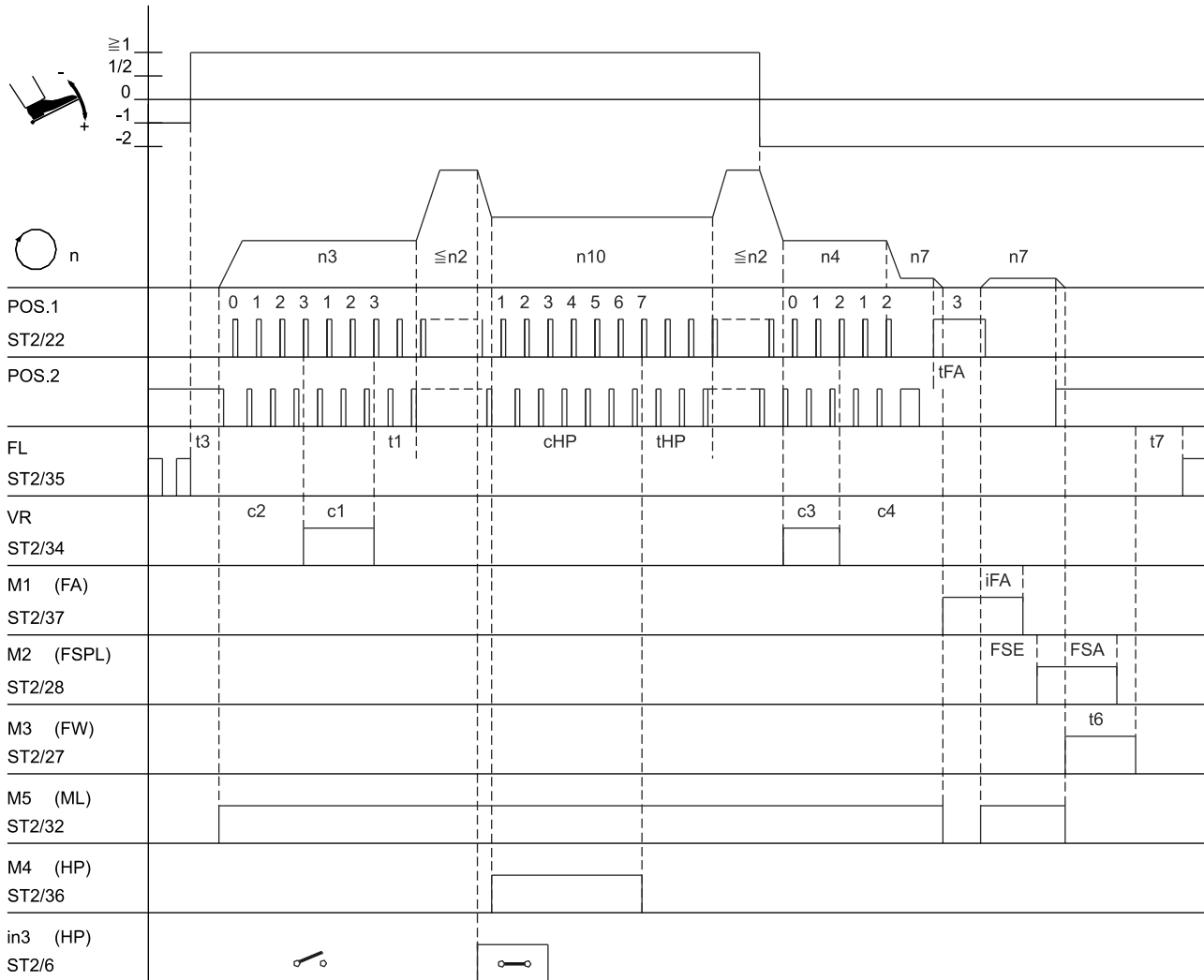

0330/MODE-25

Mark	Function	Parameters	Control	V810	V820
FAm	Mode 25	290 =25			
	Double start backtack	On	Key E	Key 1	Key 1
	Double end backtack	On	Key +	Key 2	Key 4
Pot	External potentiometer is active				
hP	High lift for walking foot	126 =3			
in3	High lift for walking foot with speed limitation n10	137 =1			
PGm	Setting an external sensor to position 1. (A sensor must be connected!)	242 =14 270 =3			
n2	Maximum speed	111			
n3	Start backtack speed	112			
n4	End backtack speed	113			
n7	Trimming speed	116			
n10	High lift walking speed	117			
c2	Start backtack stitches forward	000			
c1	Start backtack stitches backward	001			
c3	End backtack stitches backward	002			
c4	End backtack stitches forward	003			
thP	High lift walking speed run-out time	152			
chP	Stitch counting high lift for walking foot	185			
t1	Start backtack until speed release after start backtack	200			
t3	Start start backtack from lifted sewing foot	202			
t6	Thread wiper ON period	205			
t7	Sewing foot switch-on start backtack after thread wiper	206			
iFA	Thread trimmer activation angle	250			
FSA	Switch-off start backtack of thread tension release	251			
FSE	Switch-on start backtack angle of thread tension release	252			
tFA	Stopping time for thread trimming	253			

11.1 Operator Level

Note The preset values indicated apply to mode 0 (Parameter 290 = 0).

For preset values applicable to other modes see table in chapter 11.1 »Preset Values Depending on Mode«.

Parameters	Designation	Unit	Max	Min	Preset	Ind.
000	c2 - Number of stitches of start backtack forward - Number of stitches of start stitch condensing without stitch regulator - Number of stitches of end counting chain suction	Stitches	254	0	2	
001	c1 - Number of stitches of start backtack backward - Number of stitches of start stitch condensing with stitch regulator - Number of stitches of start counting chain suction	Stitches	254	0	4	
002	c3 - Number of stitches of end backtack backward - Number of stitches of end stitch condensing with stitch regulator - Number of stitches of tape cutter at the start of the seam	Stitches	254	0	2	
003	c4 - Number of stitches of end backtack forward - Number of stitches of end stitch condensing without stitch regulator - Number of stitches of tape cutter at the seam end	Stitches	254	0	2	
004	LS Light barrier compensating stitches	Stitches	254	0	7	
005	LSF Number of stitches of the light barrier filter for knitted fabrics	Stitches	254	0	1	
006	LSn Number of light barrier seams		15	1	1	
007	Stc Number of stitches for the seam with stitch counting	Stitches	999	0	20	
008	-F A parameter from the technician level is assigned to key 9 on the V820 control panel 1 = Softstart On/Off 2 = Ornamental backtack On/Off 3 = Start of sewing blocked with light barrier uncovered On/Off 4 = Unlocking the chain On/Off 8 = Backtack repetition On/Off 9 = Multi-backtack / standard backtack		9	1	1	
009	LS Light barrier On/Off		1	0	0	
010	SrM Strobrel backtack in mode F-290 =56 0 = End backtack off 1 = Single end backtack on 2 = Double end backtack on 3 = Double start and double end backtack on 4 = Simple start backtack and simple end tack on		4	0	0	F
013	FA Thread trimmer On/Off		1	0	0	
014	Fw Thread wiper On/Off		1	0	0	
015	StS Stitch counting On/Off		1	0	0	
017	SAb Stop for tape cutting at the seam end On/Off (Function only when overlock mode is active).		1	0	0	
018	UoS 0 = Sequence "overlock mode with stop" 1 = Sequence "overlock mode without automatic stop. When the command "run" is given, the drive runs at the pre-selected speed. With pedal in pos. 0 or light barrier covered , the program switches to the next start of a seam without issuing signals M1/M2. 2 = As with setting "1". But with pedal in pos. 0 signals M1/M2 will be issued, and the program switches to the next start of a seam. 3 = As with setting "1". But with pedal -2 signals M1/M2 will be issued, and the program switches to the next start of a seam. Intermediate stop and sewing foot lifting with pedal in pedal -1 is possible. 4 = If the light barrier is covered during the end count for chain suction, the program switches immediately to the next start of a seam. If the end count has been completed and the light barrier remains uncovered, the drive stops. 5 = Tape cutting at the start of the seam with stop		5	0	0	

Parameters	Designation	Unit	Max	Min	Preset	Ind.
019	-Pd	0 = Pedal in pos. -1 blocked in the seam. But with pedal in pos. -2 sewing foot lifting is possible in the seam (function active whenever the light barrier is On) 1 = With pedal in pos. -1 sewing foot lifting is blocked in the seam. 2 = Pedal in pos. -2, thread trimming disabled. (Function only if parameter 009 = 1) 3 = Pedal in pos. -1 and -2 enabled in the seam. 4 = Pedal -1 and -2 locked in the seam (function only when parameter 009 =1) 5 = Start seam end by with pedal -1	5	0	3	
020	kLm	Clamp at the seam end On/Off	1	0	0	
021	ckL	Run-out stitches clamp at the start of the seam	Stitches	254	0	2
022	SPO	0 = Chain suction until the end of count c2 1 = Chain suction at the seam end until pedal in pos. 0 (neutral) 2 = Chain suction until the drive is at standstill and the switch-off start backtack (Parameter 237) has elapsed.	2	0	0	
023	AFL	Automatic sewing foot lifting with pedal forward at the seam end, if light barrier or stitch counting is On. 0 = Automatic foot lifting off 1 = Automatic foot lifting On	1	0	1	
024	FSP	Coupled thread tension release and sewing foot lifting. The function can be activated only with a thread trimmer that depends on the angle. 0 = No coupling 1 = Coupled thread tension release and sewing foot at the seam end with thread trimmer off 2 = Coupled thread tension release and sewing foot in the seam and at the seam end with thread trimmer off 3 = Coupled thread tension release and sewing foot always effective	3	0	0	
025	tFS	Start counting (pa. 157) for thread tension release at the start of the seam 0 = Start counting at the start of the seam 1 = Start counting when the light barrier is covered	1	0	1	
026	APd	Characteristic of the "analog pedal" 0 = Analog function off 1 = 12-level, like previous pedal function 2 = continuously variable 3 = 24-level 4 = 60-level 5 = 48-level 6 = 48 level / standing operation (SOP; foot control 304)i	6	0	4	
027	plu	Area for setting + 1/2 of the analog pedal in percent	80	10	30	
028	epd	0 = Function Off 1 = Pedal 2 release only from Pos. 1	0	1	0	
030	rfl	Bobbin thread monitor 0 = Off 1 = Active with stop 2 = Active without stop 3 = Active with stop and start blockage after thread trimming 4 = As 1, but with display of remaining stitches 5 = As 2, but with display of remaining stitches 6 = As 3, but with display of remaining stitches	6	0	B	
031	cfw	Number of stitches for bobbin thread monitor. (The 3-digit value must be multiplied by 100).	255	0	B	
037	Tu	Monitoring for FF1 signal in sec	60	0	0	0
038	1FH	Coupling with the 2nd thread tension release AFF1 0 = Off 1 = Coupling with FA 2 = Coupling with HP 3 = Coupling with FA and HP	3	0	0	
039	1FL	Coupling with foot lifting with the 2nd thread tension AFF1 0 = Off 1 = Coupling with foot lifting in the seam 2 = Coupling with foot lifting at the seam end 3 = Coupling with foot lifting in the seam and at the seam end	3	0	0	
040	3FB	Mode FlipFlop3 0 = Off 1 = Switched off when the foot is lifted 2 = Switched off during a reverse backtack				

Parameters	Designation	Unit	Max	Min	Preset	Ind.
	3 = Switched off when the foot is lifted or locked.					
041	EZP	Special pedal function Single stitch / Full stitch 0 = Function Off 1 = Single stitch (assuming needle up to needle down). Afterwards alas a complete hand wheel rotation in speed n9) 2 = Full stitch (a complete hand wheel rotation in speed n9) 3 = Speed limitation up to F-042				
042	GrP	Pedal travel forwards for detection of the special pedal function	%	100	0	40
049	KML	Coupling motor running (Kopplung MotorLäuft) signal (F-290=7) =0 OFF =1 Coupling with pedal Mi1 & pedal Mi2 in the seam =2 Coupling with pedal Mi1 & pedal Mi2 outside of the seam =3 Coupling with pedal Mi1 & pedal Mi2 in and outside of the seam				
051	dPd	Time for detection of the special pedal function	ms	2550	0	100
082	DDr	Suck stitches to waste	Stitches	254	0	25
083	tDr	Time sucking waste	ms	5000	0	0
084	Mle	Stitches for motor ECO On	Stitches	254	0	5
085	Mla	Stitches for motor ECO runs down	Stitches	254	0	5
086	vct	Counted forward section in manual ornamental backtack On/Off		1	0	1
087	chr	0 = Manual backtack at speed n13 (Parameter 109) 1..255 = Manual ornamental backtack at speed n9 (Parameter 122)	Stitches	255	0	0
088	kla	Stitches for clamping the seam start (mode 68)	Stitches	20	0	3
090	wAr	Repetition of the start/ multiple backtack		255	0	3
091	wEr	Repetition of the final/multiple backtack		255	0	3
092	Fwr	1 = Backtack repetition On/Off 2 = Repetition of the start backtack with automatic cutting. No end backtack is done.		2	0	0

11.2 Technical level (Code no. 1907)

Parameters	Designation	Unit	Max	Min	Preset	Ind.	
100	SSc	Number of softstart stitches	Stitches	254	0	2	
101	EvA	Switch-on start backtack for the backtacking solenoid in the initial backtack	ms	255	0	43	
102	AvA	Power-off start backtack for the backtacking solenoid in the initial backtack	ms	255	0	4	
103	EvE	Switch-on start backtack for the backtacking solenoid in the final backtack	ms	255	0	43	
104	AvE	Power-off start backtack for the backtacking solenoid in the final backtack	ms	255	0	5	
108	PEr	Stop position of the ornamental backtack 1 = Position 1 leading 2 = Position 2 leading 3 = Position 1 trailing 4 = Position 2 trailing 5 = Position 3 leading 6 = Position 3 trailing		6	1	1	
109	n13	Speed of manual backtack	RPM	9900	200	1500	
110	n1	Positioning speed for threading (mode 66)	RPM	390	70	200	
111	n2	Upper limit setting range of the maximum speed	RPM	9900	n2_	5000	
112	n3	Start backtacking speed	RPM	9900	200	1200	
113	n4	End backtacking speed	RPM	9900	200	1200	
114	n5	Speed after light barrier sensing	RPM	9900	200	1200	
115	n6	Softstart speed	RPM	9900	70	500	
116	n7	Trimming speed	RPM	700	70	200	
117	n10	High lift for walking speed limitation	RPM	9900	400	1000	
118	n12	Automatic speed for stitch counting	RPM	9900	400	3500	
119	nSt	Speed stage graduation 1 = Linear 2 = Slightly progressive 3 = Highly progressive		3	1		
121	n2	Lower limit setting range of the maximum speed	RPM	n2_	200	400	
122	n9	Limited speed n9	RPM	9900	200	2000	
123	n11	Limited speed n11	RPM	9900	200	2500	
125	bot	Speed limitation using ext. potentiometer (minimum value)	RPM	Pa.25	0	200	
126	Pot	Function "speed limitation using external potentiometer" 0 = Function "external potentiometer" Off 7 = Lift-dependent speed limiting with potentiometer (if parameter 911= 912).		7	0	0	
127	AkS	Acoustic signal for V8xx ON/OFFI		1	0	0	
128	ASd	Start start backtack, when command "start" is given by covering the light barrier (see parameter 129)	ms	2000	0	0	
129	ALS	Machine start by covering the light barrier (only in conjunction with parameter 132 = 1) 0 = Function Off 1 = Light barrier covered → pedal forward (>1) → machine run pedal controlled. 2 = Pedal forward (>1) → light barrier covered machine run → pedal controlled. 3 = Light barrier covered → machine run at automatic speed n12 (without pedal) 4 = Pedal forward (>1) → light barrier covered machine run → pedal controlled. 5 = Light barrier covered → machine run at automatic speed n12 (without pedal) Attention! If 129 = 3, the machine starts immediately after covering the light barrier without influence by the pedal! It can be stopped only by uncovering the light barrier or by machine run blockage! If machine run blockage is disabled, the machine starts immediately even if the light barrier is still covered! 6 = The same as 3, run without pedal when covering the light curtain, however start up only when FI is lowered.		3	0	0	
130	LSF	Light barrier filter for knitted fabrics		1	0	0	
131	LSd	0 = Light barrier sensing "covered" 1 = Light barrier sensing uncovered		1	0	1	
132	LSS	0 = Machine start possible with light barrier uncovered or covered. 1 = Machine start blocked with light barrier uncovered if parameter 131 = 1. Machine start blocked with light barrier covered,		1	0	1	

Parameters	Designation	Unit	Max	Min	Preset	Ind.
133	LSE	Thread trimming operation, when completing the seam after light barrier sensing On/Off	1	0	1	
134	SSt	Softstart On/Off	1	0	0	
135	SrS	Ornamental backtack On/Off	1	0	0	
136	FAR	0 = Trimming stitch backward Off 1 = Trimming stitch backward On with single end backtack 2 = Trimming stitch or positioning stitch always backward at the seam end	2	0	0	

Parameters	Designation	Unit	Max	Min	Preset	Ind.
137	hP	High lift for walking foot function activated/deactivated	1	0	0	
139	nIS	Display of machine speed On/Off	1	0	0	
140	dnE	Start backtack of seam end with pedal in pos. -2	ms	2550	0	0
141	SGn	Speed status for the seam with stitch counting 0 = Speed controllable by the pedal up to the set maximum speed (Parameter 111) 1 = Fixed speed (Parameter 118) without influence by the pedal (machine stop by pressing the pedal to the basic position) 2 = Limited speed controllable by the pedal up to the set limit (Parameter 118) 3 = At fixed speed (Parameter 118) can be interrupted by full heelback -2 4 = At fixed speed (Parameter 110) can be interrupted by full heelback -2	4	0	0	
142	SFn	Speed status for the free seam and for the seam with light barrier 0 = Speed controllable by the pedal up to the set maximum speed (Parameter 111) 1 = Fixed speed (Parameter 118) without influence by the pedal (machine stop by pressing the pedal to the basic position) 2 = Limited speed controllable by the pedal up to the set limit (Parameter 118) 3 = At fixed speed (Parameter 118) can be interrupted by full heelback (only for seams with light barrier).	3	0	0	
143	kSA	Stitch counting at the start of the seam (e. g. chain suction) 0 = Speed controllable by the pedal up to the set maximum speed (Parameter 111) 1 = Fixed speed (Parameter 112) without influence by the pedal (machine stop by pressing the pedal to the basic position) 2 = Limited speed controllable by the pedal up to the set limit (Parameter 112) 3 = At fixed speed (Parameter 112), can be suspended or interrupted depending on the setting of parameter 019.	3	0	0	
144	kSE	Stitch counting at the seam end (e. g. chain suction) 0 = Speed controllable by the pedal up to the set maximum speed (Parameter 111). Fixed speed (Parameter 113) without influence by the pedal (machine stop by pressing the pedal to the basic position). 1 = Limited speed controllable by the pedal up to the set limit (Parameter 113) 2 = At fixed speed (Parameter 113), can be suspended or interrupted depending on the setting of parameter 019.	3	0	0	
145	Shv	Speed status for the manual backtack 0 = Speed controllable by the pedal up to the set maximum speed (Parameter 111) 1 = Fixed speed (Parameter 109) without influence by the pedal (machine stop by pressing the pedal to the basic position) 2 = Limited speed controllable by the pedal up to the set limit (Parameter 109)	2	0	0	
150	t8	Stitch correction of the double start backtack (prolongation of the stitch regulator ON period / not effective with ornamental backtack)	ms	500	0	0
151	t9	Stitch correction of the double end backtack (prolongation of the stitch regulator ON period / not effective with ornamental backtack)	ms	500	0	0
152	thP	High Lift Walking Speed Run-Out Time	ms	500	80	150
153	brt	Braking power at machine standstill		50	0	15

Parameters	Designation	Unit	Max	Min	Preset	Ind.
155 LSG	Mode signal run 0 = Signal Off. 1 = Signal run On. 2 = Signal "run" enabled when the speed is >3000 RPM. 3 = Signal with pedal <> 0. 4 = Signal enabled only after motor synchronization (one rotation at positioning speed after power On). 5 = Motor runs Eco with setting F-84 and F-85 6 = Motor runs the same as chain suction at the seam start / end with counter F-084 and F-085 7 = The same as 6, however chain suction at the start of the seam can be interrupted and with switch-off start backtack F-156		7	0	1	
156 t05	Switch-off start backtack for the signal "run" or signal with pedal in pos. 0 (neutral)	ms	2550	0	0	
157 SFS	Stitches until thread tension release Off after light barrier covered at the start of the seam (Only in mode 7)	Stitches	254	0	0	
161 drE	Direction of motor rotation 0 = Clockwise rotation 1 = Counterclockwise rotation		1	0	1	
162 n2A	Start backtack speed whenever the backtack can be interrupted by pedal in pos. 0 (neutral) (Parameter 164)	RPM	9900	200	600	
163 n2E	End backtack speed whenever the backtack can be interrupted by pedal in pos. 0 (neutral) (Parameter 164)	RPM	9900	200	600	
164 StP	Start and end backtack can be interrupted by pedal in pos. 0 (neutral) On/Off		1	0	0	
170 Sr1	- See Section Fehler! Verweisquelle konnte nicht gefunden werden. Setting the reference position (Parameter 170)					
172 Sr3	See Section 6.10 Indication of the setting of the positions					
173 Sr4	See Section 8 Signal test				OFF	
174 Lng	Language selection V860 control panel 1 = English 2 = German	2		1	174	Ln
176 Sr6	Service routine for total operating hours display. The process is as with display example of parameter 177.					
177 Sr7	Service routine for display of hours since the last service. Display example for the operator control panel: Press the E key → Display Sr7= Press the >> key → Display h t Press the E key → Display 0000 Press the >> key → Display h h Press the E key → Display 0000 Press the E key → Display Min Press the E key → Display 00 Press the E key → Display SEc Press the E key → Display 00 Press the E key → Display MS Press the E key → Display 000 Press the E key → Display rES Press the E key again to restart routine, or press the P key twice to return to operational status Display example for the V810 control panel: Press the E key → Display Sr7 [°] Press the >> key → Display hoUr Press the E key → Display 000000 Press the E key → Display Min Press the E key → Display 00 Press the E key → Display SEc Press the E key → Display 00 Press the E key → Display MSEc Press the E key → Display 000 Press the E key → Display rES F2 Press the P key twice → Display e.g. Ab620A Display example for the V820 control panel: Press the E key → Display F-177 Sr7 [°] Press the >> key → Display hoUr 000000					

		Press the E key → Display Min 00				
		Press the E key → Display SEc 00				
		Press the E key → Display MSEc 000				
		Press the E key → Display rES F2				
		Press the P key twice → Display e.g. Ab620A				
179	Sr5	Display of control program number with index and more identification numbers. The data is displayed in sequence by keystroke. Display example for the operator control panel: Press the E key → Display Sr5= Press the >> key → Display e.g. 5034 (Prog. No.) Press the E key → Display e.g. A (Index) Press the E key → Display e.g. 06 (Year) Press the E key → Display e.g. 10 (Month) Press the E key → Display e.g. 24 (Day) Press the E key → Display e.g. 16 (Hour) Press the E key → Display e.g. -- Press the E key → Display e.g. ---- Press the E key again to restart routine, or press the P key twice to return to operational status				
		Display example for the V810 control panel: Press the E key → Display Sr [°] Press the >> key → Display e.g. 5054 Press the E key → Display e.g. 010823 Press the E key → Display e.g. 15 Press the E key → Display e.g. 1F68 Press the P key twice → Display Ab620A Display example for the V820 control panel: Press the E key → Display F-179 Sr5 [°] Press the >> key → Display e.g. PrG 5054 Press the E key → Display e.g. dAt 01082315 Press the E key → Display e.g. Chk 1F68 Press the E key → Display e.g. 132650210015 Press the E key → Display e.g. Skn 01047543 Press the P key twice → Display 4000 Ab620A				
180	rd	Reversing angle	Degrees	359	0	175
181	drd	Switch-on start backtack of reverse motor rotation	ms	990	0	10
182	Frd	Reverse motor rotation On/Off		1	0	0
184	c6	Number of run-out stitches when unlocking the chain	Stitches	254	0	20
185	chP	Minimum number of stitches for high lift for walking	Stitches	254	0	0
190	mEk	Function "unlock the chain" in modes 5, 6 and 7 (Parameter 290) 0 = Unlocking off 1 = Unlocking the chain manually (with pedal in pos. -2 without cutting at the seam end) 2 = Unlocking the chain automatically - By means of light barrier or - pedal in pos.-2 (Parameter 019) without cutting at the seam end 3 = Unlocking the chain automatically - By means of light barrier or - Pedal in pos. -2 (Parameter 019) with cutting and run-out stitches (Parameter 184) at the seam end, then unlocking the chain (only if parameter 290 = 7) 4 = Unlocking only with pedal 2 No unlocking the chain at the seam end by means of light barrier, cutting and run-out stitches.		4	0	1
191	mhE	Seam end for overlock mode through End count c2 or c4 0 = Seam end after count c4 – Tape cutter 1 = Seam end after count c2 – chain suction		1	0	0
192	PLS	Speed of the light barrier compensating stitches 0 = Speed n5 after light barrier sensing 1 = Speed pedal controlled		1	0	0

193	kSL	Enable chain suction signal and thread tension release 0 = Thread tension release and chain suction after the light barrier compensating stitches 1 = Chain suction from light barrier uncovered onwards and thread tension release after the light barrier compensating stitches	1	0	0	
198	Bag	Functions with chainstitch machines e. g. bag sewing machine (Parameter 290 = 37) 0 = Function "thread trimming" or "hot thread chain cutting" and sewing foot lift using the pedal. 1 = Function "thread trimming" or "hot thread chain cutting" using the knee switch, and sewing foot lift using the pedal. 2 = Function "thread trimming" or "hot thread chain cutting" using the pedal and sewing foot lift using the knee switch.	2	0	0	
199	FSn	Thread tension release at the seam end On/Off. 0 = Thread tension release Off at the seam end for pedal in pos. 0. 1 = Thread tension release On at the seam end for pedal in pos. 0. 2 = Thread tension release at the seam end and after power on and pedal in position 0 On.	2	0	0	

11.3 Supplier level (Code No. 3112)

Parameters	Designation	Unit	Max	Min	Preset	Ind.	
200	t1	Start backtack until speed release after start backtack	ms	500	0	100	
201	t2	Sewing foot switch-on start backtack after thread wiper with half heelback	ms	2550	20	80	
202	t3	Start start backtack after disabling the sewing foot lifting signal	ms	500	0	50	
203	t4	Time of full power of sewing foot lifting	ms	600	0	500	
204	t5	Holding power for sewing foot lifting 1...100% 1% → low holding power 100% → high holding power	%	Pa.254	1	40	
205	t6	Thread wiper time	ms	2550	0	120	
206	t7	Start backtack from end of thread wiper until sewing foot lifting On	ms	800	0	40	
207	br1	Braking effect when varying the preset value ≤ 4 stages (indicated values only with transmission ratio 1:1)		55	1	15	
208	br2	Braking effect when varying the preset value ≥ 5 stages (indicated values only with transmission ratio 1:1)		55	1	20	
209	dFw	Thread wiper switch-on start backtack	ms	2550	0	0	
210	tSr	Stop time for switching the stitch regulator in the ornamental backtack	ms	500	0	140	
211	tFL	Sewing foot lifting switch-on start backtack with thread wiper off	ms	500	0	60	
212	t10	Time of full power of backtacking or thread trimmer forward	ms	600	0	500	
213	t11	Holding power for backtacking or thread trimmer backward 1...100% 1% → low holding power 100% → high holding power	%	Pa.255	1	40	
215	Zrv	0 = Last counted forward segment in start backtack OFF 1 = Last counted forward segment in start backtack On		1	0	0	
217	Sr	Number of operating hours before service in steps of 10 (operating hours recording enabled if set at "0").	Std	99900 ***)	00000	00000	
218	SkL	Select custom machines 0 = No custom machine 1 = Model 204 2 = Big Bag		2	0	0	
219	br3	Braking ramp for $n < 350 \text{ min}^{-1}/\text{ms}$ when drive stopped		55	1	4	
220	ALF	Accelerating power of the drive (indicated values only with transmission ratio 1:1)		55	1	35	
221	dGn	Speed gate 1	RPM	990	50	100	
222	tGn	Speed gate damping period	ms	990	0	20	
225	br4	Setting the braking curve for the light barrier and machine run blockage (values only with transmission ratio 1:1)		55	1	20	
229	dP2	Start backtack of heelback (-2)	ms	2000	0	0	
232	USS	Overlock with fast scissors On/Off		1	0	0	
233	c	Thread tension release switch-on start backtack	Stitches	254	0	0	
234	pdo	Restart after machine run blockage via pedal 0 position		1	0	1	B
236	FLP	0 = FI always permitted 1 = FI only permitted in position 2 2 = FI after cutting stored pedal plus ½ lifts storing, pedal minus 1 switches stored FI on. 3 = Storage for standing actuation FBxxx 4 = FI generally deactivated 5 = Stored foot lifting at the seam end can be deactivated with pedal plus ½ and pedal minus 1.		5	0	0	B
237	tkS	Switch-off start backtack for chain suction at the seam end, if parameter 022 = 2.	ms	2550	0	0	
238	EnP	Software debouncing for all inputs: 0 = No debouncing 1 = Debouncing		1	0	1	
239	FEL	Selection of the input function on socket B18/8 0 = Light barrier function, if 009 = 1 All other functions as with parameter 240.		112	0	0	

***) The 4-digit value displayed must be multiplied by 10.

Supplier level (Code No. 3112)

Parameters	Designation	Unit	Max	Min	Preset	Ind.
240 in1	Selection of the input functions on socket ST2/7 for input 1 0 = No function 1 = Needle up/down 2 = Needle up 3 = Single stitch (basting stitch) 4 = Full stitch 5 = Needle to position 2 6 = Machine run blockage effective with open contact 7 = Machine run blockage effective with closed contact 8 = Machine run blockage unpositioned effective with open contact 9 = Machine run blockage unpositioned effective with closed contact 10 = Automatic speed n12 without pedal (N.O. contact) 11 = Limited speed n12 pedal controlled 12 = Sewing foot lifting with pedal in position 0 (neutral) 13 = High lift for walking foot with speed limitation n10 (operational mode not stored) 14 = "High lift walking foot" with speed limiting n10. Set parameter 137 to 1 15 = tape cutter/fast scissors: Function only in chainstitch and overlock mode 16 = Intermediate backtack / intermediate stitch condensing 17 = Stitch regulator suppression / recall 18 = Unlocking the chain: Can be activated by pressing the key , but will be executed only at the seam end 23 = No function 24 = Needle to position 2 (see instruction manual) 27 = Unlocking the chain: Function is performed upon pressing the key 28 = External light barrier (according to setting of parameter 131) 30 = High lift for walking foot, if sewing foot is On 31 = Function "speed limitation bit0" (speed n11) 32 = Function "speed limitation bit1" (speed n10) (bit0 + bit1 = speed n9) 33 = Speed n9 pedal controlled 34 = Automatic speed n9 can be suspended by pressing the pedal to pos. 0 (neutral) 37 = Speed n12 pedal controlled (break contact) 38 = Automatic speed n12 without pedal (break contact [N.C.]) 41 = Tape cutting only at machine standstill 42 = Enable hot thread chain cutting or sewing foot lifting. Function only effective in mode 37 43 - 85 = No function 91 = Threading mode 66 101 = AFF1 ex.2. Thread tension release 102 = AFF2 ex. switch stitch length 103 = AFF3 example of an edge guide 104 = Manual lock automatic 109 = Part lift mode 66 110 = Machine run blockage in Pos. 2 at the seam end open 111 = Machine run blockage in Pos. 2 at the seam end close 112 = Foot lifting FlipFlop 113 – 117 No function 118 = Flipflop for running in nmax 119-123= No function 124 = Disable Strobel backtack 125-127 = No function 128 = Reset stitch counter 129 = Reset stitch counter for service 130 = Pedal -2 per external key 131-145= No function		145	0	0	
241 in2	Selection of input function on socket ST2/11 for input 2 0 = No function All other functions of the keys as with parameter 240		145	0	0	
242 in3	Selection of input function on socket ST2/6 for input 3 0 = No function All other functions of the keys as with parameter 240		145	0	0	

Parameters	Designation	Unit	Max	Min	Preset	Ind.
243	in4 Selection of input function on socket ST2/8 for input 4 0 = No function All other functions of the keys as with parameter 240		145	0	0	
244	in5 Selection of input function on socket ST2/5 for input 5 0 = No function All other functions of the keys as with parameter 240		145	0	0	
245	in6 Selection of input function on socket ST2/12 for input 6 0 = No function All other functions of the keys as with parameter 240		145	0	0	
246	in7 Selection of input function on socket ST2/9 for input 7 0 = No function All other functions of the keys as with parameter 240		145	0	0	
250	iFA Thread trimmer activation angle	Degrees	359	0	180	
251	FSA Switch-off start backtack of thread tension release	ms	990	0	50	
252	FSE Switch-on start backtack angle of thread tension release	Degrees	359	0	0	
253	tFA Stopping time for thread trimming	ms	500	0	70	
254	EF- Upper limit (Pa.204) clocking the sewing foot lifting switch on period (ED) 1...100 %	%	100	1	100	
255	Ev- Upper limit (Pa.213) clocking the sewing foot on period (ED) 1...100 %1...100	%	100	1	100	
259	FAE Activation start backtack angle of the thread trimmer	Degrees	359	0	0	
263	ihP 0 = Signal "high lift for walking foot", when key is closed. 1 = Signal "high lift for walking foot", when key is open. (Function only if parameter 137 = 1)		1	0	0	
267	Abc Overlock mode: Interrupt the start count And seam end initiation by light barrier uncovered		1	0	0	
268	SEL Speed limitation via "select". (F290=55 & F290=74)		1	0	0	
269	PSv Positioning shift	Incr.	100	0	10	
270	PGm Mode for position sensor 0 = No external sensor. Positions are created via the sensor integrated in the motor. 5 = No position sensor available. The drive stops unpositioned. The thread trimmer function is suppressed with this setting. 6 = With external sensor (e.g. IPG, HSM...).		6	0	0	
272	trr Transmission ratio between motor shaft and machine shaft (calculation formula see instruction manual!) The transmission ratio should be determined and indicated as precisely as possible!		40000	150	1000	
280	kd1 Start backtack time output M1	ms	5000	0	0	
281	kt1 ON period output M1	ms	5000	0	100	
282	kd2 Start backtack time output M2	ms	5000	0	100	
283	kt2 ON period output M2	ms	5000	0	100	
284	kd3 Start backtack time output M3	ms	5000	0	200	
285	kt3 ON period output M3	ms	5000	0	100	
286	kd4 Start backtack time output M4	ms	5000	0	300	
287	kt4 ON period output M4	ms	5000	0	100	
288	kdF Start backtack time until sewing foot On	ms	5000	0	380	

290	FAm	<p>Selection of machine specific mode</p> <p>0 = Lockstitch: (FA1, FA2, FA3, FA1+FA2): e.g. BrotherDürkopp Adler, Mitsubishi, Pfaff, Toyota »Slide-in strips for V810/V820 =1/1«</p> <p>1 = No Function</p> <p>2 = Lockstitch: e.g. Singer (212 UTT) »Slide-in strips for V810/V820 =1/1«</p> <p>3 = Lock stitch (medium duty, general): e.g. Dürkopp Adler, Juki, Pfaff, Sunstar, Golden Wheel »Slide-in strips for V810/V820 =1/1«</p> <p>4 = Chainstitch Union Special 34000, 36200 »Slide-in strips for V810/V820 =1/1«</p> <p>5 = Chainstitch general: M1, M2, M3 and M4 parallel sequence »Slide-in strips for V810/V820 =5/3«</p> <p>6 = Chainstitch with tape cutter and Fast scissors and M1 / M2 at the seam end »Slide-in strips for V810/V820 =5/3«</p> <p>7 = Overlook »Slide-in strips for V810/V820 =7/5«</p> <p>8 = Backlatch: Pegasus »Slide-in strips for V810/V820 =7/5«</p> <p>9 = Backlatch: Yamato »Slide-in strips for V810/V820 =7/5«</p> <p>10 = Union Special Lockstitch (63900AMZ) »Slide-in strips for V810/V820 =1/1«</p> <p>11-12= No function</p> <p>13= Lockstitch: Pfaff (1425, 1525) »Slide-in strips for V810/V820 = 1/1«</p> <p>14 = Lockstitch: Juki (5550-6, 5550-7) »Slide-in strips for V810/V820 =1/1«</p> <p>15= Reserved</p> <p>16= No function</p> <p>17 = Chainstitch: Pegasus Stitchlock »Slide-in strips for V810/V820 =5/3«</p> <p>18-24= No function</p> <p>25 = Lockstitch: Juki (LU2210/LU2260) »Slide-in strips for V810/V820 =1/1«</p> <p>26-36= No function</p> <p>37 = Union Special Bag Machine »Slide-in strips for V810/V820 =1/1«</p> <p>38 = Lockstitch: HonYu Klasse HY-4410 »Slide-in strips for V810/V820 =1/1«</p> <p>39-46=No function</p> <p>47= Hand-stitch machine: Guta Activation necessary! »Slide-in strips for V810/V820 = 4/4«</p> <p>48-51= No function</p> <p>52= Lockstitch: Golden Wheel (8671) »Slide-in strips for V810/V820 = 5/5«</p> <p>53 = Lockstitch: Juki (LU2810-6) »Slide-in strips for V810/V820 =2/2«</p> <p>54 = No function</p> <p>55 = Chainstitch with UTQ: Yamato »Slide-in strips for V810/V820 =13/17«</p> <p>56 = Strobel replacement St220 as mode 5 with end backtack »Slide-in strips for V810/V820 =5/2«</p> <p>57 = Lock stitch:Typical Kl. TW1-591 snaplock »Slide-in strips for V810/V820 =5/2«</p> <p>58 = Lockstitch: Juki PLC 2760 »Slide-in strips for V810/V820 =5/2«</p> <p>59 = Lockstitch: DA class 768 »Slide-in strips for V810/V820 =5/2«</p> <p>60 = Lockstitch: Typical class 1245 »Slide-in strips for V810/V820 =5/2«</p> <p>61 = Lockstitch: Kaiser class 570/590 »Slide-in strips for V810/V820 =5/2«</p> <p>62 = Lockstitch: Typical/Mauser Klasse 335 »Slide-in strips for V810/V820 =5/2«</p>	79	0	0	
-----	-----	---	----	---	---	--

		<p>63 = Lockstitch: Juki DNU 1541-7 »Slide-in strips for V810/V820 =5/2«</p> <p>64 = No function</p> <p>65 = Chainstitch: Sagitta »Slide-in strips for V810/V820 =5/2«</p> <p>66 = Chainstitch: Strobel VTD 410EV »Slide-in strips for V810/V820 =5/2«</p> <p>67 = Chainstitch: Hengtai MP500»Slide-in strips for V810/V820 =5/2«</p> <p>68 = Lockstitch: Typical/Mauser Klasse 333 »Slide-in strips for V810/820 =5/2«</p> <p>69 = Lockstitch: Juki class 1760 »Slide-in strips for V810/820 =5/2«</p> <p>70= Reserved</p> <p>71= No function</p> <p>72= CL205/CL204 »Slide-in strips for V810/820 =5/5«</p> <p>73= Reserved</p> <p>74= Chainstitch: Yamato VG »Slide-in strips for V810/820 =5/5«</p> <p>75= SHDA CL160-30 »Slide-in strips for V810/820 =5/5«</p> <p>76= Reserved</p> <p>77= Reserved</p> <p>78=Golden Wheel CSR88914 »Slide-in strips for V810/820 =5/5«</p> <p>79 Gute GT8700C »Slide-in strips for V810/820 =5/5«</p> <p>Other modes are selectable, however have the same functions as mode 0.</p>					
291	810	Select slide-in strip number for the V810 control panel (illustration see instruction manual for part V810/V820. At setting 0 , keys 1...4 are disabled.		13	0	1	
292	820	Select slide-in strip number for the V820 control panel (illustration see instruction manual for part V810/V820. At setting 0 , keys 1...0 are disabled.		17	0	1	
293	tF1	<p>Selection of the input function using key (A) "F1" on the V810/V820 control panel</p> <p>0 = Key F1 is disabled</p> <p>1 = Needle up/down</p> <p>2 = Needle up</p> <p>3 = Single stitch (basting stitch)</p> <p>4 = Full stitch</p> <p>5 = Needle to position 2</p> <p>6...12 = No function</p> <p>13 = High lift for walking foot with speed limitation n10 (operational mode not stored)</p> <p>14 = High lift for walking foot with speed limitation n10 (operational mode stored)</p> <p>15 = Tape cutter / fast scissors (in chainstitch and overlock mode)</p> <p>16 = Intermediate backtack/intermediate stitch condensing</p> <p>17 = Stitch regulator suppression / recall</p> <p>18 = No function</p> <p>19 = Bobbin thread monitor</p> <p>20..Rest = No function</p>		100	0	17	

Parameters	Designation	Unit	Max	Min	Preset	Ind.	
294	tF2	Selection of the input function using key (B) "F2" on the V810/V820 control panel Functions of the key as with parameter 293, but at setting 0 key F2 is disabled.		100	0	1	
297	mSO	Custom signal 0 = Function Off 1 = Signal is switched on whenever the light barrier is uncovered (Pa.131 =1) or covered (Pa 131 =0) 2 = Signal is switched on whenever the light barrier is covered (Pa.131 =1) or uncovered (Pa 131 =0) 3 = Signal switches on from the light barrier to the seam end. 4 = Signal M11 switches on like with setting 3. However, the signal M5 (machine running) is switched off during output M11. When signal M11 is issued, signal M6 (machine at standstill) is also immediately issued.		3	0	0	
298	nSo	Backtack synchronization On/Off	1	0	0		
299	nrS	Stitch locks speed	RPM	3000	150	400	
328	ob	Changing function keys on the control panel 0 = All keys are locked 1 = All keys are released, key E + start backtack, key + end backtack (except mode 7) 2 = All keys are released, button E affects chain suction, button + impacts tape cutter (only in mode 7) 3 = Button E and button + no function 4 = 4 = Button E, + and – no function 5 = Button E affects soft start, button + impacts tape cutter and wiper 6 = Button E affects soft start, button + impacts tape cutter seat start /end		6	0	1	
340	1L	Lower switching threshold of input IN1	%	100	0	30	
341	1L	Upper switching threshold of input IN1	%	100	0	80	
342	2L	Lower switching threshold of input IN2	%	100	0	30	
343	2h	Upper switching threshold of input IN2	%	100	0	80	
344	3L	Lower switching threshold of input IN3	%	100	0	30	
345	3h	Upper switching threshold of input IN3	%	100	0	80	
346	4L	Lower switching threshold of input IN4	%	100	0	30	
347	4h	Upper switching threshold of input IN4	%	100	0	80	
348	5L	Lower switching threshold of input IN5	%	100	0	30	
349	5h	Upper switching threshold of input IN5	%	100	0	80	
350	6L	Lower switching threshold of input IN6	%	100	0	30	
351	6h	Upper switching threshold of input IN6	%	100	0	80	
352	7L	Lower switching threshold of input IN7	%	100	0	30	
353	7h	Upper switching threshold of input IN7	%	100	0	80	
360	11L	Lower switching threshold of input LSM	%	100	0	50	
361	11h	Upper switching threshold of input LSM	%	100	0	70	
362	15V	Switch +5V/+15V on B18 0 = +5V 1 = +15V ATTENTION! When switching to +15 V, IPG and HSM001 can no longer connected to socket B18!		1	0	0	
363	Evr	Ratchet mech. Interlock on /off (F-290 = 58)	1	0	0		B
364	EWi	Ratcheting bracket mech. Interlock (F290 =58)	Degrees	100	0	10	B
365	K4S	Switching Strobel class (F-290 =56) 0 = Standard Strobel machines 1 = Class 45 2 = VEB100-7 band cutter fixture		2	0	0	B
369	FSL	Target setpoint via input PedalC with frequency (AB600A) 0 = AUS 1 = ON / PedalD =Enable 2 = ON / input function 54 = enable		2	0	0	369
370	n2	Direct input of maximum speed	RPM	F-111	F-121	Display	
374	nrd	Reset speed	rpm	390	70	100	B
377	tFl	Time monitoring foot lifting	sec	250	0	0	B
395	Sti	Stitch lock on /off (F-290 = 17)	1	0	0	B	395
		Designation	Unit	Max	Min	Preset	Ind.

Parameters						
396	FSL	Target setpoint via input PedalC with frequency 0 = OFF 1 = ON / PedalD = Enable 2 = ON / input function 54 = Enable	2	0	0	0
401	EEP	Immediate storage of all changed data - Input code number 3112 after power On - Press the E key - -Input parameter 401 - Press the E key - Set display from 0 to 1 - Press the E or P key - All data are stored	1	0	0	
451	P1E	- Start position 1 "Needle lowest position" See Section Fehler! Verweisquelle konnte nicht gefunden werden . Setting the Positions (Parameter 270 = 0 or 6)	359	0		
452	P1A	- End position 1 "Needle lowest position" See Section Fehler! Verweisquelle konnte nicht gefunden werden . Setting the Positions (Parameter 270 = 0 or 6)	359	0		
453	P2E	- Start position 2 thread lever up" / "Needle rod OT" See Section Fehler! Verweisquelle konnte nicht gefunden werden . Setting the Positions (Parameter 270 = 0 or 6)	359	0		
454	P2A	- End position 2 thread lever up" / "Needle rod OT" See Section Fehler! Verweisquelle konnte nicht gefunden werden . Setting the Positions (Parameter 270 = 0 or 6)	359	0		
467	MOT	Selection of motor 1 = Efka DC1500 (512) 2 = Efka DC1550 (512) 3 = Efka DC1200 (512) 4 = Efka DC1250 (512) 5 = QE3760 (256) (Quick Rotan) 6 = QE5540 (256) (Quick Rotan) 7 = Reserved for machine manufacturers 8 = Reserved for machine manufacturers 9 = Efka DC1210 10 =Efka DC1230 11 =Reserved for machine manufacturers 12 =Reserved for machine manufacturers 13 =Reserved for machine manufacturers 14 =Efka DC1280 15 =Reserved for machine manufacturers 16 =Reserved for machine manufacturers 17 =Reserved for machine manufacturers 18 =Reserved for machine manufacturers 19 =Reserved for machine manufacturers 20 =Reserved for machine manufacturers 21 =Reserved for machine manufacturers	21	1	1	
500	Sir	Recall of Fast Installation Routine (SIR) (see chapter "Fast Installation Routine (SIR)"				
510		Transfer parameter settings from control to Memory Stick				
511		Transfer parameter settings from Memory Stick to control				
512		Compare control and Memory Stick parameter settings				
513		Delete parameter setting file from Memory Stick				
527		Transfer control software from Memory Stick to control				
529		Delete control software file from Memory Stick				

Parameters	Designation	Unit	Max	Min	Preset	Ind.
550 in12	Selection of input function on socket B22/3 for input 12 0 = No function All other functions of the keys as with parameter 240		42	0	0	
551 in13	Selection of input function on socket B22/4 for input 13 0 = No function All other functions of the keys as with parameter 240		42	0	0	
552 12L	Lower switching threshold of input IN12	%	100	0	30	
553 12h	Upper switching threshold of input IN12	%	100	0	80	
554 13L	Lower switching threshold of input IN13	%	100	0	30	
555 13h	Upper switching threshold of input IN13	%	100	0	80	
599 LrP	Last pilgrim backtack in positioning speed (n1) On/Off	1	0	1		
808 M4	Upper limit cycle M4 (2. Thread tension release)	%	100	0	100	
820 FF1	FlipFlop1 On/Off		1	0		
821 FF2	FlipFlop2 On/Off		1	0		
822 FF3	FlipFlop3 On/Off		1	0		
823 F1R	FlipFlop1 Reset at thread end On/ Off		1	0		
824 F2R	FlipFlop2 Reset at thread end On/Off		1	0		
825 F3R	FlipFlop3 Reset at thread end On/Off		1	0		
828 cPL	Counter until puller lowers		255	0		
829 MPL	0 = No function 1 = Always ventilate puller at the thread end		1	0		
830 FF1	Selecting the output for flip-flop function AFF1 0 = No output selected 1 = M1 2 = M2 3 = M3 4 = M4 5 = M5 6 = M6 7 = M7 8 = M8 9 = M9 10 = M10 11 = M11	11	0	0		
831 FF2	Selecting the output for flip-flop function AFF2 0 = No output selected 1 = M1 2 = M2 3 = M3 4 = M4 5 = M5 6 = M6 7 = M7 8 = M8 9 = M9 10 = M10 11 = M11	11	0	0		
832 FF3	Selecting the output for flip-flop function AFF3 0 = No output selected 1 = M1 2 = M2 3 = M3 4 = M4 5 = M5 6 = M6 7 = M7 8 = M8 9 = M9 10 = M10 11 = M11	11	0	0		
833 epd	0 = Function Off 1 = Pedal 2 release only from Pos. 1	0	1	0		

902	APt	Service routine to teach the analog pedal. Pedal forwards for standing operation				902	A
905	u86	User-defined function strips for V860 0 = Off (selection of function strip using F-292) 1 = User-defined function strips 1 2 = User-defined function strips 2 3 = User-defined function strips 3 4 = User-defined function strips 4 ▪ User-defined function strips 5	5	0	0	905	u
911		High lift for walking foot - measurement value of potentiometer for minimum lift		255	0	0	
912		High lift for walking foot - measurement value of potentiometer for maximum lift		255	0	0	
939	EnF	Storage for threading function F-290 =66		1	0	0	C
944	t20	Full engagement time for indexed M4		ms	600	0	
945	t21	Cycle M4		%	100	0	

12 Error Displays

On the control	Signification
General Information	
A1	Pedal not in neutral position when turning the machine on
A2	Machine run blockage
A3	Reference position is not set
A6	Light barrier monitoring
A7	Bobbin thread monitor
A9	No thread trimming mode available in parameter 290
A10	Security code missing
A11	High lift foot for walking - measurement of the potis not permitted
A12	The maximum speed configured cannot be reached at this transmission ratio
A16	Error in preset parameter structure.
A17	Error of serial EE PROM
A500	Max. number of files (99) on Memory Stick exceeded
A501	File not found on Memory Stick
A503	Data on Memory Stick and in the control is not equal
A504	Checksum error in file
A511	Error reading/writing file
A512	Error reading/writing file
Operating hours counter	
C1	Operating hours counter has reached or exceeded the service time
C2	Fatal exception error
C3	Program error
C4	C4-001 10h test runs have elapsed, release missing
USB error	
D1	USB Info
Programming Functions and Values (Parameters)	
Returns to 0000 or to last parameter number	Wrong code or parameter number input

Serious Condition	
E1	The external pulse encoder e.g. IPG... is defective or not connected
E2	Line voltage too low, or time between power Off and power On too short
E3	Machine blocked or does not reach the desired speed
E4	Control disturbed by deficient grounding or loose contact
E5	Motor end level over-temperature
E7	24 V power supply unit overload
E8	Too much data for the EEPROM or flash memory
E9	EEPROM or flash memory defective.
E10	End phase transistor short circuit(Output FL, VR, M1, M2, M3, oder M4)
E11	Thermal overload of output stage transistor
E12	Short-circuit on output M5
E13	Thread trimmer does not reach the end position
E14	Power voltage too high: The power voltage is greater than 290 V eff. (The DC motor cannot be started; if running, the motor is stopped without positioning. The motor is passively braked (runs down)!
E15	Internal communications error with intermediate circuit
E16	Power voltage too low: The power feed voltage was less than 120 V eff. (The DC motor cannot be started, and the 24 V is turned off.)
E17	Charging PTC too warm. The intermediate circuit could not be charged to the voltage needed. Possible cause: Switching the controller on/off to many times within a short time. Correction: Turn off controller and allow it to cool. (The duration of the cooling off phase depends on the ambient conditions and can take several minutes).
E18	Intermediate circuit voltage greater than 450 V, braking resistance possibly failed
E19	No motor connected, inverter defective, motor phase failed
E20	Speed too high
E21	Error in the 5 V power supply
E22	EB401: Analog value outside the range
E23	V860: Error during communication
E24	Customer null point sensor not detected
E25	IGM/HSM not detected

Programming and Data Transfer	
F1	Parameter unavailable; wrong code number
F7	RS232 Time out
F8	RS232, error in data transfer, NAK received

Hardware Disturbance	
H1	Commutation transmitter cord or frequency converter disturbed
H2	Processor disturbed

Status messages	
WAIT	Cause: No control software loaded. Solution 1: Software must be loaded with IF232 cable.
PROG	Cause: Controls updates the intermediate circuit processor. If no software update can be executed, this could also be an error of processor communication. Then the message appears every time it is switched on. Solution 1: Software must be loaded with IF232 cable. Solution 2: The controls must be sent in for repair.

For your notes:

For your notes:

For your notes:

For your notes:

For your notes:



FRANKL & KIRCHNER GMBH & CO KG
SCHEFFELSTRASSE 73 – 68723 SCHWETZINGEN
TEL.: +49-6202-2020 – FAX: +49-6202-202115
E-Mail: info@efka.net – www.efka.net



OF AMERICA INC.
3715 NORTHCREST ROAD – SUITE 10 – ATLANTA – GEORGIA 30340
PHONE: +1-770-457 7006 – FAX: +1-770-458 3899 – email: efkaus@bellsouth.net



EFKA SINGAPORE PTE. LTD.
67, AYER RAJAH CRESCENT 05-03 – SINGAPORE 139950
PHONE: +65-67772459 – FAX: +65-67771048 – email: efkaems@efka.net