

**Efka**<sup>®</sup>

motion by innovation



Expertise in  
Drive Technology  
and Automation



Energy efficient  
RoHS compliant  
ECO-friendly  
easy to use - simply good

WWW.EFKA.NET

**AB610A**  
**AB611A**

**Efka**<sup>®</sup>

Frankl & Kirchner GmbH & Co KG  
Antriebs- und Steuerungstechnik  
Drives and Control Systems

# AB610A / AB611A

- Useful for light (DC1500) and heavy-duty (DC1550) sewing applications
- Digital programming directly on the control box
- Programmable maximum rotational speed, acceleration and braking curves
- Operating hours counter
- Machine operating time monitoring with optical indicator when service required

- Flash technology, no Eprom
- Connection for USB memory stick
- Universal mounting above or below the tableboard (undertable mounting set as special accessories)
- Operates with V belt or timing belt (different transmission ratios possible)
- Pedal actuation using EB401 analog actuator

## AB610A

- The ideal positioning drive for simple sewing machines
- Programmable for unpositioned stop as replacement for lever stop motors
- Programmable for two stop positions and soft start function
- Up to 80% energy savings in comparison with clutch motors

## AB611A

- Universally usable for sewing machines with foot lift and thread trim:

**Lockstitch** - Pfaff, Dürkopp Adler, Brother, Juki, Singer, and other brands

**Lockstitch (medium to heavier duty)** - Dürkopp Adler, Pfaff, Juki, Brother, and other brands

**Chainstitch** - All brands

**Overlock** - All brands

**Backlatch** - Pegasus, Yamato

*Adapter cords for various sewing machine brands are available*

- Programmable light barrier functions
- 6 short-circuit proof signal outputs with overload protection
- 7 individually programmable switch inputs
- Separate knee switch connection for KN19

### Direct Mounting

### Undertable Mounting



- Direct mounting kits available for Pegasus EX/EXT, W500/W600, W1500, W2600, M700

Standard Accessory



EB401

External actuator

Special Accessory



HSM001

Position sensor

Special Accessory



IPC001

Pulse encoder

Special Accessory



LSM002

Light barrier module

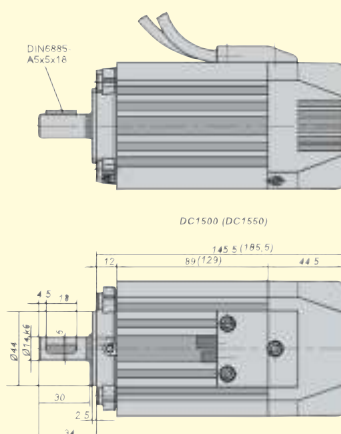

DC1500 (DC1550)

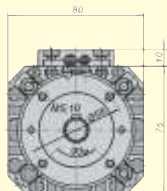

Weight of motor:  
DC1500 - 2.125 kg  
DC1550 - 3.120 kg

KL2312

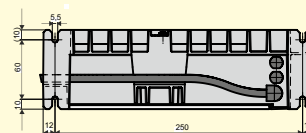
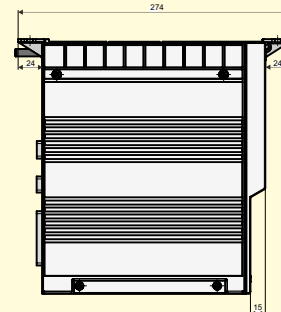
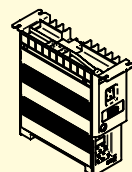

Weight of control:  
2.46 kg

KL2589

**Efka**

FRANKL & KIRCHNER GMBH & CO. KG  
SCHEFFELSTRASSE 73 • 68723 SCHWETZINGEN  
Tel.: 06202 2020 • Fax: 06202 202115  
E-Mail: [info@efka.net](mailto:info@efka.net) • [www.efka.net](http://www.efka.net)

**Efka**

OF AMERICA INC.  
3715 NORTHCREST ROAD SUITE 10  
ATLANTA GEORGIA 30340  
Phone: +1 (770) 457-7006 Fax: +1 (770) 458-3899  
E-mail: [efkausa@bellsouth.net](mailto:efkausa@bellsouth.net)

**Efka**

ELECTRONIC MOTORS SINGAPORE PTE. LTD.  
67, AYER RAJAH CRESCENT 05-03  
SINGAPORE 139950  
Phone: +65 67772459 Fax: +65 67771048  
E-mail: [efkaems@efka.net](mailto:efkaems@efka.net)